

AKS DRAWING FILE: 5617 DRIVEWAY PROFILE.DWG | LAYOUT: PRELIMINARY DRIVEWAY PLAN & PROFILE

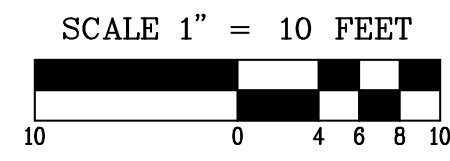
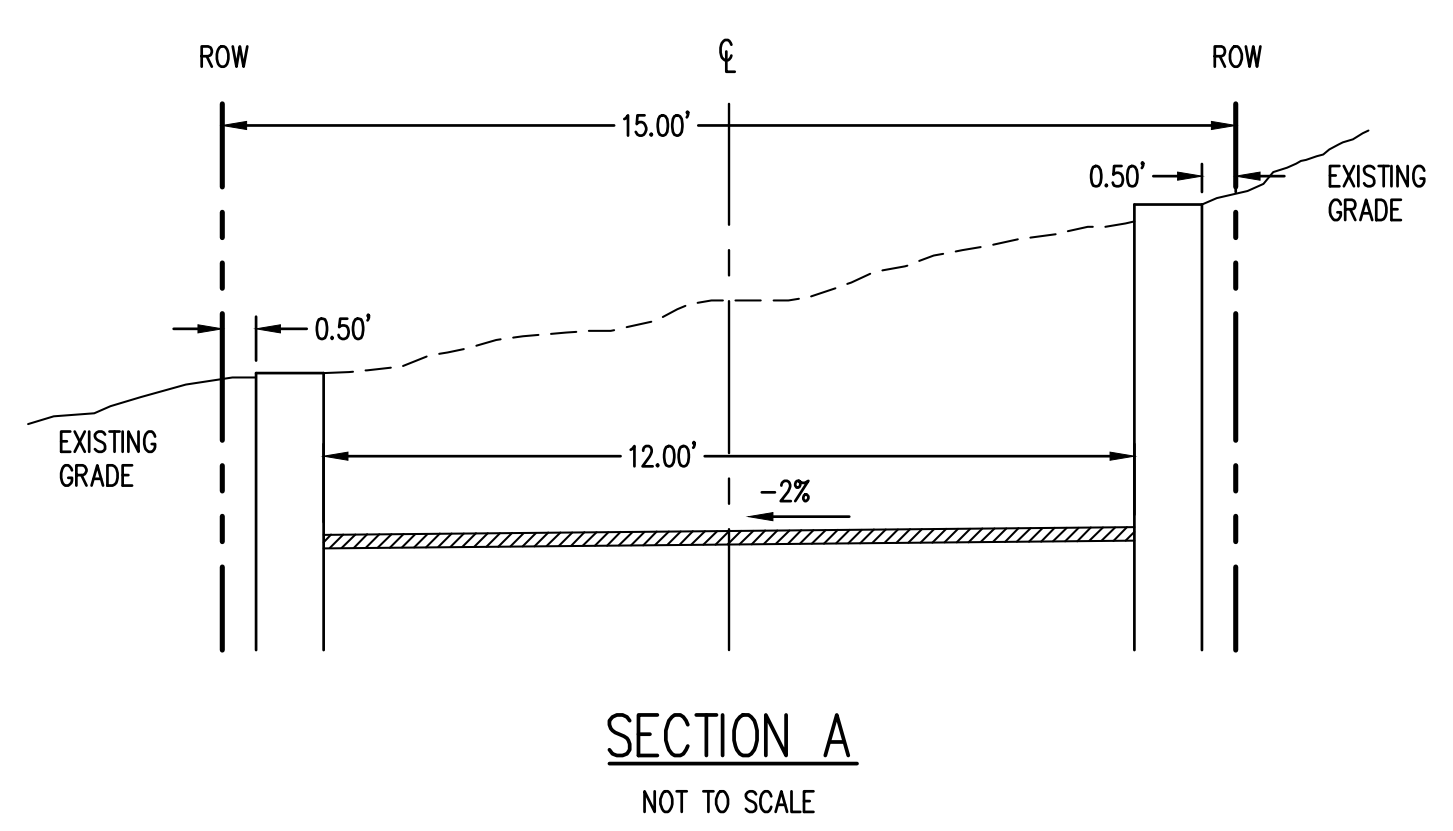
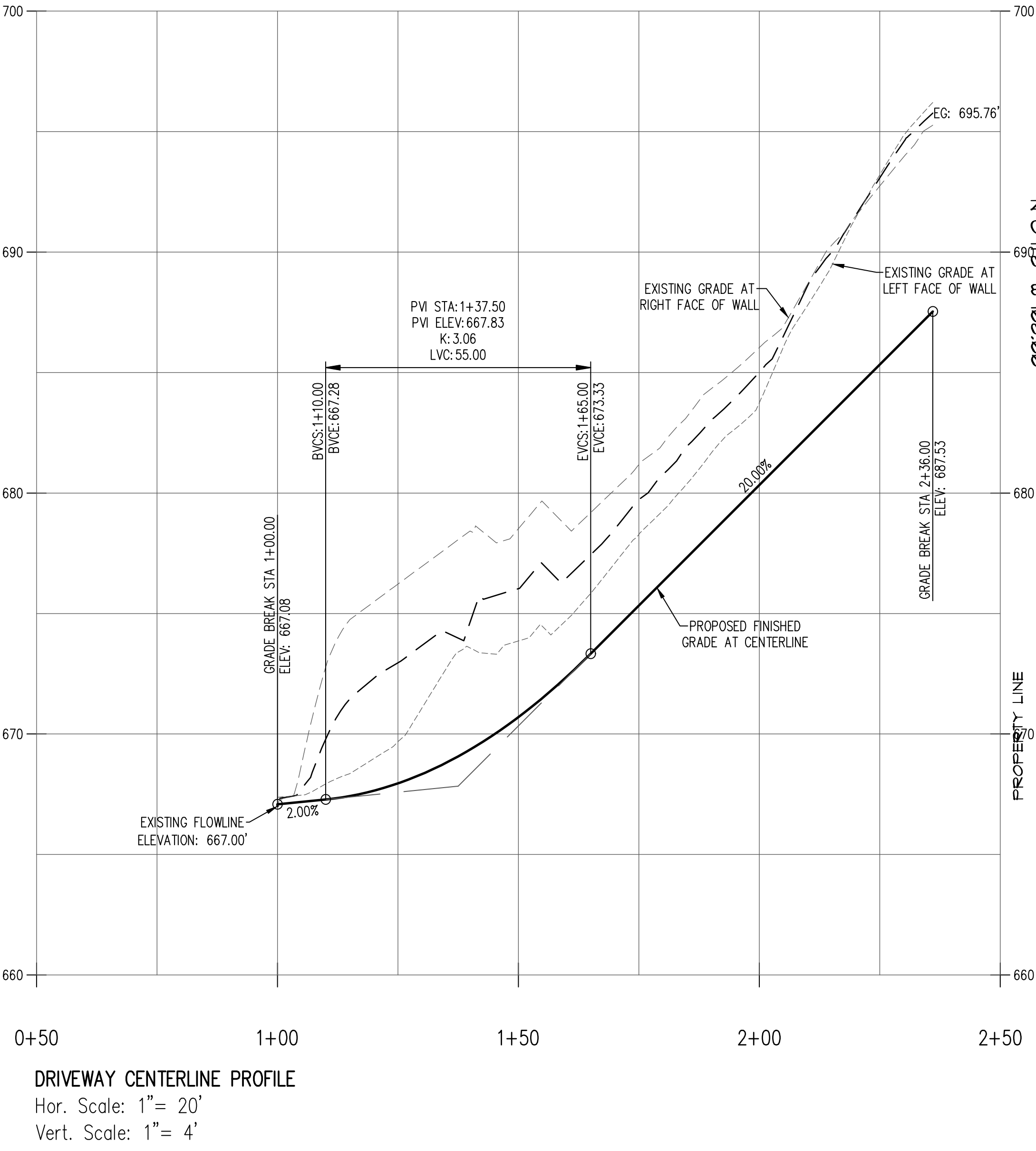
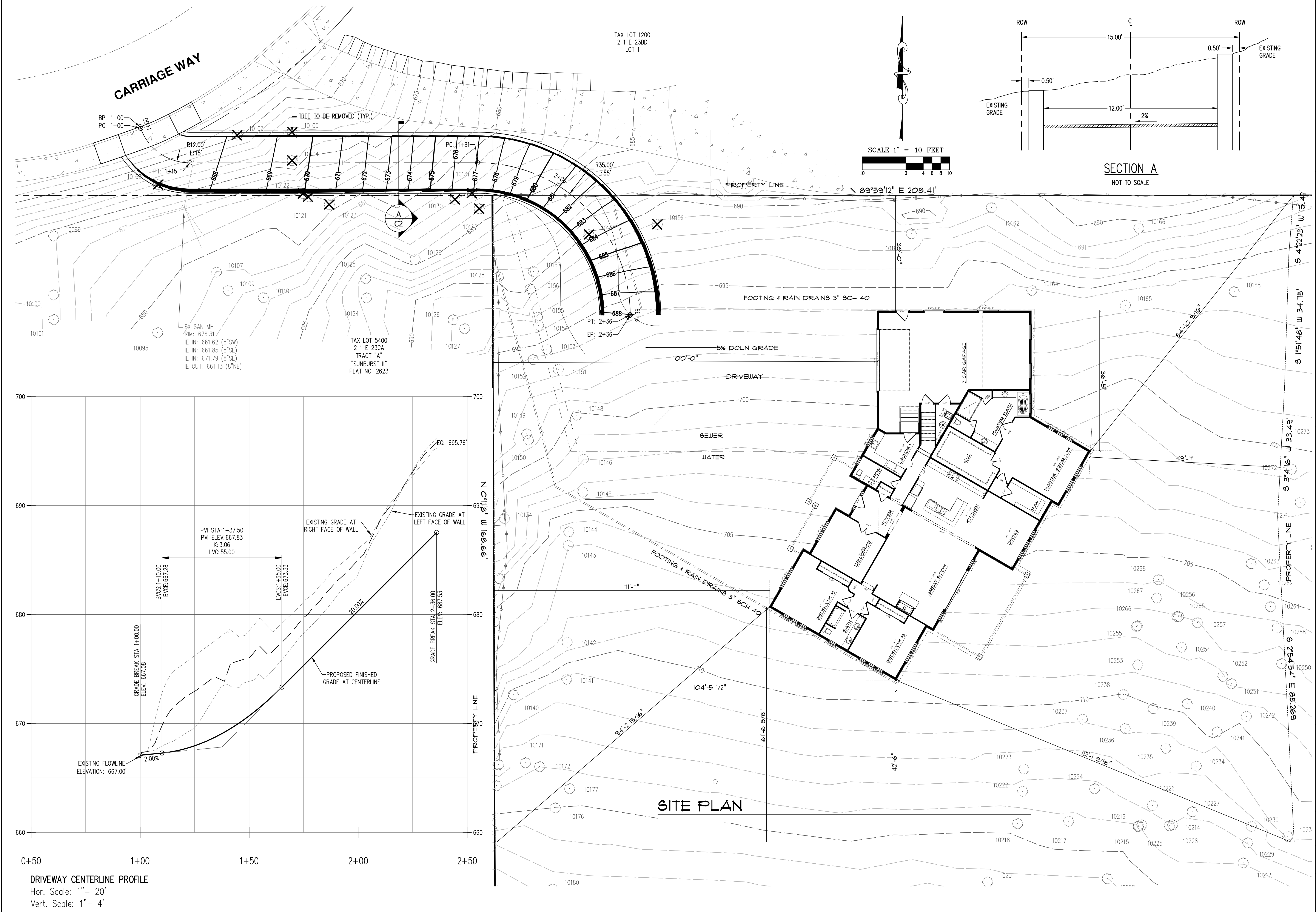

AKS
 AKS ENGINEERING & FORESTRY, LLC
 2205 SW HERMAN RD STE 100
 TUALUMIN, OR 97062
 P: 503.563.6151
 F: 503.563.6152
 aks-eng.com

PACIFIC GRAND DEVELOPMENT
1875 CARRIAGE WAY
WEST LINN OREGON
 CLACKAMAS COUNTY TAX MAP 25123CA
 TAX LOT 2101

PRELIMINARY DRIVEWAY
PLAN & PROFILE

DESIGNED BY: WJD
 DRAWN BY: WJD
 CHECKED BY: CEG
 SCALE: AS NOTED
 DATE: 02/10/2017
 REGISTERED PROFESSIONAL ENGINEER
 NOT FOR CONSTRUCTION
 SEPT. 14, 1998
 CHARLES EDWARD GREGORY
 RENEWS: JUNE 30, 2017
 REVISIONS:

JOB NUMBER
5617
 SHEET
C2