

# Stormwater Drainage Report

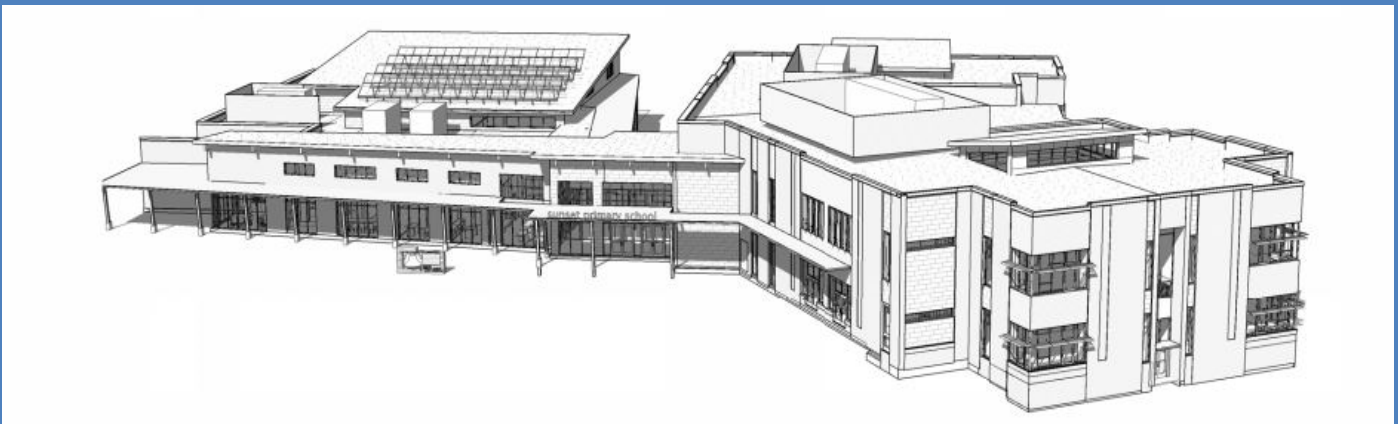
## Sunset Primary School

Prepared for: West Linn Wilsonville School District

Prepared by: Andrew Chung, Matt Johnson

Project Engineer: Mark Wharry, PE

July 2016 | KPFF Project #315087



## KPFF'S COMMITMENT TO SUSTAINABILITY

As a member of the US Green Building Council, a sustaining member of Oregon Natural Step, and a member of the Sustainable Products Purchasers Coalition, KPFF is committed to the practice of sustainable design and the use of sustainable materials in our work.

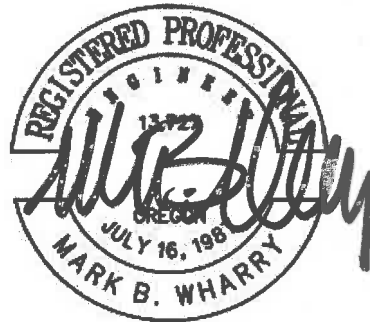
When hardcopy reports are provided by KPFF, they are prepared using recycled and recyclable materials, reflecting KPFF's commitment to using sustainable practices and methods in all of our products.



## Designer's Certification and Statement

"I hereby certify that this Stormwater Management Report for the Sunset Primary School project has been prepared by me or under my supervision and meets minimum standards of the City of West Linn and normal standards of engineering practice. I hereby acknowledge and agree that the jurisdiction does not and will not assume liability for the sufficiency, suitability, or performance of drainage facilities designed by me."

Mark Wharry, PE



EXPIRES 6/30/18

This page left blank for double sided printing

# Table of Contents

I.	Project Overview and Description .....	5
	Existing Site Drainage Basins .....	5
	New Site Drainage Basins .....	6
II.	Methodology .....	8
	Design Criteria .....	8
	Pre-Developed Conditions.....	8
	Infiltration Prevention .....	8
	Treatment Methodology .....	9
	Detention Methodology .....	9
	Proposed Stormwater Treatment & Detention Facility .....	9
III.	Analysis .....	10
	Site Hydrology & Hydraulic Analysis.....	10
	Stormwater Treatment.....	11
	Stormwater Detention .....	11
IV.	Conveyance.....	13
V.	Conclusions .....	13

## Tables and Figures

Figure 1: Existing Site Drainage Basins and Discharge .....	5
Figure 2: Sunset area offsite public storm drains .....	6
Figure 3: Sunset School new site drainage basins and discharge .....	6
Figure 4: Sunset neighborhood area downstream basin .....	7
Table 1: 24-Hour Rainfall Depths (Source: City of West Linn Surface Water Management Plan).....	11
Table 2: Detention Facility Design Parameters .....	12
Table 3: Detention Flows.....	12
Table 4: Sunset Primary School Detention Storage Depths.....	12
Table 5: Sunset Primary School Peak Stormwater Discharge Rates .....	14

## **Appendices**

### Appendix A

Figures

### Appendix B

- Hydrologic Analysis
- Geosynthetic Clay Liner Specifications

### Appendix C

- Geotechnical Report Prepared by Carlson
- Impervious Storm Facility Letter by Carlson

### Appendix D

Operations & Maintenance Report

### Appendix E

Offsite Stormwater Drainage Summary Memo

# I. Project Overview and Description

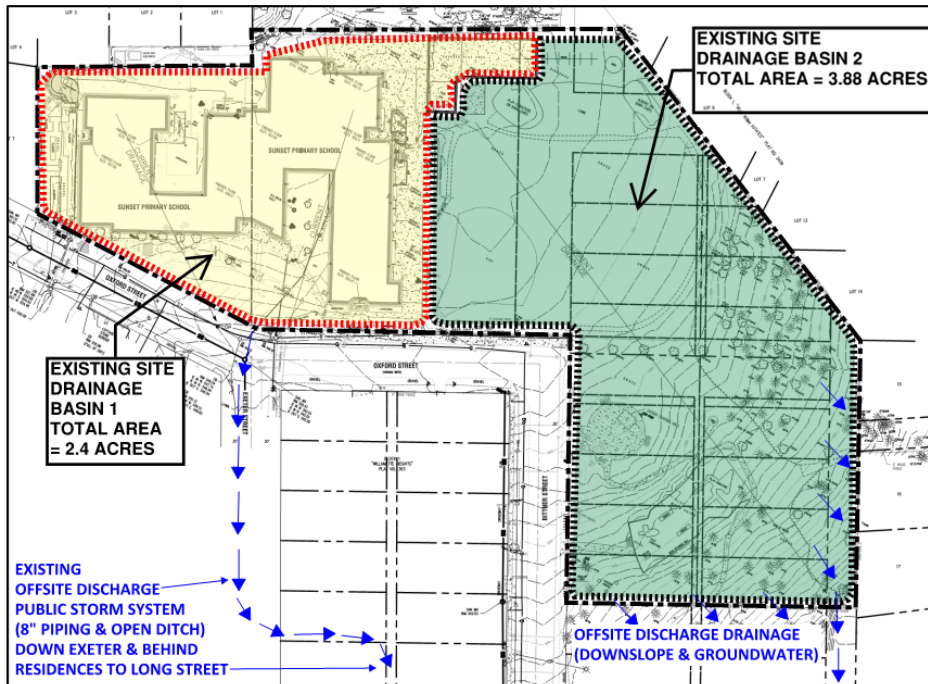
The Sunset Primary School project is located at 2531 Oxford St. West Linn, Oregon. Currently, the site is occupied by the existing Sunset Primary school, baseball field, playground equipment, and wooded area. The proposed project site is bordered to the south by Oxford and Bittner Streets. On the west, north and east sides of the site, the adjacent properties are composed of developed residential parcels. Currently, stormwater runoff from the project site is served by catch basins and surface runoff to the public storm system on Exeter Street and Oxford Street with no water quality or flow control.

The proposed project is the entire replacement of the Sunset Primary school building, asphalt parking lots, sidewalks, landscape, plays areas, and sports fields. All of this redevelopment will require stormwater treatment and detention. The proposed development will be served by an adequately sized stormwater facility in order to meet City of West Linn Design Standards Section 2 Storm Drain requirements. In addition to the on-site improvements, the City of West Linn requires public utility and street improvements.

For the purposes of additional clarification, four figures have been prepared to graphically illustrate how stormwater drains from the Sunset Primary School site. The Sunset site is fundamentally divided into two drainage basins. The sections below demonstrate how stormwater currently drains and how the revised basins would drain stormwater with the proposed new development. These pre-development and post-development configurations are described below.

## Existing Site Drainage Basins

Drainage Basin 1, shown in Figure 1 below, is comprised of the west side of the site and consists of the existing school building and surrounding paved area. This basin is approximately 2.4 acres, is largely impervious and currently includes no storm treatment or detention facilities.



Drainage Basin 2 for the existing school is comprised of the east and southeast portions of the site. These areas are predominantly open field and tree areas. As Figure 1 shows, this area is approximately 3.88 acres. There are no storm collection facilities in this area and all stormwater falling in this area drains down-gradient either by overland surface flow or infiltration subdrainage to the southeast.

Figure 1: Existing Site Drainage Basins and Discharge

Due to the impervious nature of the basin (predominantly roofs and pavements), essentially all storm drainage is collected onsite and discharges in an uncontrolled manner to a relatively marginal public storm drainage system that runs down Exeter Street to the south.

This public system is comprised of a combination of 8-inch gravity pipe segments with portions of open ditch sections. The Exeter Street system eventually is routed behind a row of residences and connects to a 24-inch main storm system in Long Street (shown in Figure 2).

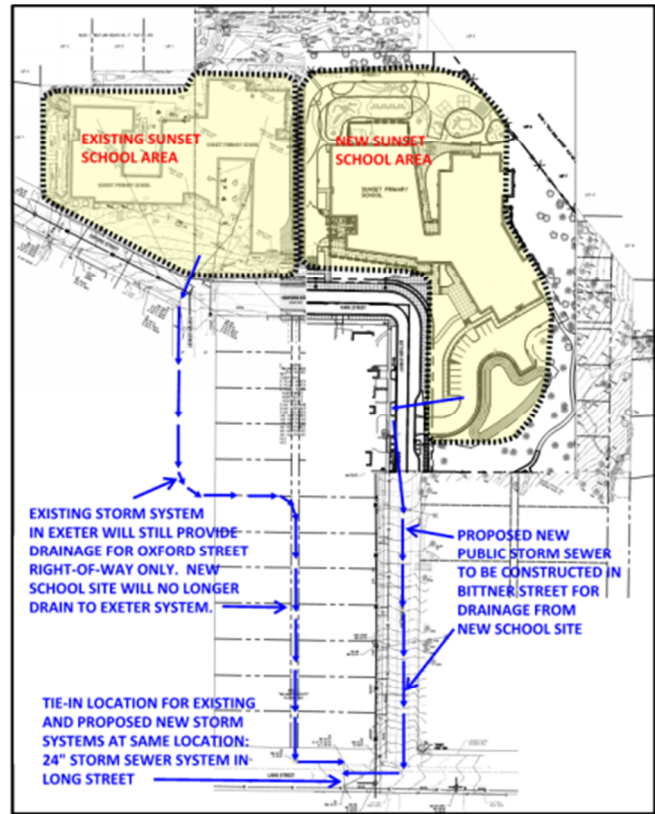


Figure 2: Sunset area offsite public storm drains

### New Site Drainage Basins

As Figure 3 illustrates, the new proposed school development shifts and expands the existing Drainage Basin 1 to the east, which is largely composed of the new impervious paving and roof areas. The overall area of Drainage Basin 1 is approximately 5.0 acres (or 2.6 acres larger than the pre-development condition).

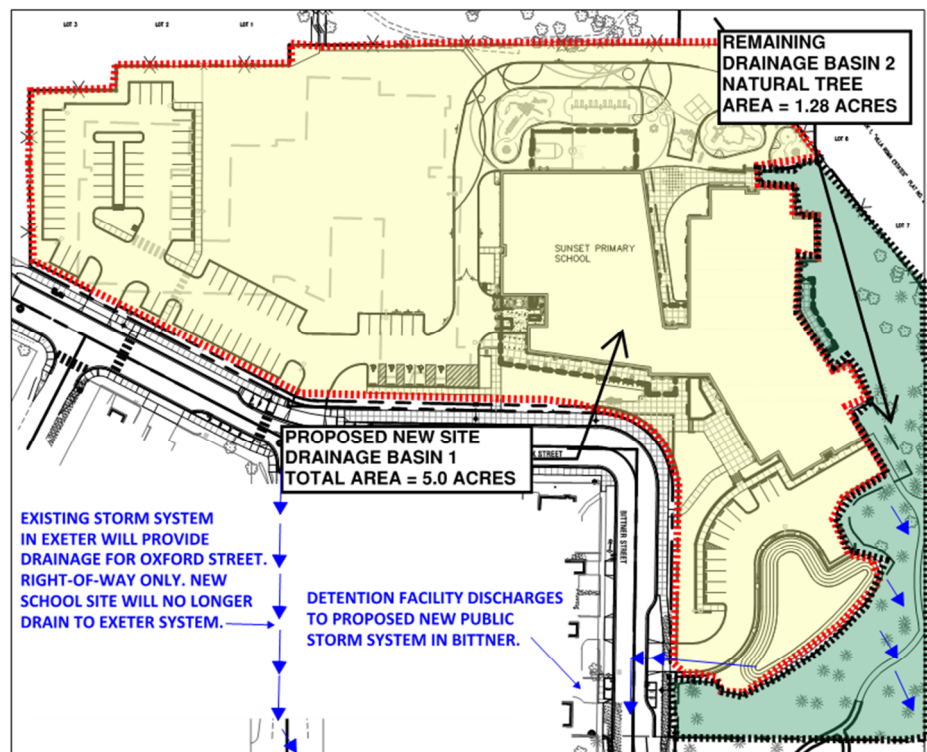


Figure 3: Sunset School new site drainage basins and discharge



Note that with the reconfigured school layout, the proposed play field has been relocated to the west side of the site. The field is relatively flat and will be natural grass turf surface.

With the expansion of Drainage Area 1 to the east, the remaining Drainage Area 2 has been reduced from 3.88 acres to 1.28 acres. This reconfiguration of the site drainage basins will have the following impacts:

- A stormwater treatment and detention facility will be utilized for collection and treatment of stormwater from the enlarged Drainage Basin 1.
- A new public storm sewer will be constructed in Bittner Street to convey the Sunset stormwater discharge from the treatment and detention facility to Long Street to tie into the same discharge location as the existing Sunset school site (shown in Appendix A-3 Exhibit 3).
- The reduction of Drainage Area 2 will reduce the current level of area contributing to stormwater infiltration and migration down-gradient to the southeast. More rainwater in this area will be captured, treated, and detained for discharge to the public storm sewer system.

Figure 4 shows the estimated entire drainage basin for the Long Street system. (Note that the boundaries are approximate and have been estimated from the City of West Linn map system.) This figure illustrates the additional area of 2.6 acres added to the overall 45 acre basin.

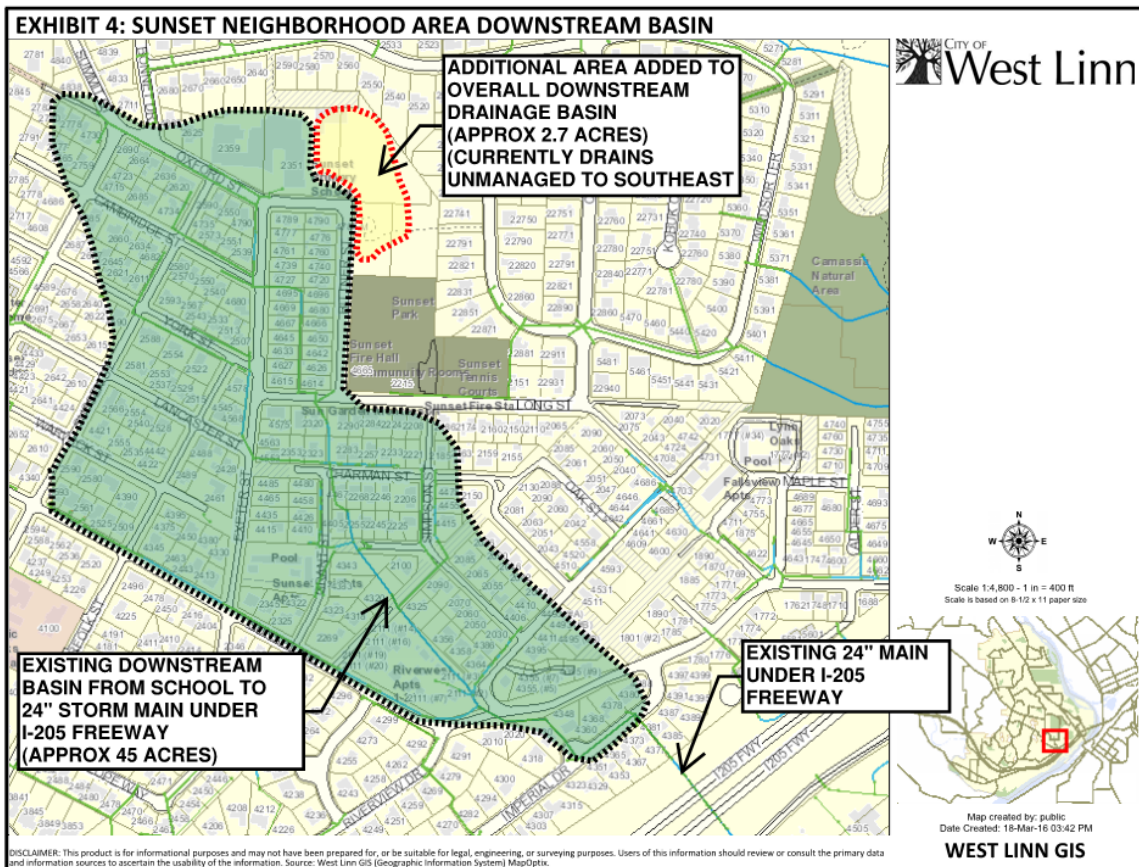


Figure 4: Sunset neighborhood area downstream basin

## II. Methodology

### Design Criteria

The proposed project will create impervious areas that will require a stormwater facility to treat and detain the runoff produced. The City of West Linn Design Standards requires all new construction to mitigate the impact of the new impervious areas in vegetated stormwater facilities to address both treatment and detention of stormwater. Per Sections 2.0010 and 2.0013 of the City Public Works Standards, the key applicable general design requirements and minimum criteria are outlined below (summarized for brevity).

- Surface or subsurface drainage caused by development shall not be allowed to flow over adjacent property but shall be collected and conveyed in an approved manner to an approved point of disposal.
- The approved point of disposal for all stormwater may be a storm drain, or detention or retention pond approved by the City Engineer. Existing open channels are approved points of disposal after the stormwater has been treated.
- The peak discharge from the property may not be increased from conditions existing prior to the proposed development.
- Retention/detention facilities are required where necessary to maintain surface water discharge rates at or below the existing design storm peak discharge rate.
- Detention facilities shall be designed to provide storage up to the 25-year storm event, with the safe overflow and conveyance of the 100-year storm event. Allowable post-development discharge rate for the 2, 5, 10 and 25-year events shall not exceed the pre-development discharge rates.
- Water Quality (Treatment) Facilities are required to meet the design requirements of the current City of Portland Stormwater Management Manual.
- For onsite conveyance piping, the piping must be designed to safely convey the 100-year design storm.

### Pre-Developed Conditions

The pre-developed conditions for this storm analysis are based on existing topography and the assumed Lewis and Clark condition of zero development. This pre-development assumption allows a comparison such that the post-developed run-off rates for a given area mimic that of woods in fair condition. These are the rates that the post developed run-off rates are compared to.

### Infiltration Prevention

Infiltration under the proposed stormwater facility will be prevented by an impermeable geosynthetic clay liner (GCL) installed under the facility. This GCL is a manufactured product consisting of two layers of non-woven geotextile fabric surrounding a layer of lower permeability sodium bentonite needle punched together. The liner products typically come in 15- to 20-foot wide rolls and are laid down in an overlapping fashion to create a low-permeability layer. There are a number of manufacturers for this type of product including Terrifix Geosynthetics, CETCO Lining Technologies, etc. The liner specified for the Sunset project is Bentomat DN manufactured by CETCO Lining Technologies or approved equal.

These manufactured liner materials are a good alternative to conventional compacted clay liner by replacing a thick section of compacted clay with a thin layer of pure sodium bentonite. One truckload of GCL is equivalent to 150 truckloads of compacted clay. Typical lining applications include canals, storm water facilities and wetlands. Specified hydraulic conductivity of the liner material (per ASTM D5887) is  $5 \times 10^{-9}$  cm/sec or approximately 0.000007 inches/hour. The GCL will be overlain with a layer of non-woven geotextile, pea gravel, and perforated collection piping that will collect storm water infiltration through the planting media and convey it to the discharge piping system.

Manufacturer's installation instructions for the GCL system include typical overlapping details for accommodating pipe penetrations and structures within the liner footprint. Note that no trees will be planted with the stormwater facility lined footprint. The 18-inch thick layer of growing media will support the water quality plantings in the facility. Standard manufacturer specifications and installation guidelines have been included as an appendix.

## Treatment Methodology

The City of West Linn Design Standards reference City of Portland Stormwater Management Manual (SWMM) requirements for treatment of the "pollution reduction" rain event. This event is defined as two thirds of the 2-year storm event and corresponds to a 24-hour rainfall event of 0.85 inches. The required Water Quality treatment area is calculated using the City of Portland Presumptive Approach Calculator (PAC).

Per correspondence with BES, the PAC Calculator may be used for drainage areas greater than 1 acre and does not affect the calculated peak flows for such an area. The 1 acre exceedance warning is purely internal for the Engineer to evaluate the facility size. As stated in the PAC user manual, the sizing of the facility still requires an engineering evaluation, which is the intent of this report. As shown in the PAC Calculations (Appendix B) the surface capacity is only ~26% used for the water quality storm in the proposed basin design. This shows that the facility is oversized for the water quality storm and provides extra capacity. In addition to the extra capacity of the facility, the design infiltration rate of the growing media and infiltration rate of the native soil has had a safety factor of 2 applied for additional conservative calculations.

## Detention Methodology

The West Linn Design Standards for Flow Control state that the "post development discharge rate for the 2, 5, 10, and 25 year events shall be that of the pre-development discharge rate." This project is analyzed as one basin (Basin 1 in Exhibit 3 in the above sections) based on proposed grades to convey all on-site stormwater to the facility in the southeast corner of the site. Based on the stormwater facility design and shape, detention volumes were calculated using standard engineering software AutoDesk Storm and Sanitary Analysis 2016 (SSA) consistent with the City of Portland Stormwater Management Manual.

## Proposed Stormwater Treatment & Detention Facility

To address the treatment and detention requirements, a single combined stormwater treatment and detention facility is proposed for the site. The facility has a flat bottom area of 3,445 square feet and has interior side slopes of 3H:1V. The total depth of the facility is 4'-6" and the volume is appropriated as follows:

- 0" - 6" Treatment depth.
- 6" – 38" Detention storage (2-year to 25-year storms).
- 38" – 40" 100-year storm overflow depth.
- 40" - 54" Freeboard.

The selection of the stormwater treatment and detention facility at the Sunset site is a standard best-management practice for stormwater. These facilities are very common and typical to all new development, including schools. The function of these facilities is to provide both the water quality and water quantity requirements mandated by the City of West Linn Public Works Design Standards.

Flow will be controlled out of the facility using an orifice control structure which is installed inside a flow control manhole. This orifice assembly also has an overflow to accommodate 100-year storm flows. In addition, there is a second redundant emergency overflow structure completed separate from the flow control manhole.

With respect to the grading of the facility, the surrounding top of the facility is at elevation 539.5-feet which is the approximate grade through the center of the existing play equipment area. The proposed location of the facility has been developed with regard to the existing site topography and has been influenced by the following factors:

- The facility needs to be positioned at the low point of the site to collect the complete runoff from all impervious areas of the site.
- The facility needs to be positioned to allow placement of the flow control and overflow structure to be connected to the public storm sewer system.
- The facility needs to be accessible and near a roadway for maintenance access.
- The facility needs to be separated from school recess activities.

### III. Analysis

The hydrologic and hydraulic analyses were generated from a variety of sources including existing maps, field data, computer programs, standards, and reference manuals by experienced professionals.

The hydraulic analyses were performed in accordance with City of West Linn Design Manual using the SBUH method with a 24-hour NRCS Type 1A synthetic rainfall distribution. As outlined above, the calculations were executed with the computer program AutoDesk Storm and Sanitary Analysis 2016 and City of Portland's PAC Calculator. These methods were used to determine peak flows, pipe conveyance, facility sizing, and orifice flow control.

#### Site Hydrology & Hydraulic Analysis

Development of the site hydrologic and hydraulic analyses was based on the following parameters:

- The total impervious areas for the site are approximately 2.98 acres.
- C-value for impervious areas = 0.98.
- Time of concentration (ToC) = 5 minutes.

The 24-hour rainfall depths used in this study were obtained from the City of West Linn Surface Water Management Plan.

Design Storm	24 Hour Rainfall (inches)
2-year	2.5
5-year	3.0
10-year	3.4
25-year	3.9
100-year	4.5

Table 1: 24-Hour Rainfall Depths (Source: City of West Linn Surface Water Management Plan)

## Stormwater Treatment

This project will treat stormwater in the bottom planter area of the combined treatment and detention facility. Storage depth will be the first 6 inches of the proposed stormwater facility. The proposed facility has been designed using AutoDesk SSA and the area required for water quality has been verified using the City of Portland PAC Calculator (See Appendix B).

The facility will provide filtration treatment of the stormwater through a combination of plant bio-treatment and growing soil media filtration. The bottom of this facility is recessed 6 inches from the outlet pipe and becomes essentially a stormwater planter to hold a pre-determined quantity of water comprising the “treatment” storm as defined by regulation. For regular small storms, rainwater enters the planter and is cleaned by residence time within the plant environment and by percolating down through the soil media.

Using the pollution reduction storm of 2/3 of the 2-year design storm, the following results were calculated for the treatment of stormwater at the Sunset site:

- 24-hour treatment storm rainfall = 1.67 inches.
- Pollution reduction peak rainfall intensity (City of Portland SWMM Appendix E) = 0.19 in/hr.
- Pollution reduction peak flow = 0.53 cfs.
- Pollution reduction treatment area = 3,445 square feet.

As seen in the PAC calculations, a facility configuration D was chosen in which a perforated pipe will catch and stormwater that infiltrates through the growing media and convey to the flow control manhole. Underneath the pipe and gravel bedding will be a geosynthetic clay liner to prevent rainwater from infiltrating further into the native soil. This design was incorporated into the water quality PAC calculation (for treatment) as well as the orifice (SSA) detention calculations.

## Stormwater Detention

The stormwater facility has been designed to detain and discharge per the City of West Linn Stormwater Manual. Discharge is controlled through a multiple orifice flow control manhole in which the post 2, 5, 10, and 25 year discharge rate is equal to or improved upon from its pre development conditions. The facility provides storage for up to the 25 year storm and approximately 1.20-feet of additional freeboard to safely overflow the 100 year storm event. See Appendix B for detailed analysis of the Detention facility.

Pond ID	Facility Bottom Area (SF)	Side Slope (H:V)	Total Depth (FT)
1	3445	3:1	4.5

Table 2: Detention Facility Design Parameters  
\*See Appendix B for additional details

For temporarily detaining flows from heavy storms, this facility does not depend on infiltration, and all the storage calculations are based on surface volumes and do not account for the additional storage within the voids of the drain and rock and growing medium. The facility is graded to provide storage volume for onsite stormwater to be temporarily stored and metered out slowly so that peak discharge from the property is substantially decreased from its existing condition. This is accomplished by providing ponding capacity within the facility and routing the stormwater discharge through an outlet orifice structure that meters the flow out slowly. The table below illustrates the peak existing condition and proposed new development storm discharge rates.

Development Condition	2 YEAR Qmax (cfs)	5 YEAR Qmax (cfs)	10 YEAR Qmax (cfs)	25 YEAR Qmax (cfs)	100 YEAR Qmax (cfs)
Pre-Development Flows (Lewis and Clark Existing Site – See App A Fig 4)	0.40	0.70	0.97	1.35	1.84
Proposed Development Facility Inlet Flows (un-detained Post Developed – See App A Basin 1 Fig 5)	1.86	2.37	2.80	3.35	4.02
Proposed Facility Outlet Flows (detained flows Post Developed – See App A Basin 1 Fig 5)	0.28	0.47	0.66	0.94	-
Undeveloped Area (Area within property that will be undisturbed – See App A Basin 2 Fig 5)	0.11	0.20	0.27	0.38	-

Table 3: Detention Flows

As Table 3 illustrates, offsite peak stormwater flow rates from the new school are significantly reduced below the pre-development discharge rates. The proposed detention facility at Sunset has a maximum graded depth of 4.0 feet (bottom elevation of 535.0 to top of facility elevation of 539.5). The following Table 4 shows these ponding depths for the various design storms.

Design Storm	Water Surface Elevation	Water Depth	Freeboard
Facility Bottom	535.00	0.00'	4.50'
Treatment(6-Month)	535.50	0.50'	4.00'
2-Year	537.43	2.46'	2.04'
5-Year	537.73	2.74'	1.76'
10-Year	537.89	2.89'	1.61'
25-Year	538.10	3.11'	1.39'
100-Year	538.29	3.30'	1.20'

Table 4: Sunset Primary School Detention Storage Depths

## IV. Conveyance

All of the components of the storm system are sized to convey the 100-year design storm (Rational Method) per the City of West Linn Design Manual. Below outlines the methods used for sizing flows and comparing pipe capacity:

Basin component	Method of Calculation	Reference Code
Basin Flow	Rational Method	Table 6.1, SDFDM*
Pipe Capacity	Manning's $Q = \frac{1.49}{n} A * R^{2/3} \sqrt{S}$	Equation 8.2, SDFDM*

\* = City of Portland Sewer and Drainage Facilities Design Manual (revised June 2007)

For pipes that have less than 3 feet of cover, ductile iron will be used in lieu of PVC.

Below is the information used for the conveyance calculations:

- The precipitation for the 100-year storm is 3.45 in/hr per ODOT Zone 8 IDF Curve.
- The “c” value for pavement/roofs is 0.98 and the “c” value for landscaped areas is 0.25.
- The minimum time of concentration is 5 minutes.

## V. Conclusions

Based on the compliance with the City of West Linn Stormwater Management Manual, City of West Linn Design Standards, City of Portland SWMM, feasibility, and proper engineering techniques, the stormwater runoff for the Sunset Primary School project will be effectively managed. A single combined stormwater treatment and detention facility will be used for water quality and water quantity. This determination is supported by the PAC and SSA calculations. A geosynthetic clay liner will be used to prevent stormwater infiltration into the native soil. The proposed facility discharge rates are controlled to the code required pre-development rates, and are substantially lower than the current school discharge rates. No downstream impacts are anticipated.

In addition, Table 5 below was developed to compare existing discharge rates to the Exeter/Long Street system to the proposed new discharge rates. Although the drainage area size increased by 2.7 acres, the overall discharge flows are lower.

As Table 3 illustrates, offsite peak stormwater flow rates from the new school are significantly reduced below the existing discharge rates. Discharge to the City of West Linn Long Street storm sewer system has been detained to levels below the existing discharge flows to the Exeter system. And due to the reduction of area for Drainage Basin 2, runoff on the west side of the site has been reduced as well.

Design Storm	Existing School Site Peak Stormwater Discharge Offsite		Proposed New School Site Peak Stormwater Discharge Offsite	
	Drainage Basin 1 (No detention – discharge to Exeter system)	Drainage Basin 2 (Downslope runoff from field & tree area)	Drainage Basin 1 (New detention to Lewis & Clark level– discharge to new Bittner storm sewer)	Drainage Basin 2 (Downslope runoff from field & tree area – including bottom of detention facility)
2-Year	1.22 cfs	0.27 cfs	0.28 cfs	0.11 cfs
5-Year	1.49 cfs	0.46 cfs	0.47 cfs	0.20 cfs
10-Year	1.72 cfs	0.63 cfs	0.66 cfs	0.27 cfs
25-Year	2.00 cfs	0.86 cfs	0.94 cfs	0.38 cfs
100-Year	2.34 cfs	1.16 cfs	1.67 cfs	0.51 cfs

Table 5: Sunset Primary School Peak Stormwater Discharge Rates

- Drainage for the new development will be collected and conveyed in an approved manner to an approved point of disposal. On the proposed Sunset site, storm drainage is discharged and connected to the same Long Street system to which it is currently routed.
- The proposed combined treatment and detention facility is not designed nor intended to infiltrate heavy stormwater events. Some natural infiltration will occur at the reduced rate of the facility growing media and the majority of stormwater flow will be collected and discharged offsite.
- The peak discharge from the school development has been appropriately detained and discharged to the City system such that peak flows discharged downstream (Long Street system) will not be increased from conditions existing prior to the proposed development.
- Appropriate (redundant) overflow facilities will be incorporated into the discharge structures of the facility.
- Water Quality (Treatment) Facilities have been designed per the requirements of the current City of Portland Stormwater Management Manual.
- Onsite conveyance piping has been designed to safely convey the 100-year design storm.



# Appendix A

## Figures

- Vicinity Map
- Basin Map
- Storm Sewer Plans
- Pre-Developed Drainage & Discharge
- Post-Developed Drainage & Discharge



**PROJECT SITE**

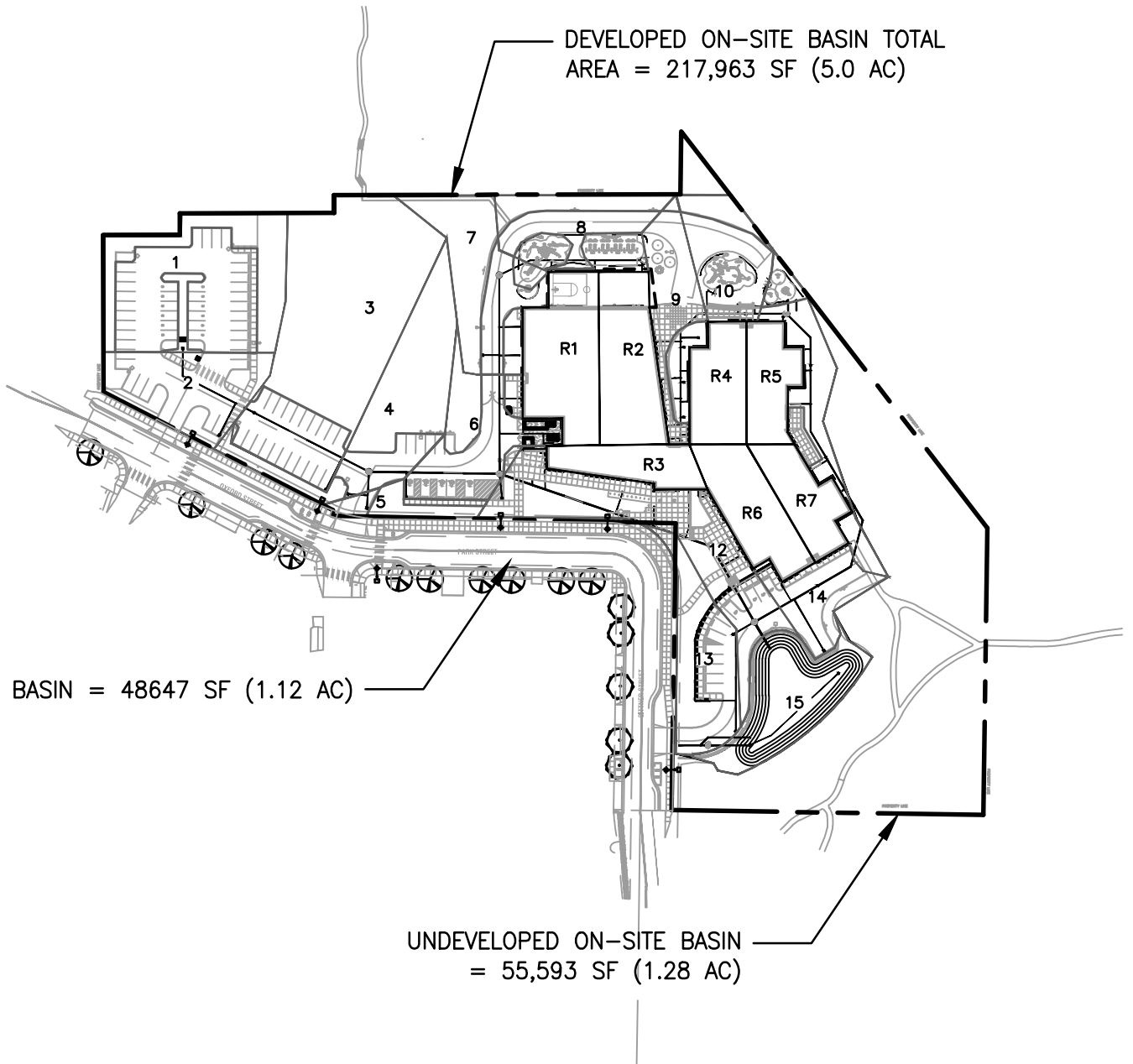
# VICINITY MAP

N.T.S



SHEET NO.  
**FIG 1**

File: N:\c\p\2015\315087-Sunset-Primary-School\PROJ-INFO\Planning-Design\PRIVATE\01-Stormwater\BASIN\_MAP.dwg TAB:FIG-2



**ON-SITE BASIN DATA**

TOTAL AREA: 217963 SF  
 IMPERVIOUS AREA: 128000 SF

BLDG AREA: 45603 SF  
 BASIN 1: 20068 SF  
 BASIN 2: 9435 SF  
 BASIN 3: 29456 SF  
 BASIN 4: 14157 SF  
 BASIN 5: 2787 SF  
 BASIN 6: 9261 SF  
 BASIN 7: 11338 SF  
 BASIN 8: 9790 SF  
 BASIN 9: 7996 SF  
 BASIN 10: 7513 SF  
 BASIN 11: 7995 SF  
 BASIN 12: 15405 SF  
 BASIN 13: 9003 SF  
 BASIN 14: 5504 SF  
 BASIN 15: 11057 SF

R1: 9781 SF  
 R2: 8705 SF  
 R3: 4606 SF  
 R4: 5657 SF  
 R5: 4922 SF  
 R6: 6950 SF  
 R7: 4982 SF

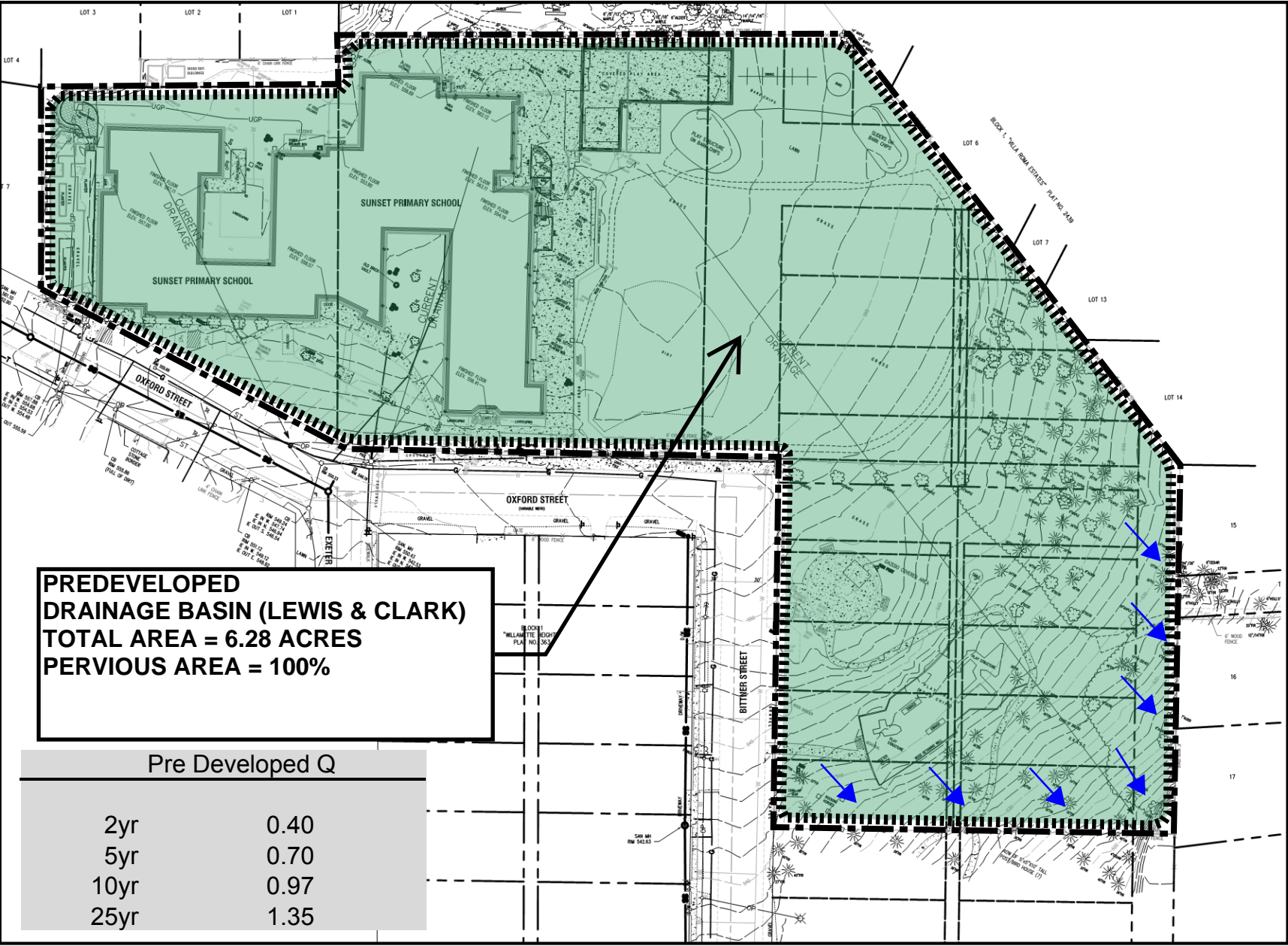
SUNSET PRIMARY SCHOOL

FIG-2

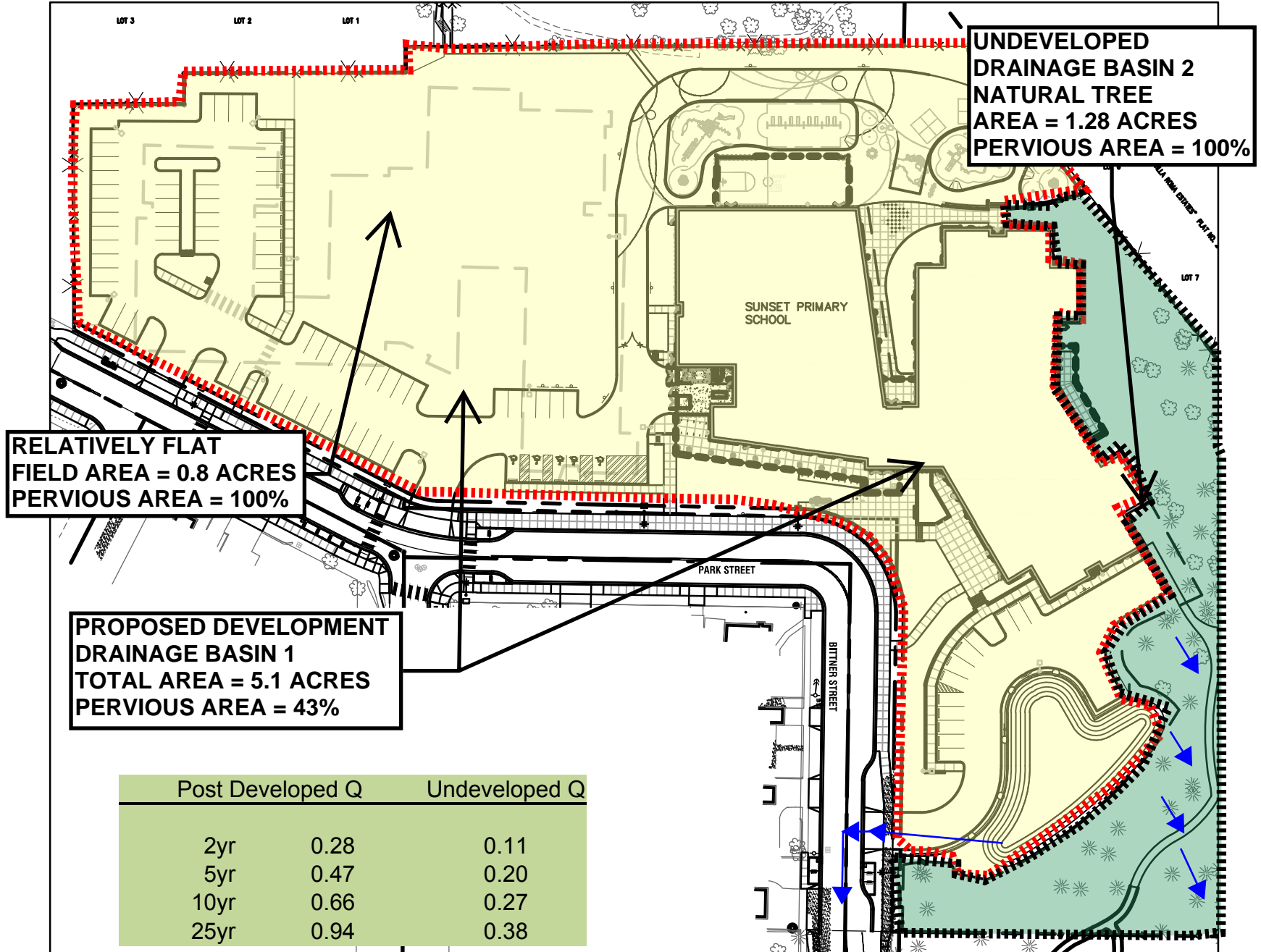
**STORMWATER BASIN MAP**

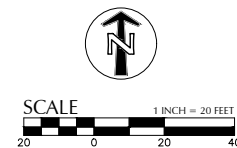
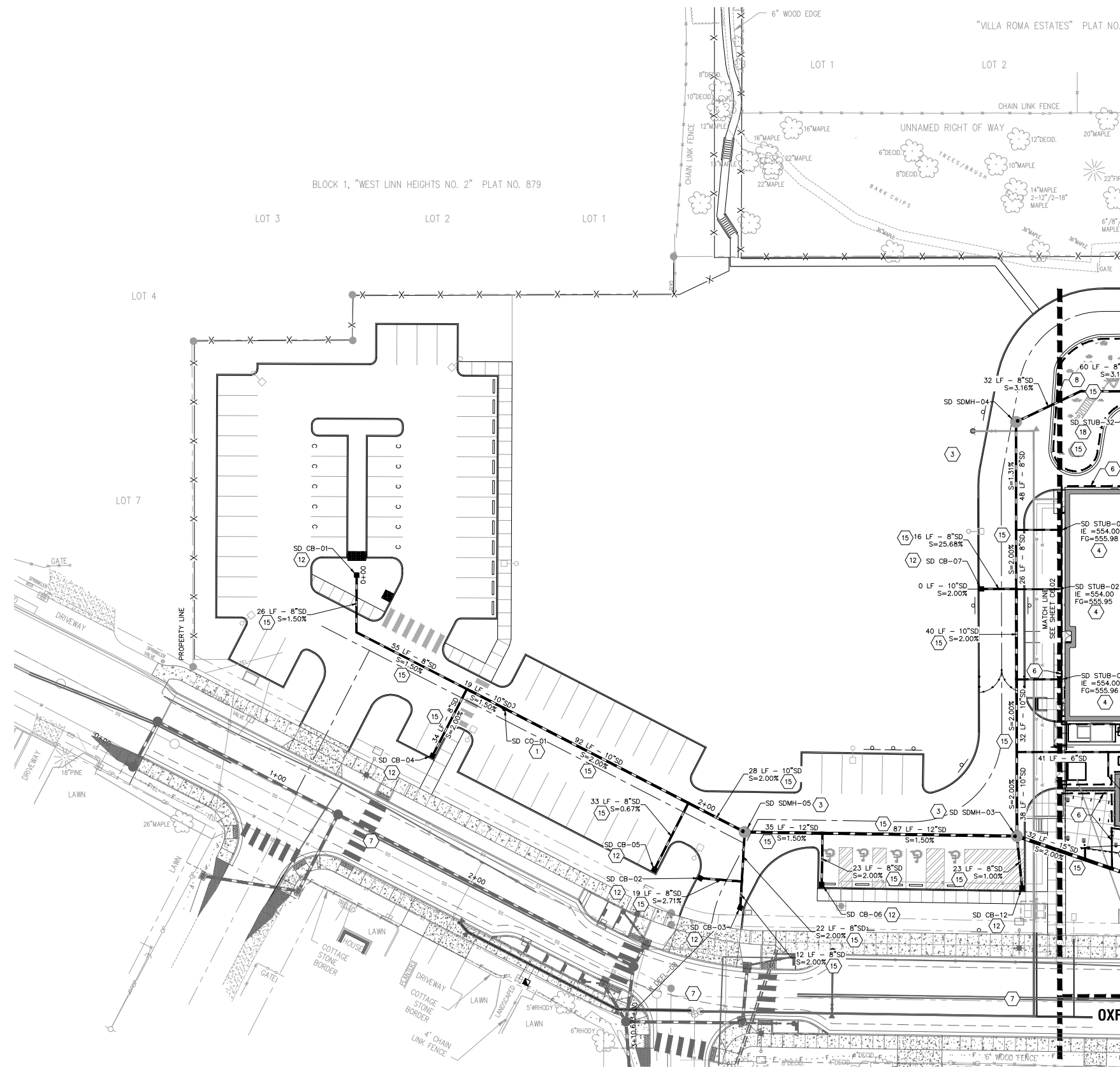


SUNSET SCHOOL PRE-DEVELOPED DRAINAGE BASIN & DISCHARGE



POST-DEVELOPED SUNSET SCHOOL DRAINAGE BASINS & DISCHARGES





**PIPE LEGEND**

PROPOSED	EXISTING

- STORM KEYNOTES**
- INSTALL STANDARD CLEANOUT.
  - INSTALL FLOW CONTROL MANHOLE.
  - INSTALL STANDARD 48" DIAMETER MANHOLE.
  - CONNECT TO BUILDING ROOF DRAIN STUB WITH PVC LATERAL. LATERAL TO BE 6" DIAMETER UNLESS OTHERWISE NOTED ON PLANS. SLOPE AT A MINIMUM OF 2%. SEE PLUMBING PLANS FOR CONTINUATION. CONFIRM DOWNSPOUT LOCATION WITH ARCHITECTURAL AND PLUMBING PLANS PRIOR TO CONSTRUCTION.
  - DAYLIGHT STORM PIPE.
  - PROVIDE BUILDING FOOTING DRAIN SYSTEM AND CONNECT TO STORM DRAIN WITH SOLID WALL PVC PIPE, S=1% MINIMUM, SIZE TO MATCH SUB-DRAIN. INSTALL BACKWATER VALVE.
  - SEE PUBLIC IMPROVEMENT (PI) PLANS FOR WORK IN RIGHT OF WAY (ROW).
  - CONNECT RETAINING WALL SUB-SURFACE DRAIN TO STORM SYSTEM WITH 4" SOLID WALL PVC.
  - PROVIDE TRENCH DRAIN.
  - TRENCH DRAIN POINT OF CONNECTION. SEE STRUCTURE TABLE FOR LOCATION.
  - PROVIDE AREA DRAIN (AD).
  - PROVIDE CATCH BASIN.
  - PROVIDE STANDARD DITCH INLET.
  - CONSTRUCT STORMWATER TREATMENT/DETENTION FACILITY.
  - PROVIDE PVC STORM DRAIN PIPE.
  - PROVIDE 4" PVC PERF DRAIN IN 8" DRAIN ROCK ENVELOPE BEHIND RETAINING WALL.
  - PROVIDE DETENTION OVERFLOW STRUCTURE.
  - CONNECT TO EXTERIOR DOWNSPOUT AND PROVIDE CLEANOUT AT CONNECTION.

**(SD) STRUCTURE TABLE**

STRUCTURE ID	NORTH	EASTING	RIM ELEVATION	INVERT ELEVATIONS
AD-01	10120.56	10326.02	553.00	IE 8"(OUT) = 549.33 (W)
AD-02	10153.18	10326.02	553.00	IE 8"(OUT) = 549.33 (W)
AD-03	10185.81	10326.02	553.00	IE 8"(OUT) = 549.33 (W)
AD-04	10194.74	10339.59	553.27	IE 8"(OUT) = 549.33 (W)
AD-05	10225.15	10376.41	554.00	IE 8"(OUT) = 550.34 (S)
AD-06	10223.64	10392.06	554.00	IE 8"(OUT) = 550.33 (S)
CB-01	10184.61	9859.61	555.00	IE 8"(OUT) = 551.83 (S)
CB-02	10049.23	10013.05	551.55	IE 8"(OUT) = 548.55 (E)
CB-03	10036.04	10030.94	550.98	IE 8"(OUT) = 548.28 (N)
CB-04	10103.85	9893.48	555.09	IE 8"(OUT) = 551.28 (NE)
CB-05	10053.08	9992.58	551.00	IE 8"(OUT) = 549.00 (NE)
CB-06	10046.34	10067.33	552.30	IE 8"(OUT) = 547.95 (N)
CB-07	10178.40	10138.63	554.65	IE 8"(OUT) = 551.65 (E)
CB-08	9828.50	10374.46	544.34	IE 8"(OUT) = 539.84 (N)
CB-09	9903.30	10456.36	544.27	IE 8"(OUT) = 539.58 (NW)
CB-11	10216.99	10383.57	551.78	IE 10"(IN) = 546.91 (W) IE 10"(OUT) = 546.91 (E)
CB-12	10044.82	10156.79	552.85	IE 8"(OUT) = 545.74 (N)
CO-01	10124.97	9925.70	555.78	IE 10"(IN) = 550.16 (NW) IE 10"(OUT) = 550.16 (SE)
CO-02	10098.77	10323.02	553.94	IE 8"(OUT) = 549.61 (N)
CO-03	10216.99	10344.59	554.05	IE 8"(IN) = 547.66 (W) IE 8"(OUT) = 547.66 (E)
CO-04	10169.03	10443.93	551.98	IE 10"(IN) = 545.01 (N) IE 10"(OUT) = 545.01 (S)
CO-05	10083.34	10458.14	550.73	IE 10"(IN) = 543.22 (NW) IE 12"(OUT) = 543.05 (SE)
CO-06	9963.71	10450.52	545.92	IE 12"(IN) = 540.08 (NE) IE 12"(OUT) = 540.08 (SW)
CO-07	9918.59	10371.86	545.89	IE 8"(OUT) = 538.98 (NE)
CO-08	9882.18	10469.92	533.04	IE 6"(OUT) = 532.50 (SW)
DI-01	9815.25	10387.66	535.50	IE 12"(OUT) = 531.97 (W) IE 6"(IN) = 531.97 (NE)
DL-01	9905.14	10406.12	537.62	IE 18"(IN) = 536.00 (NW)
FCMH-01	9815.18	10348.42	544.77	IE 12"(IN) = 531.78 (E) IE 12"(OUT) = 533.00 (W)
OFI-01	9822.44	10387.47	538.30	IE 12"(OUT) = 533.10 (W)
SDMH-01	9929.96	10391.59	545.93	IE 12"(IN) = 538.73 (NE) IE 18"(OUT) = 537.76 (SE) IE 15"(IN) = 539.72 (NW) IE 8"(IN) = 538.73 (SW)
SDMH-02	10000.37	10351.68	551.55	IE 15"(IN) = 541.33 (W) IE 15"(OUT) = 541.33 (SE)
SDMH-03	10067.98	10154.50	554.13	IE 12"(IN) = 545.76 (W) IE 15"(OUT) = 545.51 (E) IE 10"(IN) = 545.51 (N) IE 8"(IN) = 545.51 (S)
SDMH-04	10252.95	10154.08	555.75	IE 8"(IN) = 549.04 (NE) IE 8"(OUT) = 549.04 (S)
SDMH-05	10069.79	10032.91	552.43	IE 10"(IN) = 547.75 (NW) IE 12"(OUT) = 547.58 (E) IE 8"(IN) = 547.60 (S)
SDMH-06	10216.99	10421.58	552.24	IE 10"(IN) = 546.15 (W) IE 10"(OUT) = 546.15 (SE)

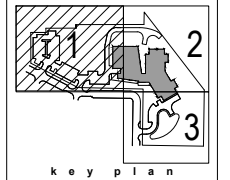
**WEST LINN WILSONVILLE**  
 2755 SW Borland Road  
 Tualatin, OR 97062  
 (503) 673-7995

**dowa IBI**  
 Dull Olson Weekes - IBI Group  
 Architects, Inc.  
 907 SW Stark Street Portland OR 97205 USA  
 Tel: 503.226.6950 Fax: 503.275.9192  
 www.dowa-ibigroup.com www.ibigroup.com

**kpff**  
 111 SW Fifth Ave., Suite 2500  
 Portland, OR 97204  
 Tel: 503.227.3251  
 Fax: 503.274.4682  
 www.kpff.com

**REGISTERED PROFESSIONAL**  
 13,787  
 DIGITAL SIGNATURE  
 MARY B. WHARTY  
 EXPIRES 6/30/16

**SUNSET REVISIONING**  
 West Linn Wilsonville School District  
 2351 Oxford St, West Linn, OR 97068  
 t: (503) 673-7988

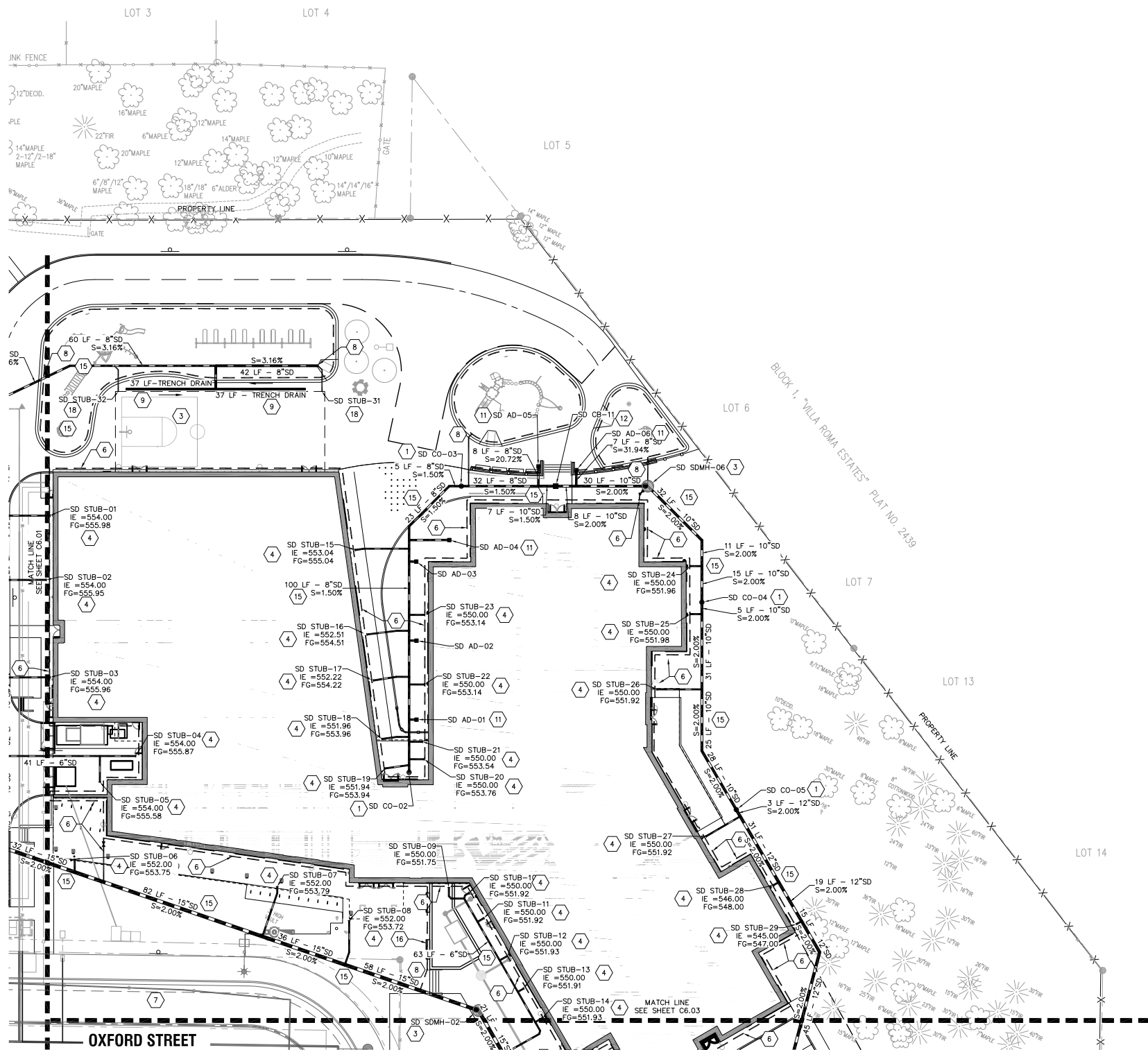


key plan

phase	Conformed Set
date	June 15, 2016
revisions	

project # 15015  
**STORM PLAN**  
**NORTHWEST**  
**C6.01**

8/17/2016 9:16:12 AM  
 N:\c2015\315007-Sunset-Primary-School\FILE-TRANS\IN\20150810-REV\15-08-10-WILWV-ARMS.rvt



**PIPE LEGEND**

PROPOSED	EXISTING

**STORM KEYNOTES**

- INSTALL STANDARD CLEANOUT.
- INSTALL FLOW CONTROL MANHOLE.
- INSTALL STANDARD 48" DIAMETER MANHOLE.
- CONNECT TO BUILDING ROOF DRAIN STUB WITH PVC LATERAL. LATERAL TO BE 6" DIAMETER UNLESS OTHERWISE NOTED ON PLANS. SLOPE AT A MINIMUM OF 2%. SEE PLUMBING PLANS FOR CONTINUATION. CONFIRM DOWNSPOUT LOCATION WITH ARCHITECTURAL AND PLUMBING PLANS PRIOR TO CONSTRUCTION.
- DAYLIGHT STORM PIPE.
- PROVIDE BUILDING FOOTING DRAIN SYSTEM AND CONNECT TO STORM DRAIN WITH SOLID WALL PVC PIPE, S=1% MINIMUM, SIZE TO MATCH SUB-DRAIN. INSTALL BACKWATER VALVE.
- SEE PUBLIC IMPROVEMENT (PI) PLANS FOR WORK IN RIGHT OF WAY (ROW).
- CONNECT RETAINING WALL SUB-SURFACE DRAIN TO STORM SYSTEM WITH 4" SOLID WALL PVC.
- PROVIDE TRENCH DRAIN.
- TRENCH DRAIN POINT OF CONNECTION. SEE STRUCTURE TABLE FOR LOCATION.
- PROVIDE AREA DRAIN (AD).
- PROVIDE CATCH BASIN.
- PROVIDE STANDARD DITCH INLET.
- CONSTRUCT STORMWATER TREATMENT/DETENTION FACILITY.
- PROVIDE PVC STORM DRAIN PIPE.
- PROVIDE 4" PVC PERF DRAIN IN 8" DRAIN ROCK ENVELOPE BEHIND RETAINING WALL.
- PROVIDE DETENTION OVERFLOW STRUCTURE.
- CONNECT TO EXTERIOR DOWNSPOUT AND PROVIDE CLEANOUT AT CONNECTION.

**(SD) STRUCTURE TABLE**

STRUCTURE ID	NORTHING	EASTING	RM ELEVATION	INVERT ELEVATIONS
AD-01	10120.56	10326.02	553.00	IE 8"(OUT) = 549.33 (W)
AD-02	10153.18	10326.02	553.00	IE 8"(OUT) = 549.33 (W)
AD-03	10185.81	10326.02	553.00	IE 8"(OUT) = 549.33 (W)
AD-04	10194.74	10339.59	553.27	IE 8"(OUT) = 549.33 (W)
AD-05	10225.15	10376.41	554.00	IE 8"(OUT) = 550.34 (S)
AD-06	10223.64	10392.06	554.00	IE 8"(OUT) = 550.33 (S)
CB-01	10184.61	9859.61	555.00	IE 8"(OUT) = 551.83 (S)
CB-02	10049.23	10013.05	551.55	IE 8"(OUT) = 548.55 (E)
CB-03	10036.04	10030.94	550.98	IE 8"(OUT) = 548.28 (N)
CB-04	10103.85	9893.48	555.09	IE 8"(OUT) = 551.28 (NE)
CB-05	10053.08	9992.58	551.00	IE 8"(OUT) = 549.00 (NE)
CB-06	10046.34	10067.33	552.30	IE 8"(OUT) = 547.95 (N)
CB-07	10178.40	10138.63	554.65	IE 8"(OUT) = 551.65 (E)
CB-08	9828.50	10374.46	544.34	IE 8"(OUT) = 539.84 (N)
CB-09	9903.30	10456.36	544.27	IE 8"(OUT) = 539.58 (NW)
CB-11	10216.99	10383.57	551.78	IE 10"(IN) = 546.91 (W) IE 10"(OUT) = 546.91 (E)
CB-12	10044.82	10156.79	552.85	IE 8"(OUT) = 545.74 (N)
CO-01	10124.97	9925.70	555.78	IE 10"(IN) = 550.16 (NW) IE 10"(OUT) = 550.16 (SE)
CO-02	10098.77	10323.02	553.94	IE 8"(OUT) = 549.61 (N)
CO-03	10216.99	10344.59	554.05	IE 8"(IN) = 547.66 (W) IE 8"(OUT) = 547.66 (E)
CO-04	10169.03	10443.93	551.98	IE 10"(IN) = 545.01 (N) IE 10"(OUT) = 545.01 (S)
CO-05	10083.34	10458.14	550.73	IE 10"(IN) = 543.22 (NW) IE 12"(OUT) = 543.05 (SE)
CO-06	9963.71	10450.52	545.92	IE 12"(IN) = 540.08 (NE) IE 12"(OUT) = 540.08 (SW)
CO-07	9918.59	10371.86	545.89	IE 8"(OUT) = 538.98 (NE)
CO-08	9882.18	10469.92	533.04	IE 6"(OUT) = 532.50 (SW)
DI-01	9815.25	10387.66	535.50	IE 12"(OUT) = 531.97 (W) IE 6"(IN) = 531.97 (NE)
DL-01	9905.14	10406.12	537.62	IE 18"(IN) = 536.00 (NW)
FCMH-01	9815.18	10348.42	544.77	IE 12"(IN) = 531.78 (E) IE 12"(OUT) = 533.00 (W)
OFI-01	9822.44	10387.47	538.30	IE 12"(OUT) = 533.10 (W)
SDMH-01	9929.96	10391.59	545.93	IE 12"(IN) = 538.73 (NE) IE 18"(OUT) = 537.76 (SE) IE 15"(IN) = 539.72 (NW) IE 8"(IN) = 538.73 (SW)
SDMH-02	10000.37	10351.68	551.55	IE 15"(IN) = 541.33 (W) IE 15"(OUT) = 541.33 (SE)
SDMH-03	10067.98	10154.50	554.13	IE 12"(IN) = 545.76 (W) IE 15"(OUT) = 545.51 (E) IE 10"(IN) = 545.51 (N) IE 8"(IN) = 545.51 (S)
SDMH-04	10252.95	10154.08	555.75	IE 8"(IN) = 549.04 (NE) IE 8"(OUT) = 549.04 (S)
SDMH-05	10069.79	10032.91	552.43	IE 10"(IN) = 547.75 (NW) IE 12"(OUT) = 547.58 (E) IE 8"(IN) = 547.60 (S)
SDMH-06	10216.99	10421.58	552.24	IE 10"(IN) = 546.15 (W) IE 10"(OUT) = 546.15 (SE)



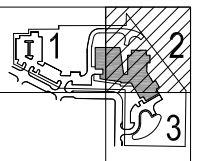
WEST LINN WILSONVILLE  
2755 SW Borland Road  
Tualatin, OR 97062  
(503) 673 7995



907 SW Stark Street Portland OR 97205 USA  
tel 503 226 6950 fax 503 273 9162  
www.dollon-ibigroup.com www.ibigroup.com



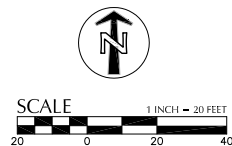
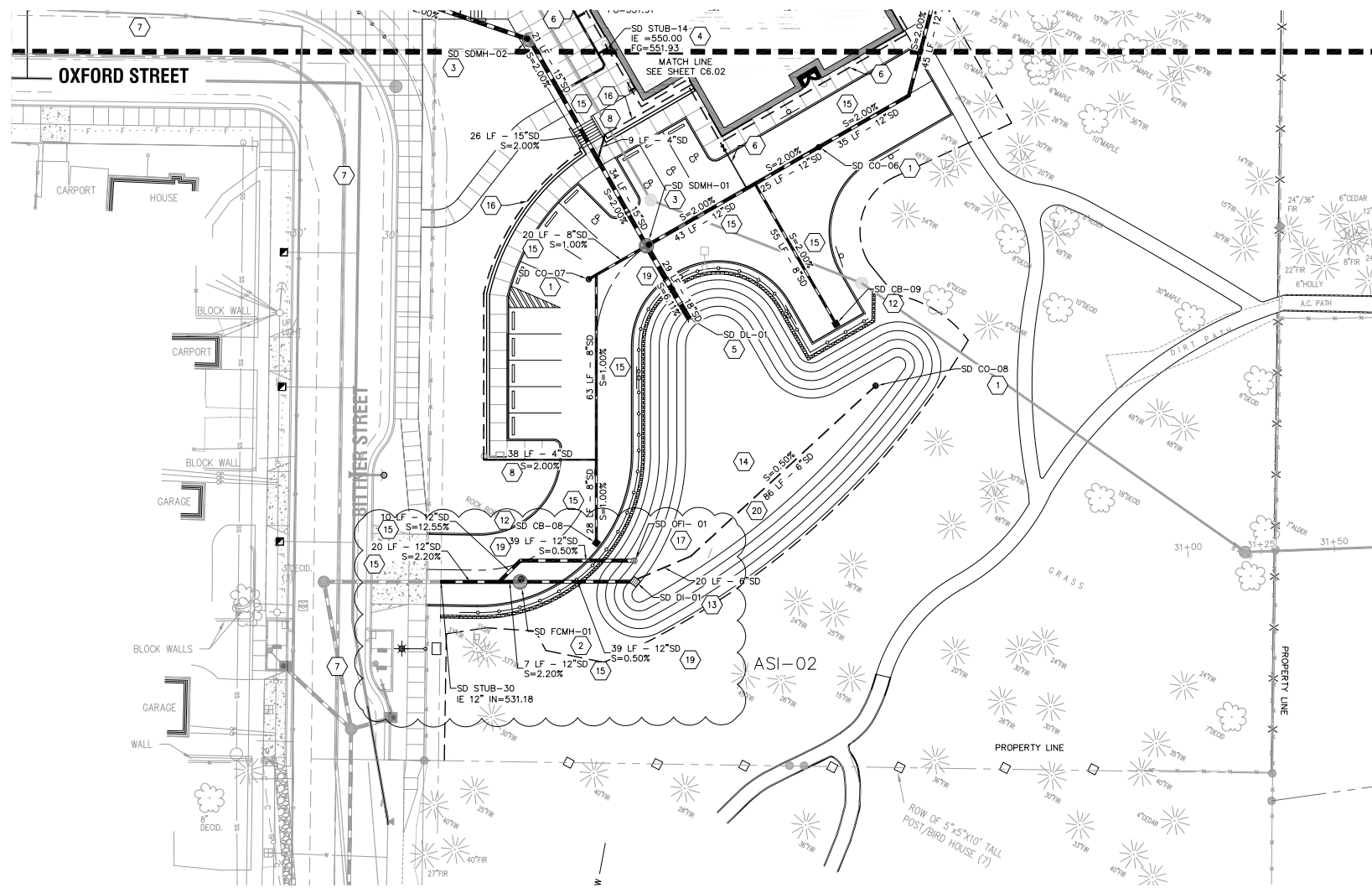
**SUNSET REVISIONING**  
West Linn Wilsonville School District  
2351 Oxford St, West Linn, OR 97068  
t: (503) 673-7988



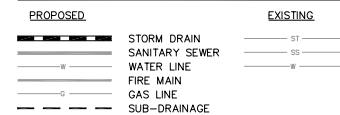
key plan

phase	Conformed Set
date	June 15, 2016
revisions	
project #	15015
<b>STORM PLAN NORTHEAST</b>	

**C6.02**



**PIPE LEGEND**

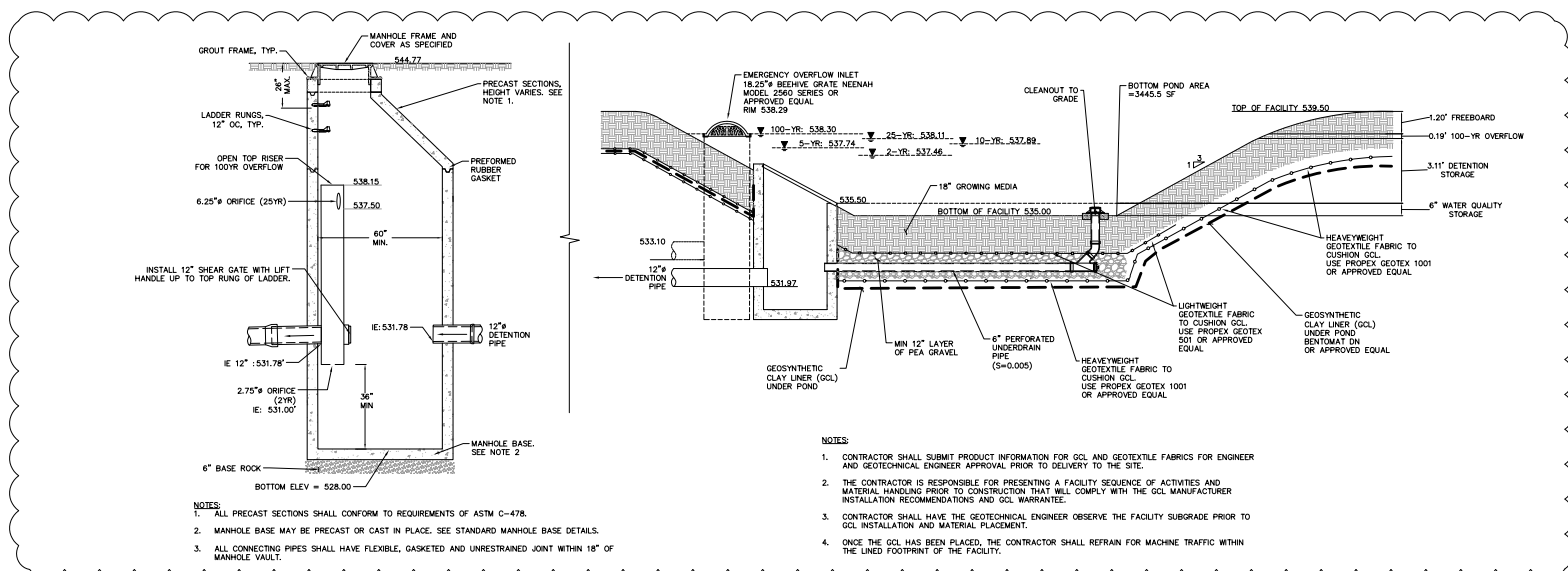


**STORM KEYNOTES**

- INSTALL STANDARD CLEANOUT.
- INSTALL FLOW CONTROL MANHOLE.
- INSTALL STANDARD 48" DIAMETER MANHOLE.
- CONNECT TO BUILDING ROOF DRAIN STUB WITH PVC LATERAL. LATERAL TO BE 6" DIAMETER UNLESS OTHERWISE NOTED ON PLANS. SLOPE AT A MINIMUM OF 2%. SEE PLUMBING PLANS FOR CONTINUATION. CONFIRM DOWNSPOUT LOCATION WITH ARCHITECTURAL AND PLUMBING PLANS PRIOR TO CONSTRUCTION.
- DAYLIGHT STORM PIPE.
- PROVIDE BUILDING FOOTING DRAIN SYSTEM AND CONNECT TO STORM DRAIN WITH SOLID WALL PVC PIPE. S=1% MINIMUM. SIZE TO MATCH SUB-DRAIN. INSTALL BACKWATER VALVE.
- SEE PUBLIC IMPROVEMENT (PI) PLANS FOR WORK IN RIGHT OF WAY (ROW).
- CONNECT RETAINING WALL SUB-SURFACE DRAIN TO STORM SYSTEM WITH 4" SOLID WALL PVC.
- PROVIDE TRENCH DRAIN.
- TRENCH DRAIN POINT OF CONNECTION. SEE STRUCTURE TABLE FOR LOCATION.
- PROVIDE AREA DRAIN (AD).
- PROVIDE CATCH BASIN.
- PROVIDE STANDARD DITCH INLET.
- CONSTRUCT STORMWATER TREATMENT/DETENTION FACILITY.
- PROVIDE PVC STORM DRAIN PIPE.
- PROVIDE 4" PVC PERF DRAIN IN 8" DRAIN ROCK ENVELOPE BEHIND RETAINING WALL.
- PROVIDE DETENTION OVERFLOW STRUCTURE.
- CONNECT TO EXTERIOR DOWNSPOUT AND PROVIDE CLEANOUT AT CONNECTION.
- PROVIDE DUCTILE IRON STORM DRAIN PIPE AT RETAINING WALL CROSSING.
- PROVIDE 8" PVC PERF DRAIN IN 12" DRAIN ROCK UNDER STORMWATER FACILITY.

**(SD) STRUCTURE TABLE**

STRUCTURE ID	NORTHING	EASTING	RIM ELEVATION	INVERT ELEVATIONS
AD-01	10120.56	10326.02	553.00	IE 8"(OUT) = 549.33 (W)
AD-02	10153.18	10326.02	553.00	IE 8"(OUT) = 549.33 (W)
AD-03	10185.81	10326.02	553.00	IE 8"(OUT) = 549.33 (W)
AD-04	10194.74	10339.59	553.27	IE 8"(OUT) = 549.33 (W)
AD-05	10225.15	10376.41	554.00	IE 8"(OUT) = 550.34 (S)
AD-06	10223.64	10392.06	554.00	IE 8"(OUT) = 550.33 (S)
CB-01	10184.61	9859.61	555.00	IE 8"(OUT) = 551.83 (S)
CB-02	10049.23	10013.05	551.55	IE 8"(OUT) = 548.55 (E)
CB-03	10036.04	10030.94	550.98	IE 8"(OUT) = 548.28 (N)
CB-04	10103.85	9893.48	555.09	IE 8"(OUT) = 551.28 (NE)
CB-05	10053.08	9992.58	551.00	IE 8"(OUT) = 549.00 (NE)
CB-06	10046.34	10067.33	552.30	IE 8"(OUT) = 547.95 (N)
CB-07	10178.40	10138.63	554.65	IE 8"(OUT) = 551.65 (E)
CB-08	9828.50	10374.46	544.34	IE 8"(OUT) = 539.84 (N)
CB-09	9903.30	10456.36	544.27	IE 8"(OUT) = 539.58 (NW)
CB-11	10216.99	10383.57	551.78	IE 10"(IN) = 546.91 (W) IE 10"(OUT) = 546.91 (E)
CB-12	10044.82	10156.79	552.85	IE 8"(OUT) = 545.74 (N)
CO-01	10124.97	9925.70	555.78	IE 10"(IN) = 550.16 (NW) IE 10"(OUT) = 550.16 (SE)
CO-02	10098.77	10323.02	553.94	IE 8"(OUT) = 549.61 (N)
CO-03	10216.99	10344.59	554.05	IE 8"(IN) = 547.66 (W) IE 8"(OUT) = 547.66 (E)
CO-04	10169.03	10443.93	551.98	IE 10"(IN) = 545.01 (N) IE 10"(OUT) = 545.01 (S)
CO-05	10083.34	10458.14	550.73	IE 10"(IN) = 543.22 (NW) IE 12"(OUT) = 543.05 (SE)
CO-06	9963.71	10450.52	545.92	IE 12"(IN) = 540.08 (NE) IE 12"(OUT) = 540.08 (SW)
CO-07	9918.59	10371.86	545.89	IE 8"(OUT) = 538.98 (NE)
CO-08	9882.18	10469.92	533.04	IE 6"(OUT) = 532.50 (SW)
DI-01	9815.25	10387.66	535.50	IE 12"(OUT) = 531.97 (W) IE 6"(IN) = 531.97 (NE)
DL-01	9905.14	10406.12	537.62	IE 18"(IN) = 536.00 (NW)
FCMH-01	9815.18	10348.42	544.77	IE 12"(IN) = 531.78 (E) IE 12"(OUT) = 531.78 (W)
OFI-01	9822.44	10387.47	538.30	IE 12"(OUT) = 533.10 (W)
SDMH-01	9929.96	10391.59	545.93	IE 12"(IN) = 538.73 (NE) IE 18"(OUT) = 537.76 (SE) IE 15"(IN) = 539.72 (NW) IE 8"(IN) = 538.73 (SW)
SDMH-02	10000.37	10351.68	551.55	IE 15"(IN) = 541.33 (W) IE 15"(OUT) = 541.33 (SE)
SDMH-03	10067.98	10154.50	554.13	IE 12"(IN) = 545.76 (W) IE 15"(OUT) = 545.51 (E) IE 10"(IN) = 545.51 (N) IE 8"(IN) = 545.51 (S)
SDMH-04	10252.95	10154.08	555.75	IE 8"(IN) = 549.04 (NE) IE 8"(OUT) = 549.04 (S)
SDMH-05	10069.79	10032.91	552.43	IE 10"(IN) = 547.75 (NW) IE 12"(OUT) = 547.58 (E) IE 8"(IN) = 547.60 (S)
SDMH-06	10216.99	10421.58	552.24	IE 10"(IN) = 546.15 (W) IE 10"(OUT) = 546.15 (SE)



**1 FLOW CONTROL MANHOLE & STORM FACILITY SECTION**

SCALE: NTS



WEST LINN WILSONVILLE  
2755 SW Borland Road  
Tualatin, OR 97062  
(503) 673 7995



Dull Olson Weekes - IBI Group  
Architects, Inc.

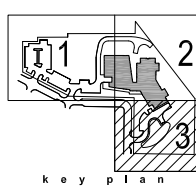
907 SW Stark Street Portland OR 97205 USA  
tel 503 226 6950 fax 503 273 9162  
www.dowolgroup.com www.ibigroup.com



111 SW Fifth Ave., Suite 2500  
Portland, OR 97204  
P: 503.227.3251  
F: 503.274.4881  
www.kpff.com



**SUNSET REVISIONING**  
West Linn Wilsonville School District  
2351 Oxford St, West Linn, OR 97068  
t: (503) 673-7988

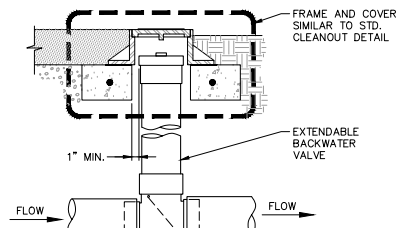


phase	Conformed Set
date	June 15, 2016
revisions	ASI-02 07.05.2016
project #	15015
STORM PLAN SOUTHEAST	

**C6.03**

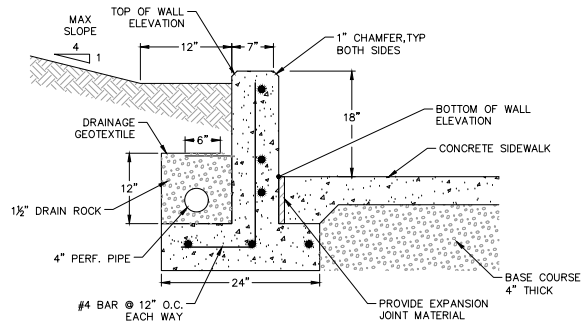
8/17/2015 8:19:12 AM N:\c\p\2015\315087-Sunset-Primary-School-FILE-TRANS\IN\20150810-REV\15-08-10 WLWV ARMS.dwg





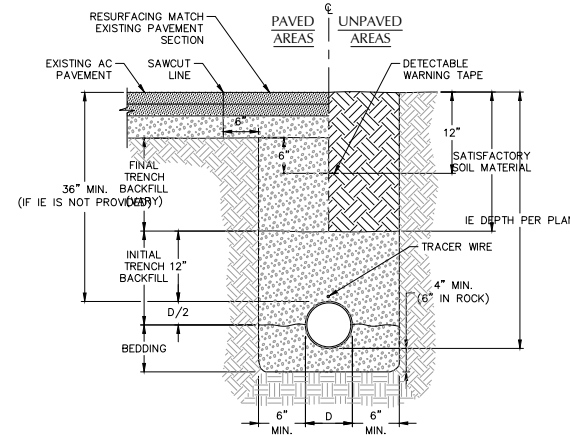
NOTES:  
1. EXTENDABLE BACKWATER VALVE TO BE MANUFACTURED BY CLEAN CHECK OR APPROVED EQUAL AND SHALL BE INSTALLED PER MANUFACTURER'S RECOMMENDATIONS.

8 EXTENDABLE BACKWATER VALVE  
SCALE: NTS

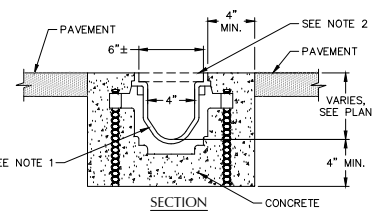


NOTES:  
1. PROVIDE SCORE AND CONTRACTION JOINTS PER DETAIL 11/C6.1.

9 CONCRETE RETAINING WALL  
SCALE: NTS

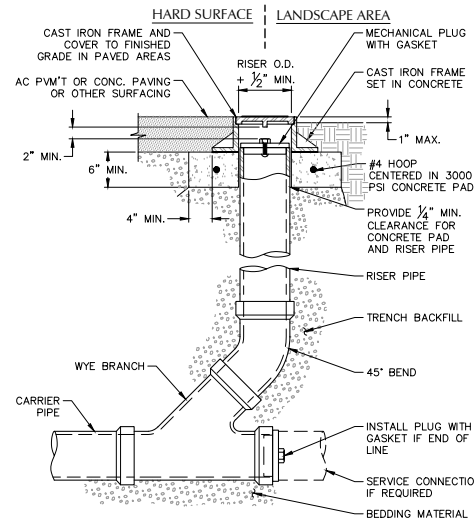


10 TYPICAL PIPE BEDDING AND BACKFILL  
SCALE: NTS



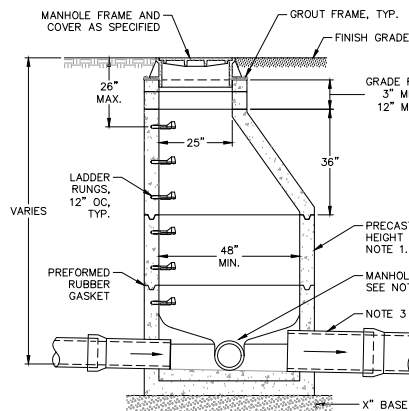
NOTES:  
1. TRENCH DRAIN SHALL BE PRE-SLOPED 6" WIDE ZURN TRENCH DRAIN OR APPROVED EQUAL.  
2. TRENCH DRAIN GRATE SHALL BE LOCKABLE HEAVY DUTY ADA TRENCH GRATE - CLASS C.  
3. TRENCH SYSTEM SHALL BE INSTALLED PER MANUFACTURER'S INSTRUCTIONS.  
4. PROVIDE BOTTOM OUTLET AT LOWPOINT PER MANUFACTURER DETAILS.

11 TRENCH DRAIN - 6 INCH WIDE  
SCALE: NTS



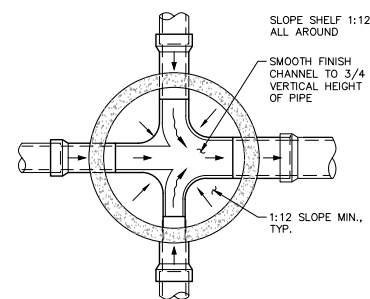
NOTES:  
1. CAST IRON FRAME AND COVER SHALL MEET H-20 LOAD REQUIREMENT.  
2. FOR CARRIER PIPE SIZE 6"Ø AND LESS, PROVIDE RISER PIPE SIZE TO MATCH CARRIER PIPE.  
3. FOR CARRIER PIPE SIZE 8"Ø AND LARGER, RISER PIPE SHALL BE 6"Ø.  
4. RISER PIPE MATERIAL TO MATCH CARRIER PIPE MATERIAL.

5 STANDARD CLEANOUT (COTG)  
SCALE: NTS



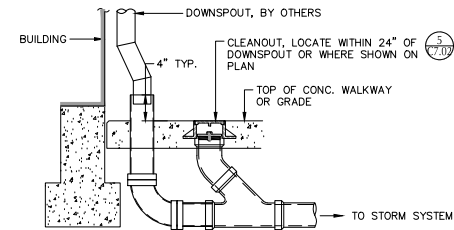
NOTES:  
1. ALL PRECAST SECTIONS SHALL CONFORM TO REQUIREMENTS OF ASTM C-478.  
2. MANHOLE BASE MAY BE PRECAST OR CAST IN PLACE. SEE STANDARD MANHOLE BASE DETAILS, 7/C7.02.  
3. ALL CONNECTING PIPES SHALL HAVE FLEXIBLE, GASKETED AND UNRESTRAINED JOINT WITHIN 18" OF MANHOLE VAULT.

6 STANDARD MANHOLE  
SCALE: NTS

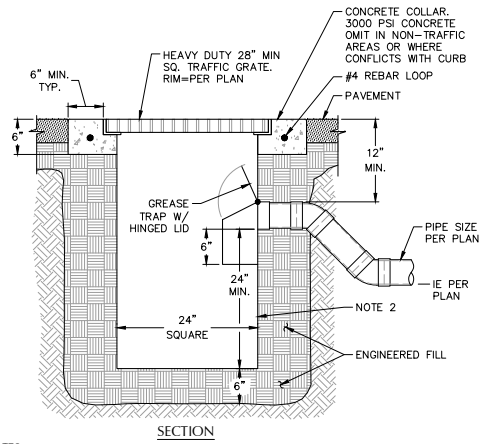


NOTES:  
1. BASED MAY BE PRECAST OR CAST IN PLACE.  
2. ALL PRECAST SECTIONS SHALL CONFORM TO REQUIREMENTS OF ASTM C-478.  
3. CONCRETE SHALL BE COMMERCIAL GRADE.  
4. CHANNELS SHALL BE CONSTRUCTED TO PROVIDE SMOOTH SLOPES AND RADIUS TO OUTLET PIPE.  
5. EXTEND PIPE INTO MANHOLE AND GROUT SMOOTH. PIPE(S) MAY EXTEND 2" MAX BEYOND THE INTERIOR MANHOLE WALL.

7 MANHOLE BASE - STANDARD  
SCALE: NTS

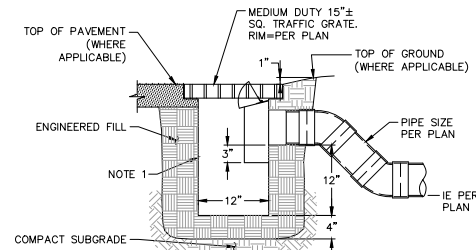


1 STANDARD DOWNSPOUT  
SCALE: NTS



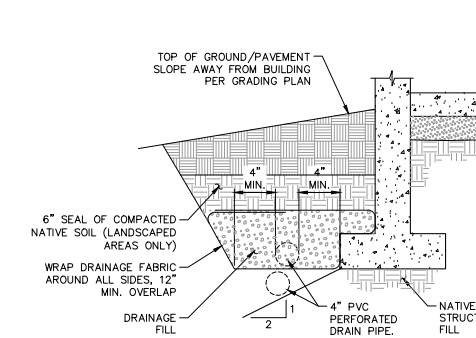
NOTES:  
1. CONTRACTOR TO WIDEN EXCAVATION AS REQUIRED TO OBTAIN COMPACTION WITH CONTRACTORS COMPACTION EQUIPMENT.  
2. 1/4" STEEL PLATE, BITUMINOUS COATED, AS MANUFACTURED BY GIBSON STEEL BASINS OR APPROVED EQUAL.

2 TRAPPED CATCH BASIN  
SCALE: NTS



NOTE:  
1. TO GAGE STEEL PLATE, BITUMINOUS COATED, AS MANUFACTURED BY GIBSON STEEL BASINS OR APPROVED EQUAL.

3 TRAPPED AREA DRAIN  
SCALE: NTS



NOTES:  
1. LAY PERFORATED DRAIN PIPE ON MIN. 0.5% GRADIENT, WIDENING EXCAVATION AS REQUIRED. MAINTAIN PIPE ABOVE 2:1 SLOPE AS SHOWN.  
2. CONNECT TO FOUNDATION DRAIN STUBOUT SHOWN ON PLANS.

4 PERIMETER FOUNDATION DRAIN  
SCALE: NTS



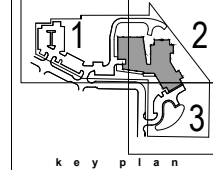
WEST LINN WILSONVILLE  
2755 SW Borland Road  
Tualatin, OR 97062  
(503) 673 7995



Dull Olson Weekes - IBI Group  
Architects, Inc.  
907 SW Stark Street Portland, OR 97205 USA  
tel 503 228 8950 fax 503 273 9192  
www.dowa-ibigroup.com www.ibigroup.com

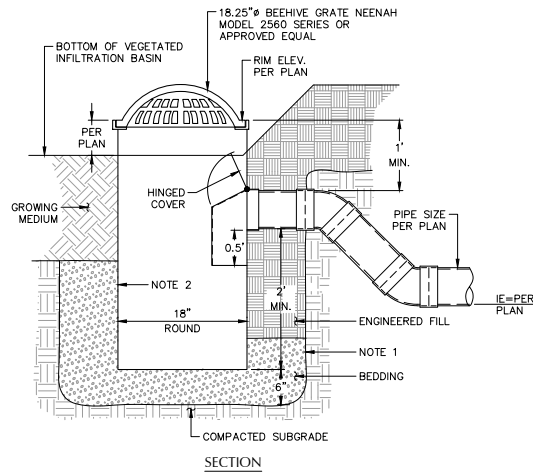


SUNSET REVISIONING  
West Linn Wilsonville School District  
2351 Oxford St., West Linn, OR 97068  
t: (503) 673-7988



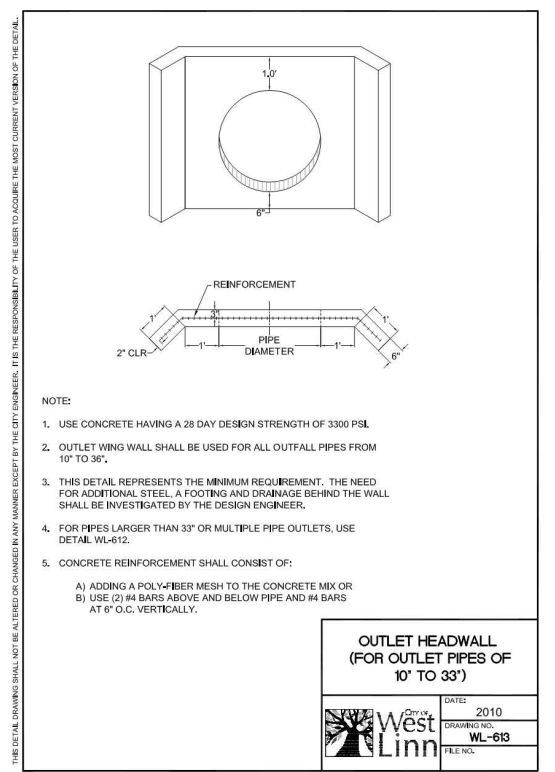
phase	Conformed Set
date	June 15, 2016
revisions	
project #	15015

CIVIL DETAILS  
**C7.02**



- NOTES:
- CONTRACTOR TO WIDEN EXCAVATION AS REQUIRED TO OBTAIN COMPACTION WITH CONTRACTORS COMPACTION EQUIPMENT.
  - 10 GA STEEL PLATE, BITUMINOUS COATED BASIN AS MANUFACTURED BY GIBSON STEEL, GRATEMASTER OR APPROVED EQUAL.

7 OVERFLOW INLET - TYPE 2  
SCALE: N.T.S.

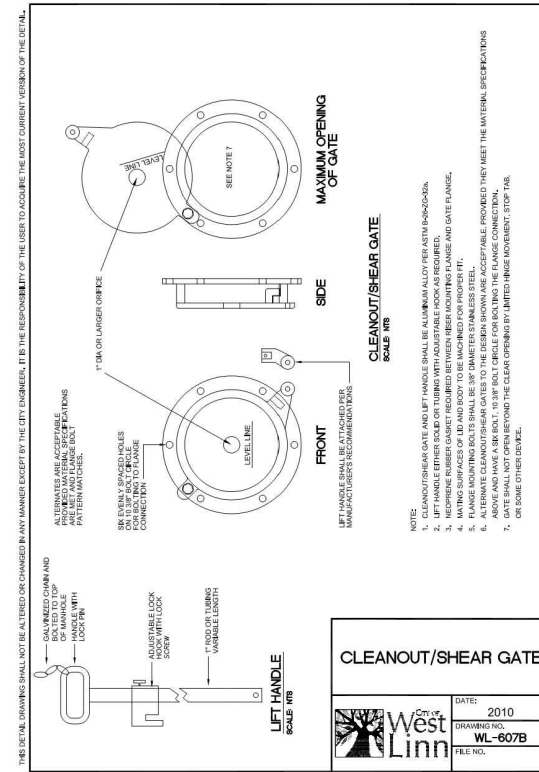


- NOTE:
- USE CONCRETE HAVING A 28 DAY DESIGN STRENGTH OF 3300 PSF.
  - OUTLET WING WALL SHALL BE USED FOR ALL OUTFALL PIPES FROM 10" TO 36".
  - THIS DETAIL REPRESENTS THE MINIMUM REQUIREMENT. THE NEED FOR ADDITIONAL STEEL, A FOOTING AND DRAINAGE BEHIND THE WALL SHALL BE INVESTIGATED BY THE DESIGN ENGINEER.
  - FOR PIPES LARGER THAN 33" OR MULTIPLE PIPE OUTLETS, USE DETAIL WL-612.
  - CONCRETE REINFORCEMENT SHALL CONSIST OF:
    - ADDING A POLY-FIBER MESH TO THE CONCRETE MIX OR
    - USE (2) #4 BARS ABOVE AND BELOW PIPE AND #4 BARS AT 6" O.C. VERTICALLY.

**OUTLET HEADWALL (FOR OUTLET PIPES OF 10" TO 33")**

DATE: 2010  
DRAWING NO.: WL-613  
FILE NO.:

5 HEADWALL  
SCALE: N.T.S.

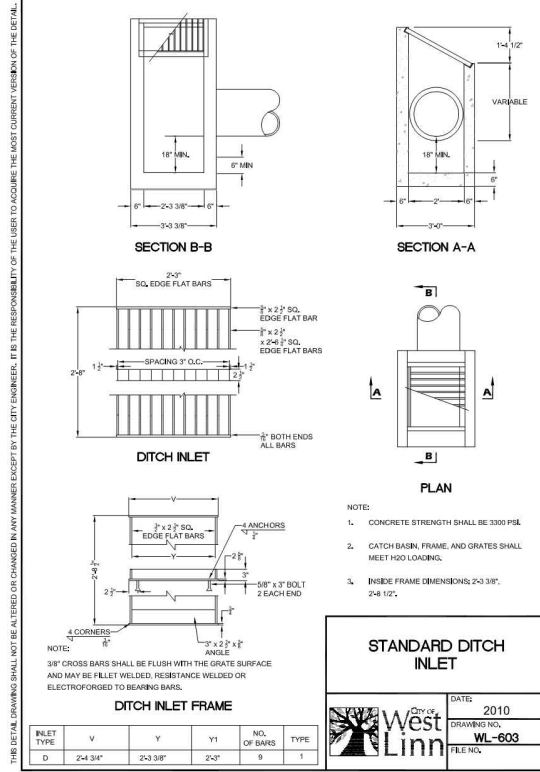


- NOTE:
- CLEANOUT/SHEAR GATE SHALL BE MANUFACTURED BY A MANUFACTURER WHO SHALL BE APPROVED BY THE CITY ENGINEER.
  - MANUFACTURER SHALL PROVIDE ALL DIMENSIONS AND MATERIAL SPECIFICATIONS.
  - RESISTANCE TO BE WELDED OR ELECTROFORGED TO BEARING BARS.
  - MANUFACTURER SHALL PROVIDE ALL DIMENSIONS AND MATERIAL SPECIFICATIONS.
  - MANUFACTURER SHALL PROVIDE ALL DIMENSIONS AND MATERIAL SPECIFICATIONS.
  - MANUFACTURER SHALL PROVIDE ALL DIMENSIONS AND MATERIAL SPECIFICATIONS.
  - MANUFACTURER SHALL PROVIDE ALL DIMENSIONS AND MATERIAL SPECIFICATIONS.
  - MANUFACTURER SHALL PROVIDE ALL DIMENSIONS AND MATERIAL SPECIFICATIONS.

**CLEANOUT/SHEAR GATE**

DATE: 2010  
DRAWING NO.: WL-607B  
FILE NO.:

3 CLEANOUT/SHEAR GATE  
SCALE: N.T.S.

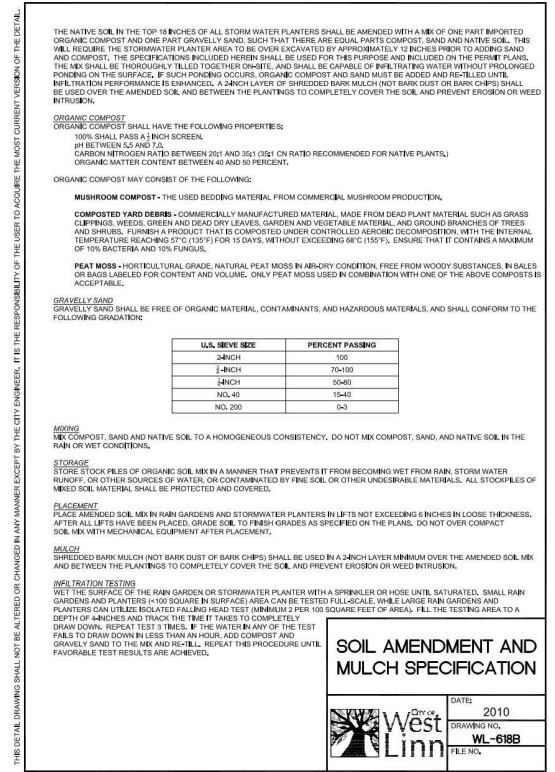


- NOTE:
- CONCRETE STRENGTH SHALL BE 3300 PSI.
  - CATCH BASIN, FRAME, AND GRATES SHALL MEET H20 LOADING.
  - INSIDE FRAME DIMENSIONS 24" X 30", 24" X 12".

**STANDARD DITCH INLET**

DATE: 2010  
DRAWING NO.: WL-603  
FILE NO.:

1 STANDARD DITCH INLET TYPE 2  
SCALE: N.T.S.



THE NATIVE SOIL IN THE TOP 18 INCHES OF ALL STORM WATER PLANTERS SHALL BE AMENDED WITH A MIX OF ONE PART IMPORTED ORGANIC COMPOST AND ONE PART GRAVELLY SAND, SUCH THAT THERE ARE EQUAL PARTS COMPOST, SAND AND NATIVE SOIL. THIS MIX SHALL BE THOROUGHLY MIXED TOGETHER AND SHALL BE APPLIED TO THE PLANTER AREA BY APPROXIMATELY 1/8 INCHES PRIOR TO ADDING SAND AND COMPOST. THE SPECIFICATIONS INCLUDED HEREIN SHALL BE USED FOR THIS PURPOSE AND INCLUDED ON THE PERMIT PLANS. THE MIX SHALL BE THOROUGHLY MIXED TOGETHER AND SHALL BE APPLIED TO THE PLANTER AREA BY APPROXIMATELY 1/8 INCHES PRIOR TO ADDING SAND AND COMPOST. IF SUCH PONDING OCCURS, ORGANIC COMPOST AND SAND MUST BE ADDED AND RE-TILLED UNTIL INFILTRATION PERFORMANCE IS ENHANCED. A LAYER OF SHREDDED BARK MULCH (NOT BARK DUST OR BARK CHIPS) SHALL BE USED OVER THE AMENDED SOIL, AND BETWEEN THE PLANTINGS TO COMPLETELY COVER THE SOIL AND PREVENT EROSION OR WEED INTRUSION.

**ORGANIC COMPOST**  
ORGANIC COMPOST SHALL HAVE THE FOLLOWING PROPERTIES:  
PH BE BETWEEN 5.5 AND 7.5  
CARBON NITROGEN RATIO BETWEEN 20:1 AND 35:1 (ON DRY OR RATIO RECOMMENDED FOR NATIVE PLANTS)  
ORGANIC MATTER CONTENT BETWEEN 40 AND 50 PERCENT.

ORGANIC COMPOST MAY CONSIST OF THE FOLLOWING:  
**MUSHROOM COMPOST** - THE USED BEDDING MATERIAL FROM COMMERCIAL MUSHROOM PRODUCTION.  
**COMPOSTED YARD DEBRIS** - COMMERCIALLY MANUFACTURED MATERIAL, MADE FROM DEAD PLANT MATERIAL SUCH AS GRASS CLIPPINGS, WEEDS, GREEN AND DEAD DRY LEAVES, GARDEN AND VEGETABLE MATERIAL, AND GROUND BRANCHES OF TREES AND SHRUBS. FURNISH A PRODUCT THAT IS COMPOSTED UNDER CONTROLLED AEROBIC CONDITIONS, WITH THE INTERNAL TEMPERATURE REACHING 57°C (135°F) FOR 15 DAYS, WITHOUT EXCEEDING 65°C (155°F), ENSURE THAT IT CONTAINS A MAXIMUM OF 10% BACTERIA AND 10% FUNGI.  
**PEAT MOSS** - HORTICULTURAL GRADE, NATURAL PEAT MOSS IN AERATED CONDITION, FREE FROM WOODY SUBSTANCES, IN BALES OR BAGS LABELED FOR CONTENT AND VOLUME. ONLY PEAT MOSS USED IN COMBINATION WITH ONE OF THE ABOVE COMPOSTS IS ACCEPTABLE.

**GRAVELLY SAND**  
GRAVELLY SAND SHALL BE FREE OF ORGANIC MATERIAL, CONTAMINANTS, AND HAZARDOUS MATERIALS, AND SHALL CONFORM TO THE FOLLOWING GRADATION:

U.S. SIEVE SIZE	PERCENT PASSING
3/8 INCH	100
1/2 INCH	70-90
3/4 INCH	50-80
NO. 40	15-40
NO. 200	5-3

**MIX**  
MIX COMPOST, SAND AND NATIVE SOIL TO A HOMOGENEOUS CONSISTENCY. DO NOT MIX COMPOST, SAND, AND NATIVE SOIL IN THE RAIN OR WET CONDITIONS.

**STORAGE**  
STORE STOCK PILES OF ORGANIC SOIL MIX IN A MANNER THAT PREVENTS IT FROM BECOMING WET FROM RAIN, STORM WATER RUNOFF, OR OTHER SOURCES OF WATER, OR CONTAMINATED BY FINE SOIL OR OTHER UNDESIRABLE MATERIALS. ALL STOCKPILES OF MIXED SOIL MATERIAL SHALL BE PROTECTED AND COVERED.

**PLACEMENT**  
PLACE AMENDED SOIL MIX IN RAIN GARDENS AND STORMWATER PLANTERS IN LIFT NOT EXCEEDING 8 INCHES IN THICKNESS. AFTER ALL LIFTS HAVE BEEN PLACED, GRADE SOIL TO FINISH GRADES AS SPECIFIED ON THE PLANS. DO NOT OVER COMPACT SOIL MIX WITH MECHANICAL EQUIPMENT AFTER PLACEMENT.

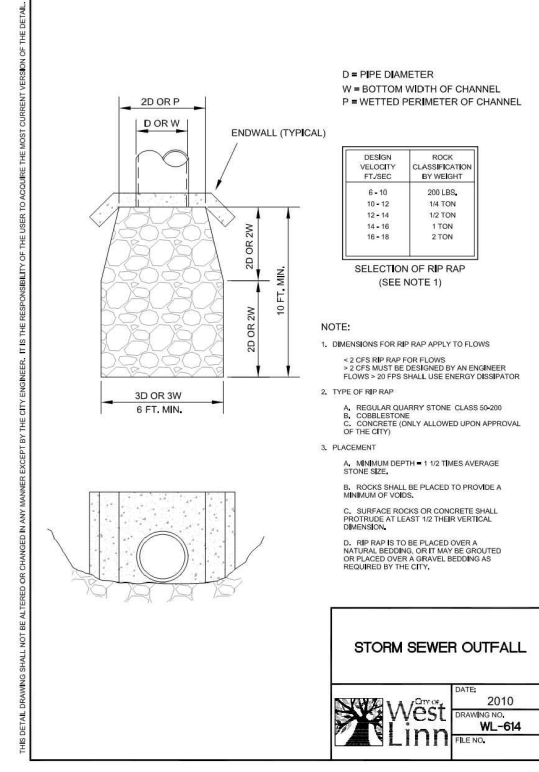
**MULCH**  
SHREDDED BARK MULCH (NOT BARK DUST OR BARK CHIPS) SHALL BE USED IN A LAYER LAYER (MINIMUM OVER THE AMENDED SOIL MIX AND BETWEEN THE PLANTINGS TO COMPLETELY COVER THE SOIL AND PREVENT EROSION OR WEED INTRUSION).

**INFILTRATION TESTING**  
WET THE SURFACE OF THE RAIN GARDEN OR STORMWATER PLANTER WITH A SPRINKLER OR HOSE UNTIL SATURATED. SMALL RAIN GARDENS AND PLANTERS <100 SQUARE IN SURFACE AREA CAN BE TESTED FULL SCALE. WHILE LARGE RAIN GARDENS AND PLANTERS CAN UTILIZE ISOLATED FALLING HEAD TEST (MINIMUM 2 PER 100 SQUARE FEET OF AREA). FILL THE TESTING AREA TO A DEPTH OF 4 INCHES AND TRACK THE TRITEL TRACES TO COMPLETELY DRAW DOWN. REPEAT TEST 3 TIMES. IF THE WATER IN ANY OF THE TEST PALS TO DRAW DOWN IN LESS THAN AN HOUR, ADD COMPOST AND GRAVELLY SAND TO THE MIX AND RE-TILL. REPEAT THIS PROCEDURE UNTIL FAVORABLE TEST RESULTS ARE ACHIEVED.

**SOIL AMENDMENT AND MULCH SPECIFICATION**

DATE: 2010  
DRAWING NO.: WL-618B  
FILE NO.:

6 SOIL AMENDMENT AND MULCH SPECIFICATION  
SCALE: N.T.S.



D = PIPE DIAMETER  
W = BOTTOM WIDTH OF CHANNEL  
P = WETTED PERIMETER OF CHANNEL

DESIGN VELOCITY FT./SEC.	ROCK CLASSIFICATION BY WEIGHT
6 - 10	200 LBS.
10 - 12	14 TON
12 - 14	1/2 TON
14 - 16	1 TON
16 - 18	2 TON

SELECTION OF RIP RAP (SEE NOTE 1)

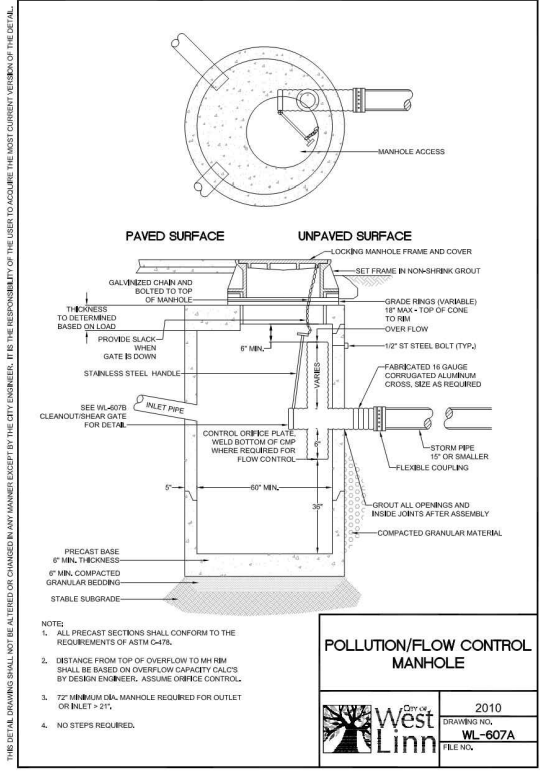
NOTE:

- DIMENSIONS FOR RIP RAP APPLY TO FLOWS
- 2 CFS RIP RAP FOR FLOWS < 2 CFS MUST BE DESIGNED BY AN ENGINEER FLOWS > 20 FPS SHALL USE ENERGY DISSIPATOR
- TYPE OF RIP RAP
  - REGULAR QUARRY STONE CLASS 50009
  - CONCRETE
  - CONCRETE (ONLY ALLOWED UPON APPROVAL OF THE CITY)
- PLACEMENT
  - MINIMUM DEPTH = 1 1/2 TIMES AVERAGE STONE SIZE
  - ROCKS SHALL BE PLACED TO PROVIDE A MINIMUM OF VOIDS
  - SURFACE ROCKS OR CONCRETE SHALL PROTRUDE AT LEAST 1/2 THEIR VERTICAL DIMENSION
  - RIP RAP IS TO BE PLACED OVER NATURAL BEDROCK. GRIET MAY BE GROUTED OR PLACED OVER A GRAVEL BEDDING AS REQUIRED BY THE CITY.

**STORM SEWER OUTFALL**

DATE: 2010  
DRAWING NO.: WL-614  
FILE NO.:

4 STORM SEWER OUTFALL  
SCALE: N.T.S.



**POLLUTION/FLOW CONTROL MANHOLE**

DATE: 2010  
DRAWING NO.: WL-607A  
FILE NO.:

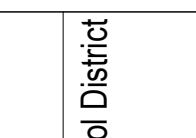
2 POLLUTION/FLOW CONTROL MANHOLE  
SCALE: N.T.S.

- NOTES:
- SEE DETAIL 1/C6.03 FOR SPECIFIC ELEVATION AND ORIFICE SIZE DETAILS IN FLOW CONTROL MANHOLE.

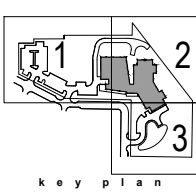


WEST LINN WILSONVILLE  
2755 SW Borland Road  
Tualatin, OR 97062  
(503) 673 7995

**dowa** | **IBI**  
Dull Olson Weekes - IBI Group  
Architects, Inc.  
907 SW Stark Street Portland, OR 97205 USA  
tel 503 226 6950 fax 503 273 9192  
www.dowa-ibigroup.com www.ibigroup.com



**SUNSET REVISIONING**  
West Linn Wilsonville School District  
2351 Oxford St., West Linn, OR 97068  
t: (503) 673-7988



phase	Conformed Set
date	June 15, 2016
revisions	ASI-02 07.05.2016
project #	15015

DT  
**C7.05**

## **Appendix B**

- Hydrologic Analysis
- Geosynthetic Clay Liner Specifications



**Calculation Spreadsheet:  
Summary  
Appendix B**

Sunset Primary School  
KPFF Job #: 315087  
Designer: AC  
Check Engineer: MJ

**ASSUMPTIONS**

SBUH Method Assumptions:

(used for water quality and detention sizing)

2-year Storm Event =	<b>2.5</b>	in/24-hours	
5-year Storm Event =	<b>3.0</b>	in/24-hours	Per 2006 City of West Linn Surface Water Management Plan
10-year Storm Event=	<b>3.4</b>	in/24-hours	
25-year Storm Event=	<b>3.9</b>	in/24-hours	

Roughness Coefficient = **0.013**

Curve Number (CN):

Impervious Area =	<b>98</b>	Impervious	Per Technical Release 55
Pervious Area =	<b>74</b>	Type C Soils: Good	Table 2-2a
Pre Developed Area =	<b>76</b>	Type C Soils: Fair	Table 2-2c

Rational Method Assumptions:

(used for conveyance pipe sizing)

Rainfall Intensity ( I )

25-year Storm Event =	<b>3.9</b>	in/hr	Per ODOT Hydraulics Manual, Ch 7, Appendix A
-----------------------	------------	-------	---

Runoff Coefficient ( C )

Impervious Area =	<b>0.9</b>	
Pervious Area =	<b>0.25</b>	Per ODOT Hydraulics Manual, Ch 7, Appendix F



**Calculation Spreadsheet:  
Summary  
Appendix B**

Sunset Primary School  
KPFF Job #: 315087  
Designer: AC  
Check Engineer: MJ

**Detention Facility Design**

Bottom of Detention Facility modeled at bottom elevation = 0.00-ft  
Facility is a Flat Bottom amoeba shape with 3:1 side slopes

Pre Developed Q		Post Developed Q		Undeveloped Q	Facility Max Depth (ft)
2yr	0.40	2yr	0.28	0.11	2.46
5yr	0.70	5yr	0.47	0.20	2.74
10yr	0.97	10yr	0.66	0.27	2.89
25yr	1.35	25yr	0.94	0.38	3.11
100yr	1.84	100yr			3.30

**Flow Control Design**

Bottom of Detention Facility modeled at bottom elevation = 0.00-ft  
Facility is a Flat Bottom amoeba shape with 3:1 side slopes

	Description	IE (ft)	Size (in)	IE Crown (ft)
Orifice 1	Bottom of Tee	-4	2.625	
Orifice 2	On Side of Tee	2.5	6.25	3.02
Orifice 3	Overflow on Top of Tee	3.15	12	

**Facility Storage Volume  
(Depth 0ft = Elev 535')**

Storage curve data  
Storage data type:

	Depth (ft)	Area (ft <sup>2</sup> )	Volume (ft <sup>3</sup> )
1	0	3445	0.000
2	1	4423	3934.00
3	2	5458	8874.50
4	3	6549	14878.00
5	4	7697	22001.00
6			

# Appendix B

## Pre Developed Condition Properties

Subbasins

General  
Subbasin ID: BASIN1

Connectivity  
Rain gage: Rain Gage-01  
Outlet node: PRE

Delete  
Show  
Report

Description:

Physical Properties SCS TR-55 TOC

Physical properties

Area:	273556.0000	ft <sup>2</sup>	<input type="checkbox"/> Time of concentration:	39.08	min
Equivalent width:	500	ft	Weighted curve number:	76	
Average slope:	0.5	%	Manning's roughness:	0.015	
Impervious area			Curve number:	98	
Area:	0	%			
No depression:	25	%			
Pervious area			Manning's roughness:	0.1	
Curve number:	76				

Basin area of 273556 sf  
assumed all pervious  
with CN = 76

# Appendix B

## Pre Developed Time of Concentration

SCS TR-55 Time of Concentration Computations Report

=====

### Sheet Flow Equation

-----

$$T_c = (0.007 * ((n * L_f)^{0.8})) / ((P^{0.5}) * (S_f^{0.4}))$$

Where:

Tc = Time of Concentration (hrs)  
n = Manning's Roughness  
Lf = Flow Length (ft)  
P = 2 yr, 24 hr Rainfall (inches)  
Sf = Slope (ft/ft)

### Shallow Concentrated Flow Equation

-----

V = 16.1345 \* (Sf<sup>0.5</sup>) (unpaved surface)  
V = 20.3282 \* (Sf<sup>0.5</sup>) (paved surface)  
V = 15.0 \* (Sf<sup>0.5</sup>) (grassed waterway surface)  
V = 10.0 \* (Sf<sup>0.5</sup>) (nearly bare & untilled surface)  
V = 9.0 \* (Sf<sup>0.5</sup>) (cultivated straight rows surface)  
V = 7.0 \* (Sf<sup>0.5</sup>) (short grass pasture surface)  
V = 5.0 \* (Sf<sup>0.5</sup>) (woodland surface)  
V = 2.5 \* (Sf<sup>0.5</sup>) (forest w/heavy litter surface)  
Tc = (Lf / V) / (3600 sec/hr)

Where:

Tc = Time of Concentration (hrs)  
Lf = Flow Length (ft)  
V = Velocity (ft/sec)  
Sf = Slope (ft/ft)

### Channel Flow Equation

-----

V = (1.49 \* (R<sup>(2/3)</sup>) \* (Sf<sup>0.5</sup>)) / n  
R = Aq / Wp  
Tc = (Lf / V) / (3600 sec/hr)

Where:

Tc = Time of Concentration (hrs)  
Lf = Flow Length (ft)

# Appendix B

## Pre Developed Time of Concentration

R = Hydraulic Radius (ft)  
Aq = Flow Area (ft<sup>2</sup>)  
Wp = Wetted Perimeter (ft)  
V = Velocity (ft/sec)  
Sf = Slope (ft/ft)  
n = Manning's Roughness

=====  
Subbasin BASIN1  
=====

### Sheet Flow Computations

-----

-	Subarea A
Manning's Roughness:	0.4
Flow Length (ft):	300
Slope (%):	5.67
2 yr, 24 hr Rainfall (in):	2.65
Velocity (ft/sec):	0.13
Computed Flow Time (minutes):	37.46

### Shallow Concentrated Flow Computations

-----

-	Subarea A
Flow Length (ft):	163
Slope (%):	5.67
Surface Type:	Grass pasture
Velocity (ft/sec):	1.67
Computed Flow Time (minutes):	1.63

=====  
Total TOC (minutes): 39.08  
=====



# Appendix B

## Undeveloped Time of Concentration

SCS TR-55 Time of Concentration Computations Report

Sheet Flow Equation

$$T_c = (0.007 * ((n * L_f)^{0.8})) / ((P^{0.5}) * (S_f^{0.4}))$$

Where:

Tc = Time of Concentration (hrs)  
n = Manning's Roughness  
Lf = Flow Length (ft)  
P = 2 yr, 24 hr Rainfall (inches)  
Sf = Slope (ft/ft)

Shallow Concentrated Flow Equation

V = 16.1345 \* (Sf<sup>0.5</sup>) (unpaved surface)  
V = 20.3282 \* (Sf<sup>0.5</sup>) (paved surface)  
V = 15.0 \* (Sf<sup>0.5</sup>) (grassed waterway surface)  
V = 10.0 \* (Sf<sup>0.5</sup>) (nearly bare & untilled surface)  
V = 9.0 \* (Sf<sup>0.5</sup>) (cultivated straight rows surface)  
V = 7.0 \* (Sf<sup>0.5</sup>) (short grass pasture surface)  
V = 5.0 \* (Sf<sup>0.5</sup>) (woodland surface)  
V = 2.5 \* (Sf<sup>0.5</sup>) (forest w/heavy litter surface)  
Tc = (Lf / V) / (3600 sec/hr)

Where:

Tc = Time of Concentration (hrs)  
Lf = Flow Length (ft)  
V = Velocity (ft/sec)  
Sf = Slope (ft/ft)

Channel Flow Equation

V = (1.49 \* (R<sup>(2/3)</sup>) \* (Sf<sup>0.5</sup>)) / n  
R = Aq / Wp  
Tc = (Lf / V) / (3600 sec/hr)

Where:

Tc = Time of Concentration (hrs)  
Lf = Flow Length (ft)

# Appendix B

## Undeveloped Time of Concentration

R = Hydraulic Radius (ft)  
Aq = Flow Area (ft<sup>2</sup>)  
Wp = Wetted Perimeter (ft)  
V = Velocity (ft/sec)  
Sf = Slope (ft/ft)  
n = Manning's Roughness

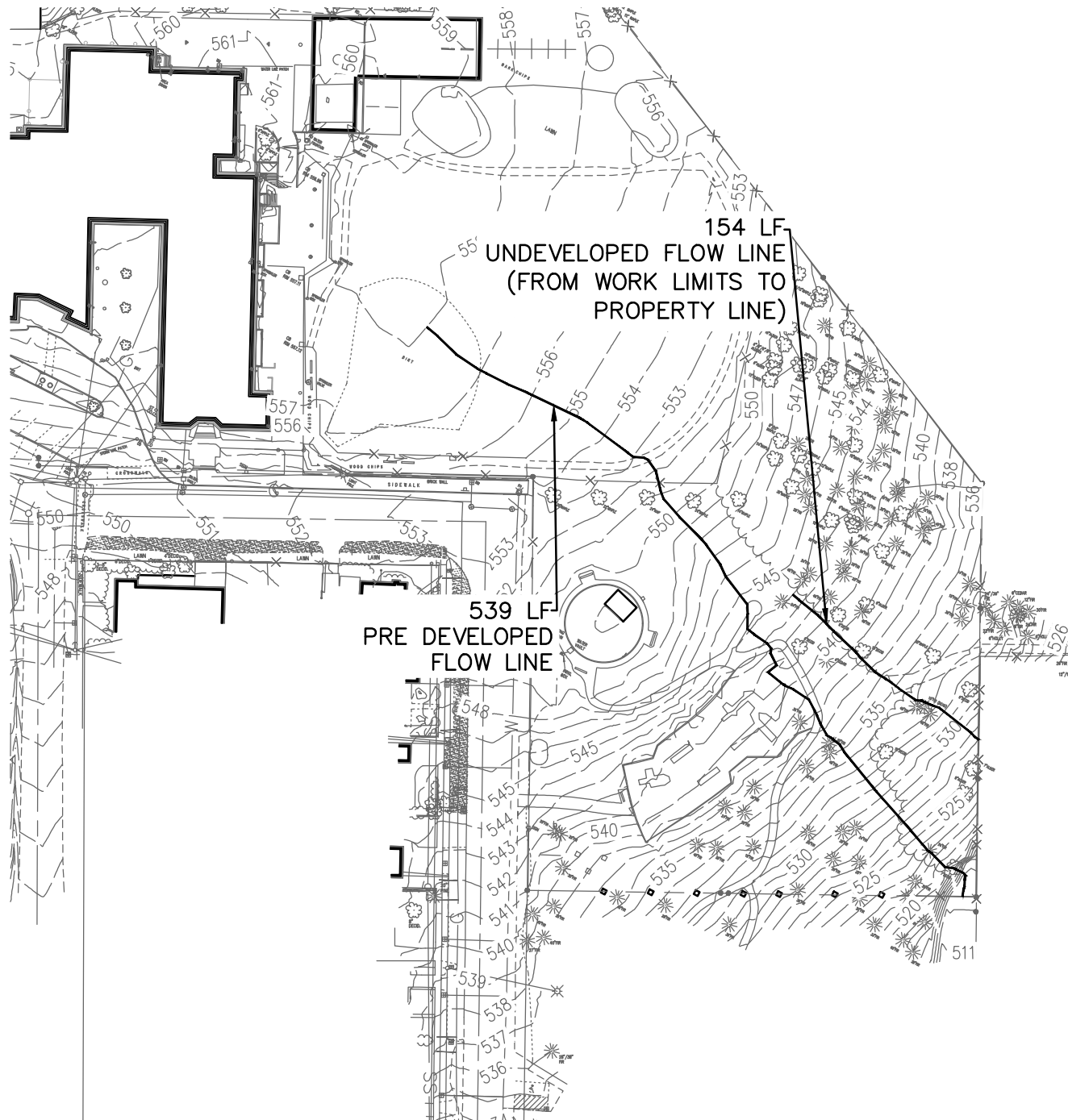
=====  
Subbasin Undeveloped  
=====

Sheet Flow Computations  
-----

-	Subarea A
Manning's Roughness:	0.4
Flow Length (ft):	154
Slope (%):	11
2 yr, 24 hr Rainfall (in):	2.65
Velocity (ft/sec):	0.15
Computed Flow Time (minutes):	16.86

=====  
Total TOC (minutes): 16.86  
=====

Proposed Developed site assumed  
minimum time of concentration of 5  
minutes for conservative design

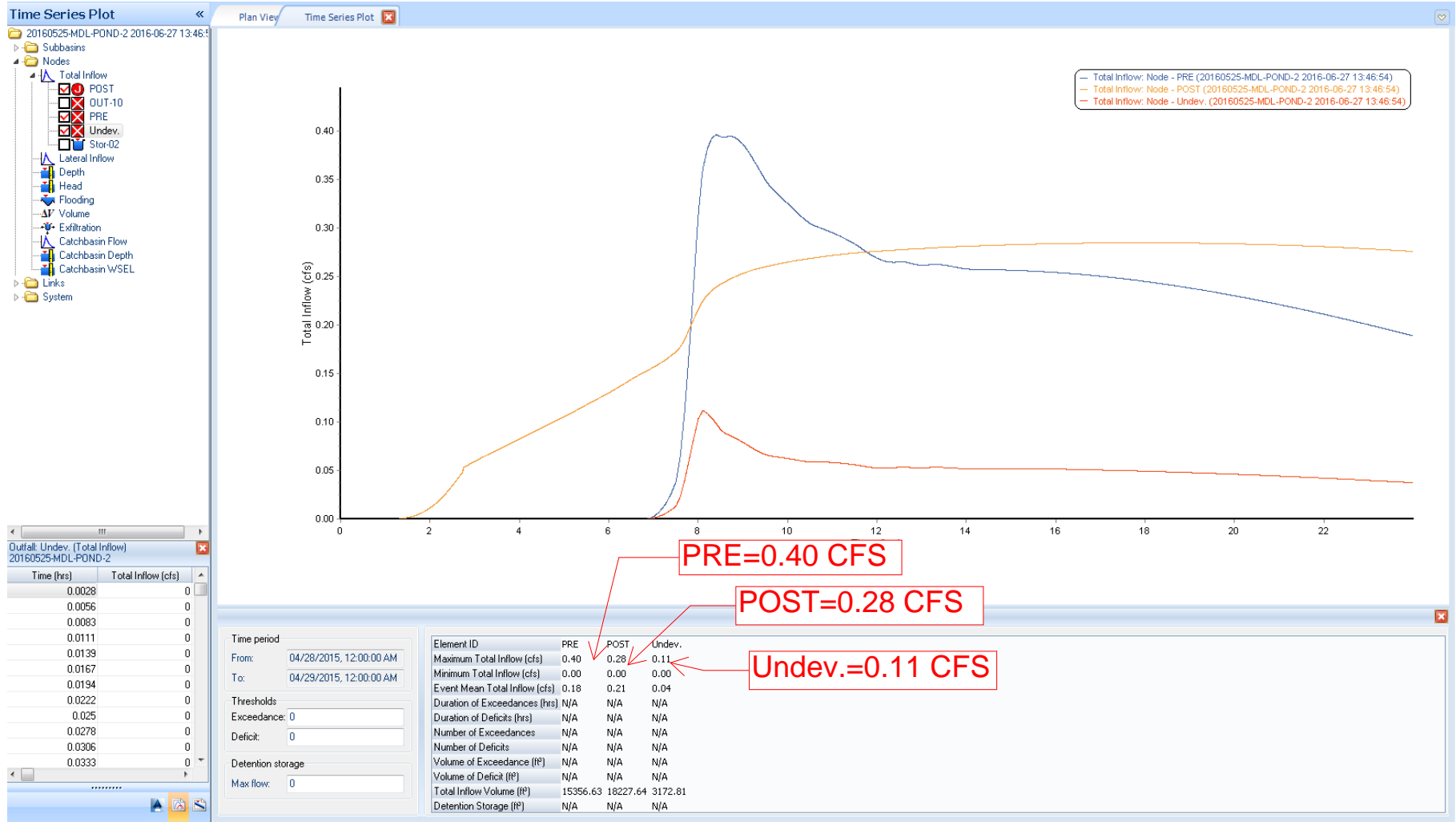


**PRE DEVELOPED TIME OF  
CONCENTRATION FLOW PATH**

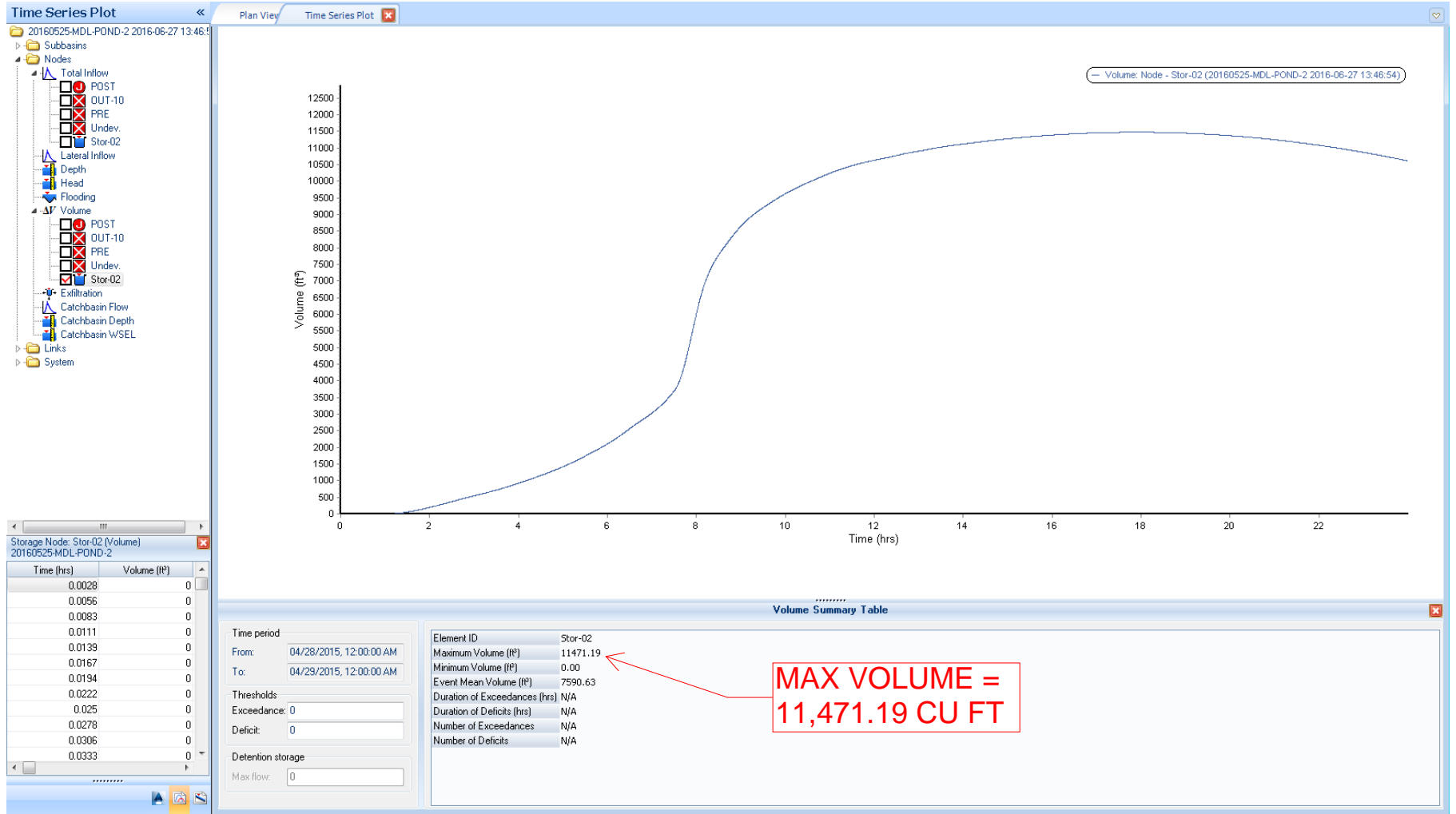
SUNSET PRIMARY SCHOOL
<b>APPENDIX B</b>

# Appendix B

## 2 YR PRE, POST, and Undeveloped DISCHARGE (CFS)



# Appendix B 2 YR POST VOLUME



# 2yr Storage Node Results

**Storage Nodes**
✕

**General**

Storage node ID:

Description:

**Physical properties**

Invert elevation:  ft

Maximum elev.:  ft

**Flow properties**

External inflows:  ...

Treatments:  ...

WSEL initial:  ft

Ponded area:  ft<sup>2</sup>

Evaporation loss:

**Storage shape**

Type:

Constant area:  ft<sup>2</sup>

Coefficient:

Exponent:

Storage curve:  ...

**Exfiltration**

Type

No exfiltration

At all elevations

Above elev.:  ft

Exfiltration rate:  ... in/hr

**Analysis summary**

Max water depth:  ft    Peak inflow:  cfs

Max water elevation:  ft    Max flooded overflow:  cfs

Total flooded vol.:  ac-in    Total time flooded:  min

ID	Invert Elev.	Max. Elev.	WSEL Initial	Ponded Area	Storage Type	Exfiltration	
1	Stor-02	0	5	0	0	Storage Curve	No exfiltration

**Orifices**

General  
Orifice ID: 002-YR  
Description:

Properties  
Type: Bottom  
Shape: Circular  
Diameter: 2.63 in  
Width: 0.00 in  
Open/close time: 0 hrs  
Crest Elev.: -4 ft  
 Flap gate  
Orifice coeff.: 0.614

Analysis summary  
Peak flow: 0.28 cfs  
Time of max occurrence: 0 17:54 days hh:mm

2yr  
0.28 cfs

**Orifices**

General  
Orifice ID: 5-25-YR  
Description:

Properties  
Type: Side  
Shape: Circular  
Diameter: 6.25 in  
Width: 0.00 in  
Open/close time: 0 hrs  
Crest Elev.: 2.5 ft  
 Flap gate  
Orifice coeff.: 0.614

Analysis summary  
Peak flow: 0.00 cfs  
Time of max occurrence: 0 00:00 days hh:mm

5-25yr  
0.00 cfs

**Orifices**

General  
Orifice ID: 100-YR  
Description:

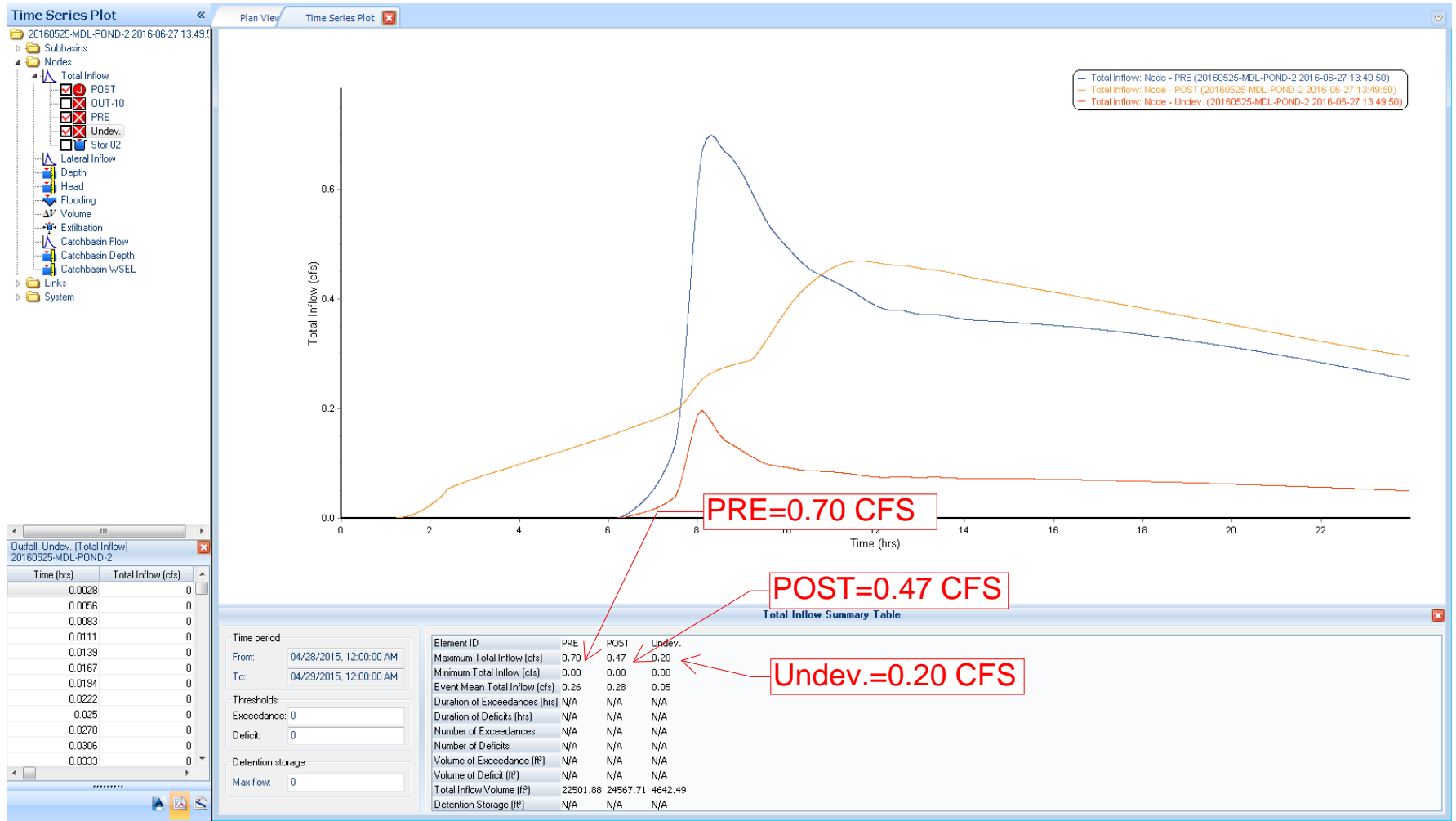
Properties  
Type: Bottom  
Shape: Circular  
Diameter: 12.00 in  
Width: 0.00 in  
Open/close time: 0 hrs  
Crest Elev.: 3.15 ft  
 Flap gate  
Orifice coeff.: 0.614

Analysis summary  
Peak flow: 0.00 cfs  
Time of max occurrence: 0 00:00 days hh:mm

100yr  
0.00 cfs

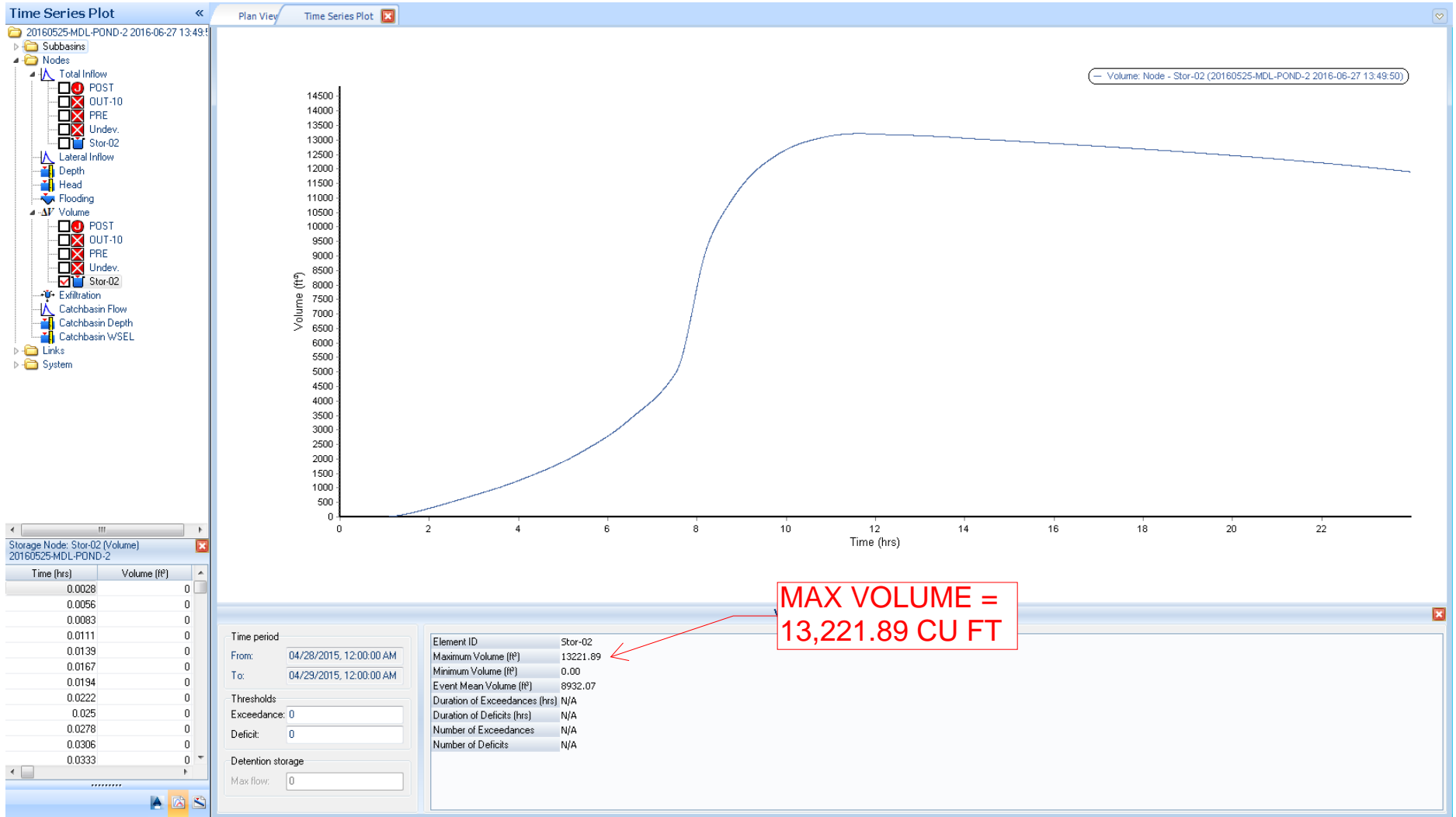
# Appendix B

## 5 YR PRE, POST, and Undeveloped DISCHARGE (CFS)





# Appendix B 5 YR POST VOLUME



# 5yr Storage Node Results

Storage Nodes
X

**General**

Storage node ID:

**Physical properties**

Invert elevation:  ft

Maximum elev.:  ft

Delete

Show

Report

Description:

**Flow properties**

External inflows:  ...

Treatments:  ...

WSEL initial:  ft

Ponded area:  ft<sup>2</sup>

Evaporation loss:

**Storage shape**

Type:  ▼

Constant area:  ft<sup>2</sup>

Coefficient:

Exponent:

Storage curve:  ▼ ...

**Exfiltration**

Type

No exfiltration

At all elevations

Above elev.:  ft

Exfiltration rate:  ... in/hr

**Analysis summary**

Max water depth:	<input type="text" value="2.74"/>	ft	Peak inflow:	<input type="text" value="2.37"/>	cfs
Max water elevation:	<input type="text" value="2.74"/>	ft	Max flooded overflow:	<input type="text" value="0.00"/>	cfs
Total flooded vol.:	<input type="text" value="0"/>	ac-in	Total time flooded:	<input type="text" value="0"/>	min

	ID /	Invert Elev.	Max. Elev.	WSEL Initial	Ponded Area	Storage Type	Exfiltration
1	Stor-02	0	5	0	0	Storage Curve	No exfiltration

Close

Help

**Orifices**

General  
Orifice ID: 002-YR  
Description:

Properties  
Type: Bottom Diameter: 2.63 in  
Shape: Circular Width: 0.00 in  
Open/close time: 0 hrs Crest Elev.: -4 ft  
 Flap gate Orifice coeff.: 0.614

Analysis summary  
Peak flow: 0.30 cfs  
Time of max occurrence: 0 11:37 days hh:mm

2yr  
0.30 cfs

**Orifices**

General  
Orifice ID: 5-25-YR  
Description:

Properties  
Type: Side Diameter: 6.25 in  
Shape: Circular Width: 0.00 in  
Open/close time: 0 hrs Crest Elev.: 2.5 ft  
 Flap gate Orifice coeff.: 0.614

Analysis summary  
Peak flow: 0.17 cfs  
Time of max occurrence: 0 11:37 days hh:mm

5-25yr  
0.17 cfs

**Orifices**

General  
Orifice ID: 100-YR  
Description:

Properties  
Type: Bottom Diameter: 12.00 in  
Shape: Circular Width: 0.00 in  
Open/close time: 0 hrs Crest Elev.: 3.15 ft  
 Flap gate Orifice coeff.: 0.614

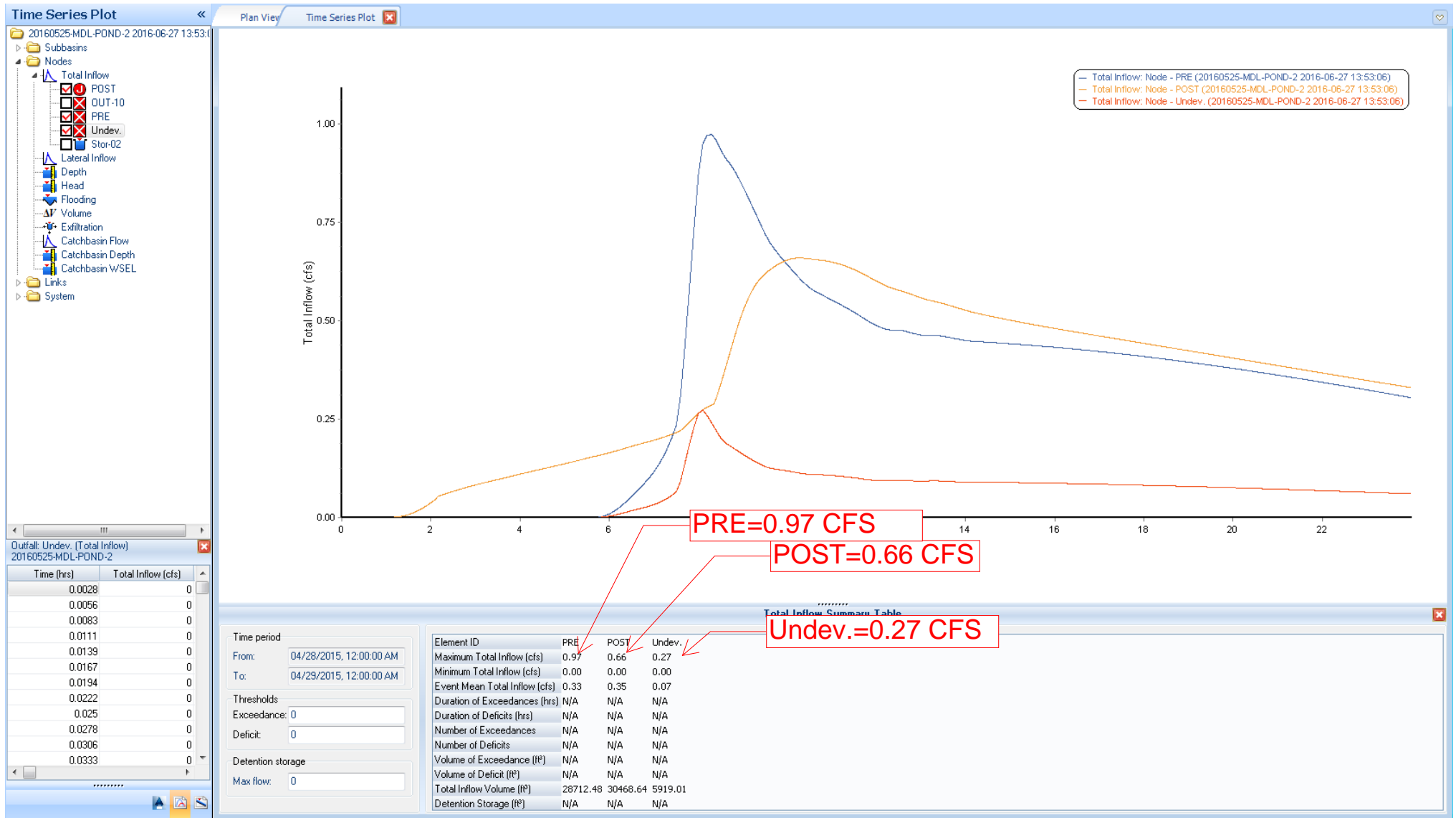
Analysis summary  
Peak flow: 0.00 cfs  
Time of max occurrence: 0 00:00 days hh:mm

Connectivity  
From (inlet): Stor-02 Swap Invert elev.: 0 ft  
To (outlet): POST Invert elev.: 0 ft

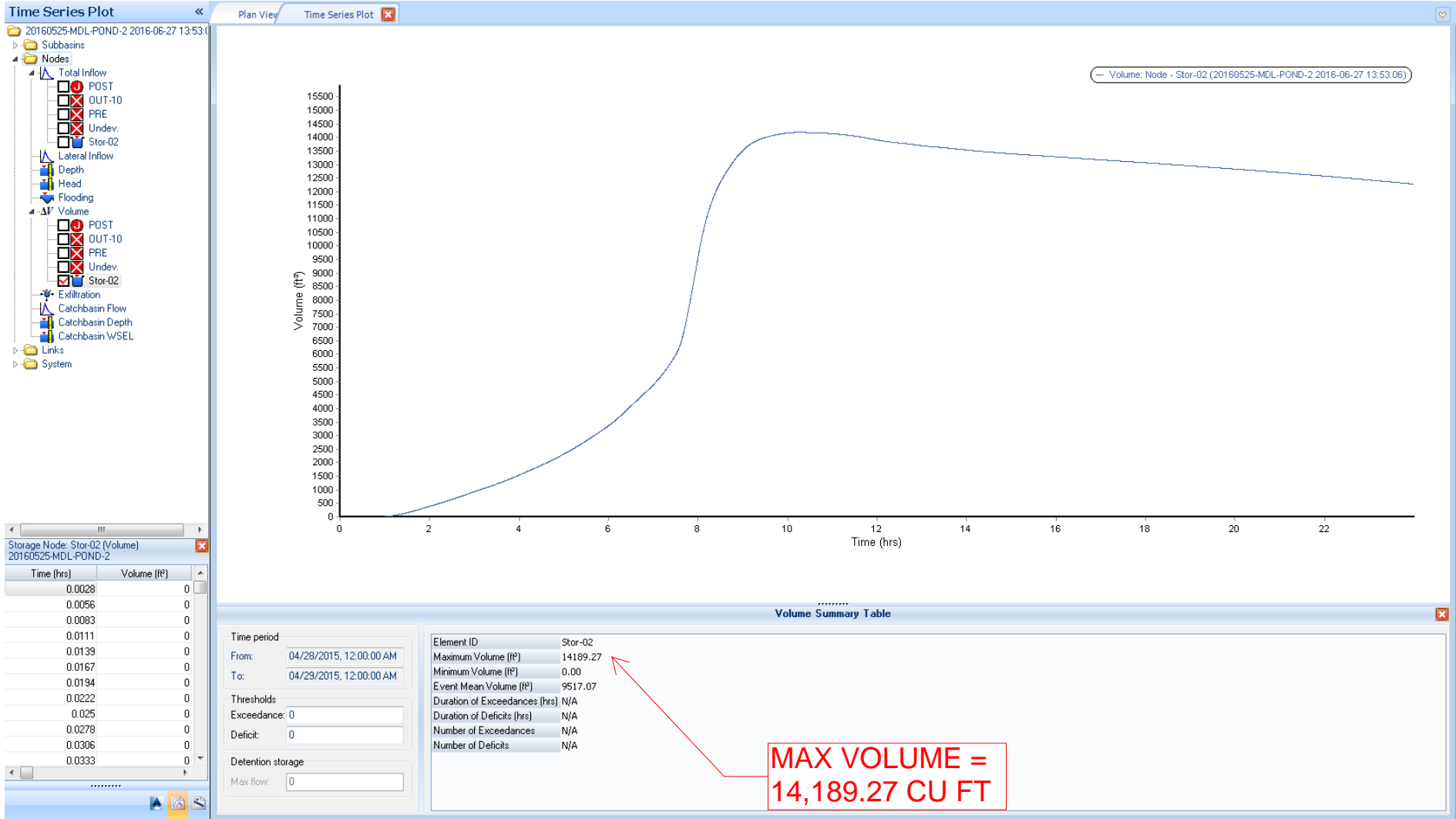
100yr  
0.00 cfs



# Appendix B 10 YR PRE, POST, and Undeveloped DISCHARGE (CFS)



# Appendix B 10 YR POST VOLUME



# 10yr Storage Node Results

X
Storage Nodes

**General**

Storage node ID:

Description:

**Flow properties**

External inflows:  ...

Treatments:  ...

WSEL initial:  ft

Ponded area:  ft<sup>2</sup>

Evaporation loss:

**Exfiltration**

Type

No exfiltration

At all elevations

Above elev.:  ft

**Analysis summary**

Max water depth:  ft    Peak inflow:  cfs

Max water elevation:  ft    Max flooded overflow:  cfs

Total flooded vol.:  ac-in    Total time flooded:  min

**Physical properties**

Invert elevation:  ft

Maximum elev.:  ft

**Storage shape**

Type:  ▼

Constant area:  ft<sup>2</sup>

Coefficient:

Exponent:

Storage curve:  ▼ ...

Exfiltration rate:  ... in/hr

Delete

Show

Report

	ID /	Invert Elev.	Max. Elev.	WSEL Initial	Ponded Area	Storage Type	Exfiltration
1	Stor-02	0	5	0	0	Storage Curve	No exfiltration

Close

Help

**Orifices**

General  
Orifice ID: 002-YR  
Description:

Properties  
Type: Bottom Diameter: 2.63 in  
Shape: Circular Width: 0.00 in  
Open/close time: 0 hrs Crest Elev.: -4 ft  
 Flap gate Orifice coeff.: 0.614

Analysis summary  
Peak flow: 0.31 cfs  
Time of max occurrence: 0 10:16 days hh:mm

2yr  
0.31 cfs

**Orifices**

General  
Orifice ID: 5-25-YR  
Description:

Properties  
Type: Side Diameter: 6.25 in  
Shape: Circular Width: 0.00 in  
Open/close time: 0 hrs Crest Elev.: 2.5 ft  
 Flap gate Orifice coeff.: 0.614

Analysis summary  
Peak flow: 0.35 cfs  
Time of max occurrence: 0 10:16 days hh:mm

5-25yr  
0.35 cfs

**Orifices**

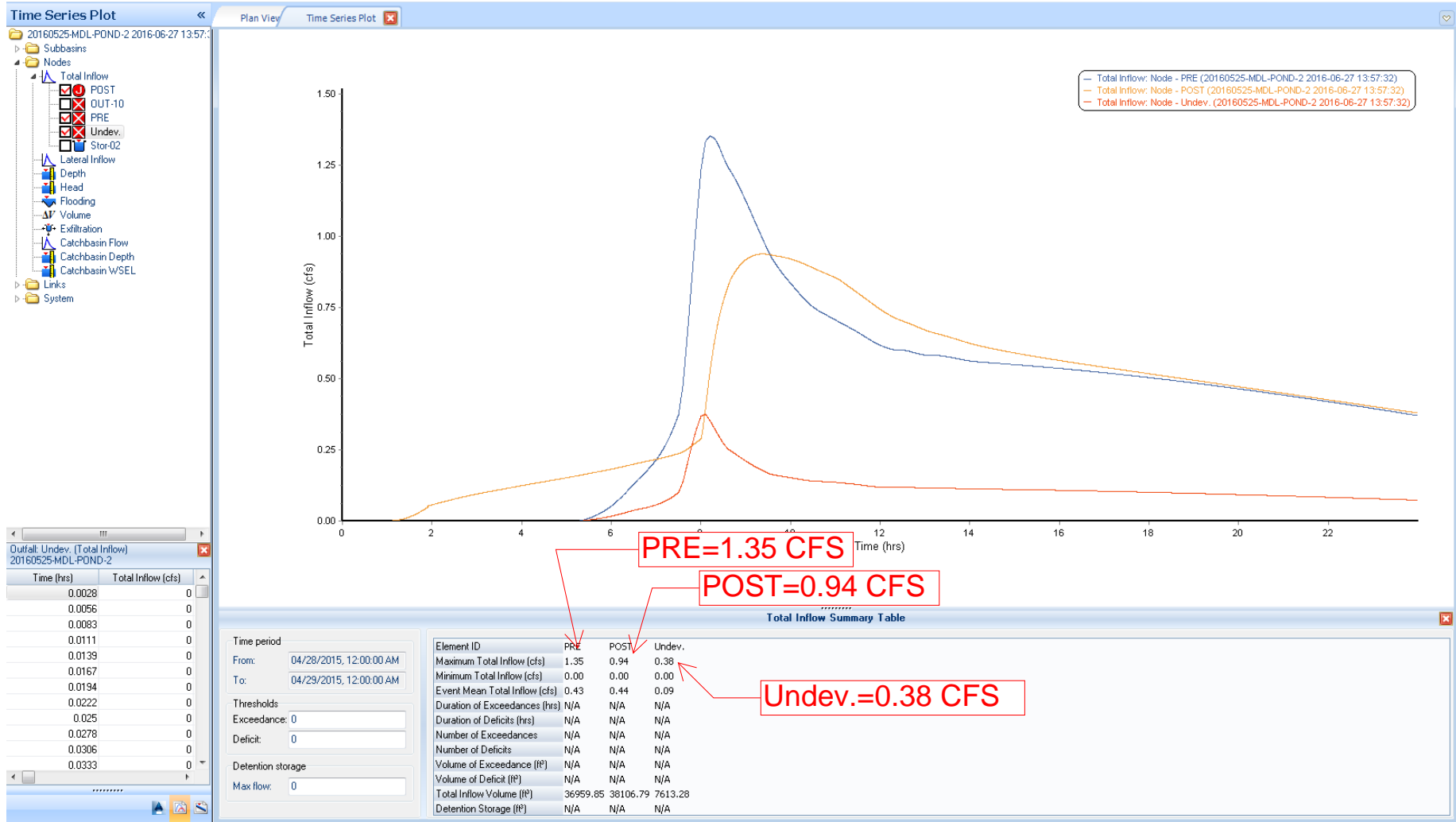
General  
Orifice ID: 100-YR  
Description:

Properties  
Type: Bottom Diameter: 12.00 in  
Shape: Circular Width: 0.00 in  
Open/close time: 0 hrs Crest Elev.: 3.15 ft  
 Flap gate Orifice coeff.: 0.614

Analysis summary  
Peak flow: 0.00 cfs  
Time of max occurrence: 0 00:00 days hh:mm

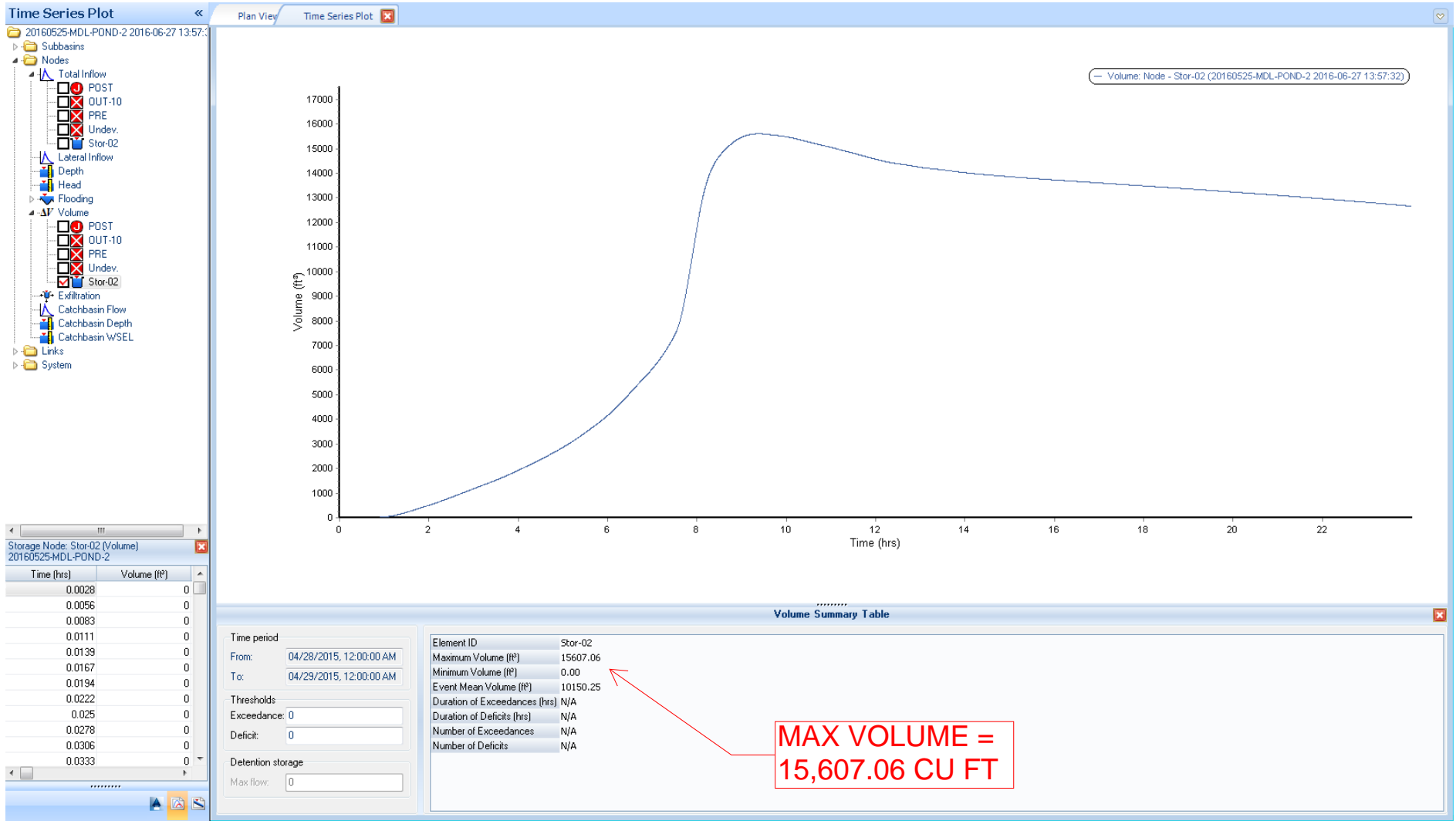
100yr  
0.00 cfs

# Appendix B 25 YR PRE, POST, and Undeveloped DISCHARGE (CFS)





# Appendix B 25 YR POST VOLUME



# 25yr Storage Node Results

X
Storage Nodes

**General**

Storage node ID:

**Physical properties**

Invert elevation:  ft

Maximum elev.:  ft

Delete

Show

Report

Description:

**Flow properties**

External inflows:  ...

Treatments:  ...

WSEL initial:  ft

Ponded area:  ft<sup>2</sup>

Evaporation loss:

**Storage shape**

Type:  ▼

Constant area:  ft<sup>2</sup>

Coefficient:

Exponent:

Storage curve:  ▼ ...

**Exfiltration**

Type

No exfiltration

At all elevations

Above elev.:  ft

Exfiltration rate:  ... in/hr

**Analysis summary**

Max water depth: <input type="text" value="3.11"/> ft	Peak inflow: <input type="text" value="3.35"/> cfs
Max water elevation: <input type="text" value="3.11"/> ft	Max flooded overflow: <input type="text" value="0.00"/> cfs
Total flooded vol.: <input type="text" value="0"/> ac-in	Total time flooded: <input type="text" value="0"/> min

ID	Invert Elev.	Max. Elev.	WSEL Initial	Ponded Area	Storage Type	Exfiltration
1	0	5	0	0	Storage Curve	No exfiltration

Close

Help

**Orifices**

General  
Orifice ID: 002-YR  
Description:

Properties  
Type: Bottom  
Shape: Circular  
Diameter: 2.63 in  
Width: 0.00 in  
Open/close time: 0 hrs  
Crest Elev.: -4 ft  
 Flap gate  
Orifice coeff.: 0.614

Analysis summary  
Peak flow: 0.32 cfs  
Time of max occurrence: 0 09:22 days hh:mm

2yr  
0.32 cfs

**Orifices**

General  
Orifice ID: 5-25-YR  
Description:

Properties  
Type: Side  
Shape: Circular  
Diameter: 6.25 in  
Width: 0.00 in  
Open/close time: 0 hrs  
Crest Elev.: 2.5 ft  
 Flap gate  
Orifice coeff.: 0.614

Analysis summary  
Peak flow: 0.62 cfs  
Time of max occurrence: 0 09:22 days hh:mm

5-25yr  
0.62 cfs

**Orifices**

General  
Orifice ID: 100-YR  
Description:

Properties  
Type: Bottom  
Shape: Circular  
Diameter: 12.00 in  
Width: 0.00 in  
Open/close time: 0 hrs  
Crest Elev.: 3.15 ft  
 Flap gate  
Orifice coeff.: 0.614

Analysis summary  
Peak flow: 0.00 cfs  
Time of max occurrence: 0 00:00 days hh:mm

100yr  
0.00 cfs

# 100yr Storage Node Results

X
Storage Nodes

**General**

Storage node ID:

Description:

**Flow properties**

External inflows:  ...

Treatments:  ...

WSEL initial:  ft

Ponded area:  ft<sup>2</sup>

Evaporation loss:

**Exfiltration**

Type

No exfiltration

At all elevations

Above elev.:  ft

**Analysis summary**

Max water depth:  ft

Max water elevation:  ft

Total flooded vol.:  ac-in

**Physical properties**

Invert elevation:  ft

Maximum elev.:  ft

**Storage shape**

Type:  ▾

Constant area:  ft<sup>2</sup>

Coefficient:

Exponent:

Storage curve:  ▾ ...

Exfiltration rate:  ... in/hr

Peak inflow:  cfs

Max flooded overflow:  cfs

Total time flooded:  min

Delete

Show

Report

ID /	Invert Elev.	Max. Elev.	WSEL Initial	Ponded Area	Storage Type	Exfiltration	
1	Stor-02	0	5	0	0	Storage Curve	No exfiltration

Close

Help



# Presumptive Approach Calculator ver. 1.2

Catchment Data

Project Name: **Sunset Primary School**  
 Project Address: **2531 Oxford St.**  
**West Linn, OR**  
 Designer: **Andrew Chung**  
 Company: **KPFF**

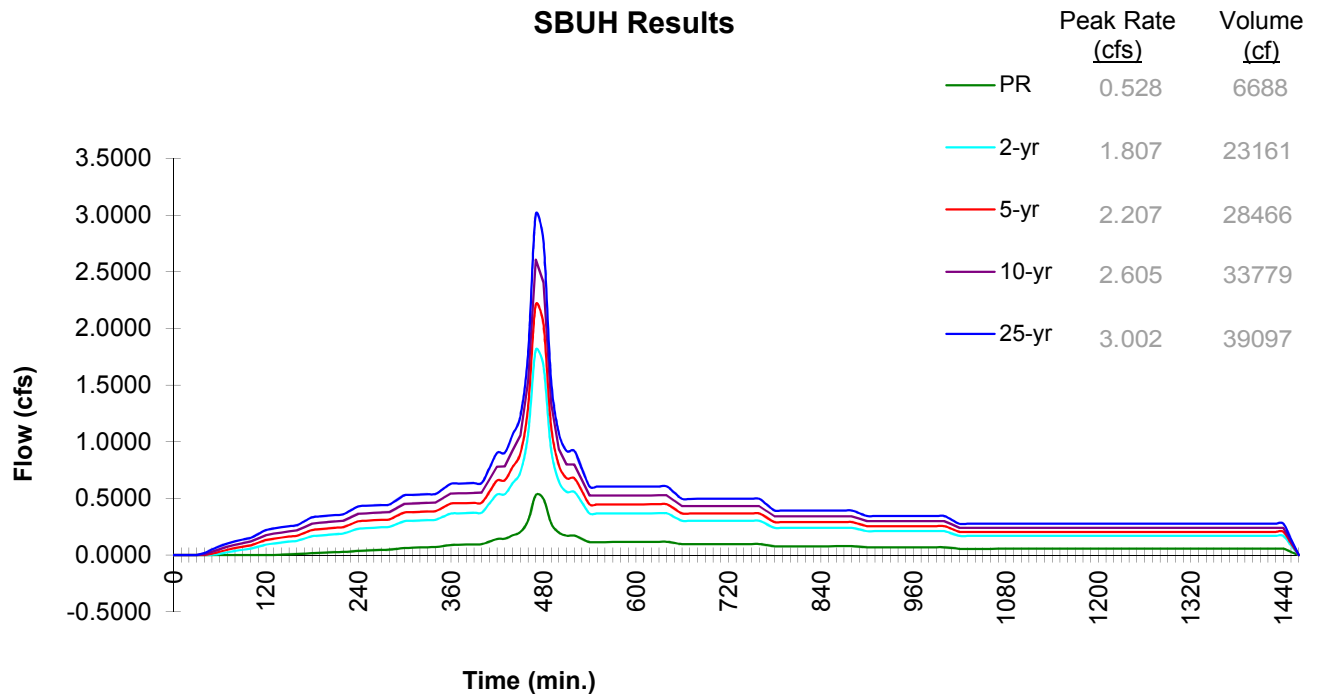
Catchment ID: **1**  
 Date: **06/08/16**  
 Permit Number:

Run Time 6/8/2016 9:14:55 AM

Drainage Catchment Information		
Catchment ID	1	
	<b>Catchment Area</b>	
Impervious Area	128,000 SF	<b>Catchment Area Exceeds 1 Acre</b>
Impervious Area	2.94 ac	
Impervious Area Curve Number, $CN_{imp}$	98	
Time of Concentration, $T_c$ , minutes	5 min.	
Site Soils & Infiltration Testing Data		
Infiltration Testing Procedure:	Open Pit Falling Head	
Native Soil Field Tested Infiltration Rate ( $I_{test}$ ):	3 in/hr	
Bottom of Facility Meets Required Separation From High Groundwater Per BES SWMM Section 1.4:	Yes	
Correction Factor Component		
$CF_{test}$ (ranges from 1 to 3)	2	
Design Infiltration Rates		
$I_{dsgn}$ for Native ( $I_{test} / CF_{test}$ ):	1.50 in/hr	
$I_{dsgn}$ for Imported Growing Medium:	2.00 in/hr	

**Execute SBUH**

## SBUH Results





**Presumptive Approach Calculator ver. 1.2**

Catchment ID: **1**

Run Time 6/8/2016 9:17:53 AM

Project Name: **Sunset Primary School**

Catchment ID: **1**

Date: **6/8/2016**

**Instructions:**

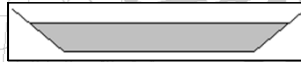
1. Identify which Stormwater Hierarchy Category the facility.
2. Select Facility Type.
3. Identify facility shape of surface facility to more accurately estimate surface volume, except for Swales and sloped planters that use the PAC Sloped Facility Worksheet to enter data.
4. Select type of facility configuration.
5. Complete data entry for all highlighted cells.

Catchment facility will meet Hierarchy Category: **3**

Goal Summary:

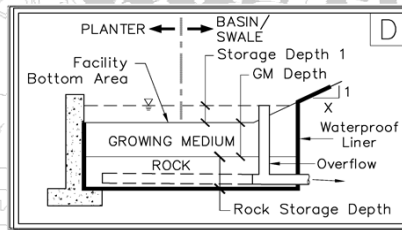
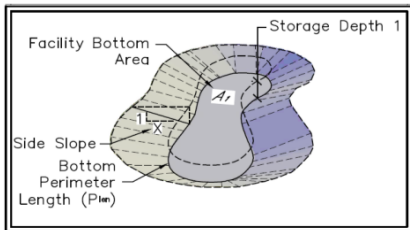
Hierarchy Category	SWMM Requirement	RESULTS box below needs to display...	
		Pollution Reduction as a	10-yr (aka disposal) as a
3	Off-site flow to drainageway, river, or storm-only pipe system.	PASS	N/A

Facility Type = **Basin**



Facility Shape: **Amoeba**

Facility Configuration: **D**



**DATA FOR ABOVE GRADE STORAGE COMPONENT**

**BELOW GRADE STORAGE**

Calculation Guide  
Max. Rock Stor.  
Bottom Area  
**4,393 SF**

Facility Bottom Area = **3,445 sf**  
 Bottom Perimeter Length = **316.0 ft**  
 Facility Side Slope = **3** to **1**  
 Storage Depth 1 = **6 in**  
 Growing Medium Depth = **18 in**  
 Freeboard Depth = **12 in**

Surface Capacity at Depth 1 = **1,960 cf**  
 Infiltration Area at 75% Depth1 = **4,156 SF**  
 GM Design Infiltration Rate = **2.00 in/hr**  
 Infiltration Capacity = **0.192 cfs**

Rock Storage Capacity = \_\_\_\_\_ cf

Native Design Infiltration Rate = \_\_\_\_\_ in/hr  
 Infiltration Capacity = \_\_\_\_\_ cfs

<b>RESULTS</b>	Overflow Volume			
Pollution Reduction	<b>PASS</b>	0 CF	<b>26%</b> Surf. Cap. Used	<a href="#">Run PAC</a>
Output File				
Peak cfs	<b>2-yr</b>	<b>5-yr</b>	<b>10-yr</b>	<b>25-yr</b>
	1.807	2.207	2.605	3.002

<b>FACILITY FACTS</b>	Total Facility Area Including Freeboard = <b>4,867 SF</b>
	Sizing Ratio (Total Facility Area / Catchment Area) = <b>0.038</b>

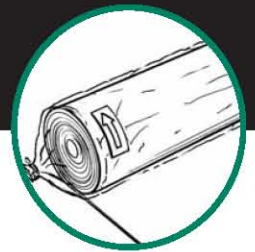
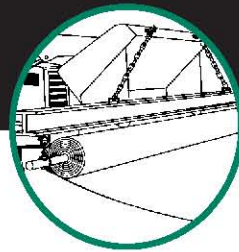
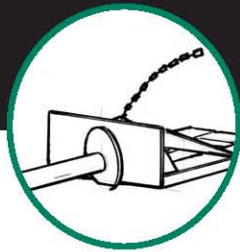


Basin Calcs															
Basin	Total Area (sf)	Total Area (ac)	Proposed Pervious (sf)	Proposed Impervious (sf)	Impervious C	Pervious C	Adjusted C	Storm Interval (yr)	Time of Conc. (min)	Intensity (in/hr)	Q (cfs)	Pipe Size Calc (in)	Pipe Size Design (in)	Pipe Q Design (cfs)	Pipe Cap. Used (%)
1	20068	0.46	7023.8	13044.2	0.9	0.25	0.67	100	5.00	3.45	1.069	8	8	1.7088	63%
2	9435	0.22	1415.25	8019.75	0.9	0.25	0.80	100	5.00	3.45	0.600	6	8	1.7088	35%
3	29456	0.68	23564.8	5891.2	0.9	0.25	0.38	100	5.00	3.45	0.887	8	8	1.7088	52%
4	14157	0.33	11325.6	2831.4	0.9	0.25	0.38	100	5.00	3.45	0.426	6	8	1.4799	29%
5	2787	0.06	1672.2	1114.8	0.9	0.25	0.51	100	5.00	3.45	0.113	6	8	1.4799	8%
6	9261	0.21	2284.5	6976.5	0.9	0.25	0.74	100	5.00	3.45	0.543	8	8	1.7088	32%
7	11338	0.26	7936.6	3401.4	0.9	0.25	0.45	100	5.00	3.45	0.400	6	8	1.2083	33%
8	9790	0.22	3661.46	6128.54	0.9	0.25	0.66	100	5.00	3.45	0.509	6	8	1.2083	42%
9	7996	0.18	2109	5887	0.9	0.25	0.73	100	5.00	3.45	0.461	8	8	1.7088	27%
10	7513	0.17	1564	5949	0.9	0.25	0.76	100	5.00	3.45	0.455	8	8	1.7088	27%
11	7995	0.18	1943	6052	0.9	0.25	0.74	100	5.00	3.45	0.470	8	8	1.7088	27%
12	15405	0.35	4621.5	10783.5	0.9	0.25	0.71	100	5.00	3.45	0.860	8	8	1.7088	50%
13	9003	0.21	2700.9	6302.1	0.9	0.25	0.71	100	5.00	3.45	0.503	6	8	1.2083	42%
14	5504	0.13	1100.8	4403.2	0.9	0.25	0.77	100	5.00	3.45	0.336	6	8	1.2083	28%
15	11057	0.25	11057	0	0.9	0.25	0.25	100	5.00	3.45	0.219	6	8	1.2083	18%
R1	9781	0.22	0	9781	0.9	0.25	0.90	100	5.00	3.45	0.697	8	8	1.2083	58%
R2	8705	0.20	0	8705	0.9	0.25	0.90	100	5.00	3.45	0.621	8	8	1.2083	51%
R3	4606	0.11	0	4606	0.9	0.25	0.90	100	5.00	3.45	0.328	6	8	1.2083	27%
R4	5657	0.13	0	5657	0.9	0.25	0.90	100	5.00	3.45	0.403	6	8	1.2083	33%
R5	4922	0.11	0	4922	0.9	0.25	0.90	100	5.00	3.45	0.351	6	8	1.2083	29%
R6	6950	0.16	0	6950	0.9	0.25	0.90	100	5.00	3.45	0.495	6	8	1.2083	41%
R7	4982	0.11	0	4982	0.9	0.25	0.90	100	5.00	3.45	0.355	6	8	1.2083	29%
<b>Total</b>	<b>216368</b>	<b>3.92</b>	<b>83980.41</b>	<b>86784.59</b>											

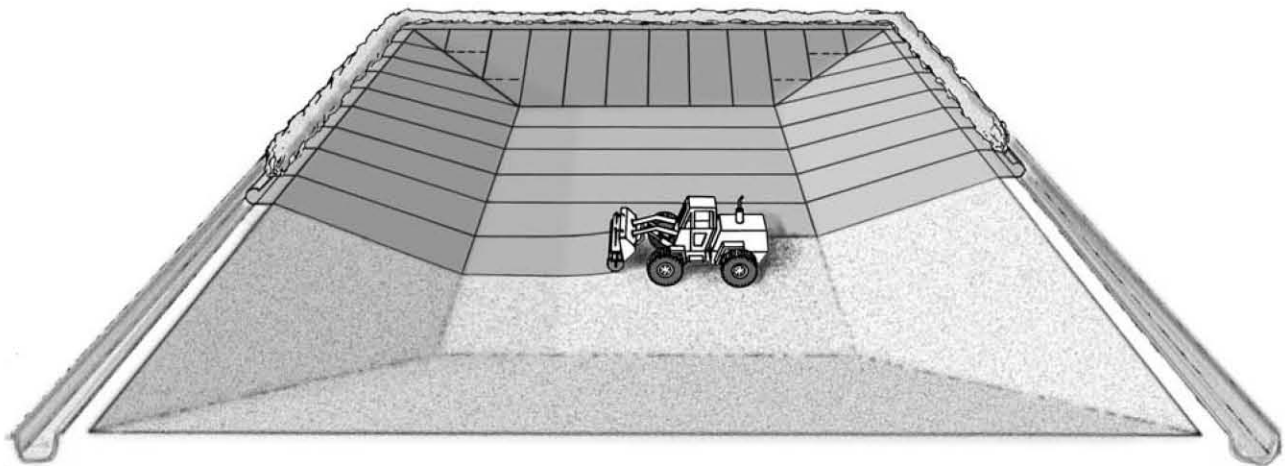
Pipe Conveyance Calcs																
Basins	Total Area (sf)	Total Area (ac)	Proposed Pervious (sf)	Proposed Impervious (sf)	Impervious C	Pervious C	Adjusted C	Storm Interval (yr)	Time of Conc. (min)	Intensity (in/hr)	Q (cfs)	Pipe Size (in)	Pipe Size Design (in)	Pipe Number	Pipe Q Design (cfs)	Pipe Cap. Used (%)
1	20068	0.46	7023.8	13044.2	0.9	0.250	0.67	100.00	5.00	3.45	1.069	8	8		1.4799	72%
1+2	29503	0.68	8439.05	21063.95	0.9	0.250	0.71	100.00	5.00	3.45	1.669	10	10		2.6832	62%
1-3	58959	1.35	32003.85	26955.15	0.9	0.250	0.55	100.00	5.00	3.45	2.555	10	10		2.6832	95%
1-4	73116	1.68	43329.45	29786.55	0.9	0.250	0.51	100.00	5.00	3.45	2.981	12	12		4.3631	68%
1-5	75903	1.74	45001.65	30901.35	0.9	0.250	0.51	100.00	5.00	3.45	3.094	12	12		4.3631	71%
1-6	85164	1.96	47286.15	37877.85	0.9	0.250	0.54	100.00	5.00	3.45	3.636	12	12		4.3631	83%
1-8	106292	2.44	58884.21	47407.79	0.9	0.250	0.54	100.00	5.00	3.45	4.545	12	12		5.0381	90%
8+7+R1	30909	0.71	11598.06	19310.94	0.9	0.250	0.66	100.00	5.00	3.45	1.606	8	8		1.7088	94%
8+7+6+R1	40170	0.92	13882.56	26287.44	0.9	0.250	0.68	100.00	5.00	3.45	2.149	10	10		3.0982	69%
1-8 + R1	116073	2.66	58884.21	57188.79	0.9	0.250	0.57	100.00	5.00	3.45	5.242	15	15		9.1346	57%
1-8 + 12 + R1 + R3	136084	3.12	63505.71	72578.29	0.9	0.250	0.60	100.00	5.00	3.45	6.431	15	15		9.1346	70%
9+R2+R4	22358	0.51	2109	20249	0.9	0.250	0.84	100.00	5.00	3.45	1.485	10	8		1.4799	100%
9-10+R2+R4	29871	0.69	3673	26198	0.9	0.250	0.82	100.00	5.00	3.45	1.940	10	10		3.0982	63%
9-11+R2+R4+R5	42788	0.98	5616	37172	0.9	0.250	0.81	100.00	5.00	3.45	2.761	12	10		2.6832	103%
9-11+14+R2+R4+R5+R7	53274	1.22	6716.8	46557.2	0.9	0.250	0.82	100.00	5.00	3.45	3.452	12	12		4.3631	79%
1-14+Rs	205311	4.71	72923.41	132387.59	0.9	0.250	0.67	100.00	5.00	3.45	10.881	18	18		12.8639	85%

Pipe Size	Pipe Mat.	Slope (%)	Allowable Q (cfs)	Slope (%)	Allowable Q (cfs)	Slope (%)	Allowable Q (cfs)	Slope (%)	Allowable Q (cfs)	Slope (%)	Allowable Q (cfs)
4	PVC	0.55	0.1411	1	0.1903	1.5	0.2331	2	0.2691	2.5	0.3009
6	PVC	0.55	0.4161	1	0.5611	1.5	0.6871	2	0.7934	2.5	0.8871
8	PVC	0.55	0.8961	1	1.2083	1.5	1.4799	2	1.7088	2.5	1.9105
10	PVC	0.55	1.6247	1	2.1908	1.5	2.6832	2	3.0982	2.5	3.4639
12	PVC	0.55	2.642	1	3.5625	1.5	4.3631	2	5.0381	2.5	5.6327
15	PVC	0.55	4.7902	1	6.4592	1.5	7.9108	2	9.1346	2.5	10.2128
18	PVC	0.55	7.7895	1	10.5033	1.5	12.8639	2	14.8539	2.5	16.6072
21	PVC	0.55	11.7499	1	15.8435	1.5	19.4043	2	22.4061	2.5	25.0508
24	PVC	0.55	16.7756	1	22.6202	1.5	27.704	2	31.9898	2.5	35.7657
30	PVC	0.55	30.4162	1	41.0132	1.5	50.2307	2	58.0014	2.5	64.8475

West Linn Design Standards:  
 minimum Manning's n = 0.013  
 minimum slope = 0.0055  
 tc = 5min  
 minimum design storm = 100 yr



## Installation Guidelines



# BENTOMAT<sup>®</sup> CLAYMAX<sup>®</sup>

Geosynthetic Clay Liners

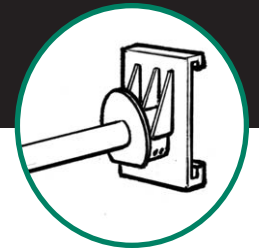
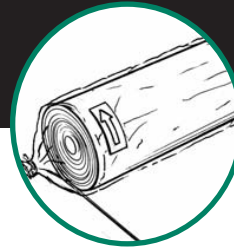


**NOTICE:** This document is intended for use as a GENERAL GUIDELINE for the installation of CETCO's GCLs. The information and data contained herein are believed to be accurate and reliable. CETCO makes no warranty of any kind and accepts no responsibility for the results obtained through application of this information. Installation guidelines are subject to periodic changes. Please consult our CETCO Engineering Website @ [www.cetco.com/LTE](http://www.cetco.com/LTE) for the most recent version.





# TABLE OF CONTENTS



1. Introduction . . . . .	3
2. Equipment Requirements . . . . .	3
3. Shipping, Unloading, and Storage . . . . .	5
4. Subgrade Preparation . . . . .	6
5. Installation . . . . .	7
6. Anchorage . . . . .	9
7. Seaming . . . . .	10
8. Sealing Around Penetrations and Structures . . . . .	11
9. Damage Repair . . . . .	14
10. Cover Placement . . . . .	14
11. Hydration . . . . .	15



- 1.1** This document provides procedures for the installation of CETCO's GCLs in a manner that maximizes safety, efficiency, and the physical integrity of the GCL.
- 1.2** These guidelines are based upon many years of experience at a variety of sites and should be generally applicable to any type of lining project using CETCO's GCLs. Variance from these guidelines is at the engineer's discretion.
- 1.3** The performance of the GCL is wholly dependent on the quality of its installation. It is the installer's responsibility to adhere to these guidelines, and to the project specifications and drawings, as closely as possible. It is the engineer's and owner's responsibility to provide construction quality assurance (CQA) for the installation, to ensure that the installation has been executed properly. This document covers only installation procedures.
- 1.4** For additional guidance, refer to ASTM D5888 (Standard Guide For Storage and Handling of Geosynthetic Clay Liners) and ASTM D 6102 (Standard Guide For Installation of Geosynthetic Clay Liners).

## EQUIPMENT REQUIREMENTS

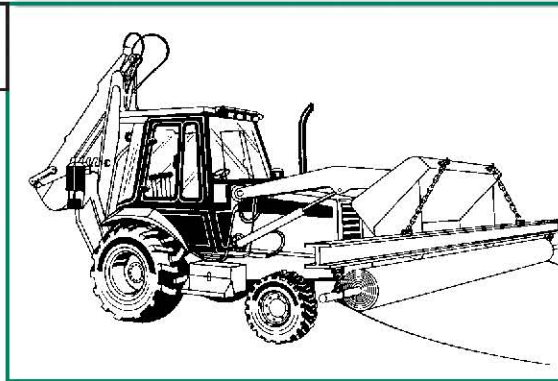
- 2.1** CETCO GCLs are delivered in rolls typically 2,600-2,950 lbs (1180-1340 kg). Roll dimensions and weights will vary with the dimensions of the product ordered. It is necessary to support this weight using an appropriate core pipe as indicated in Table 1. For any installation, the core pipe must not deflect more than 3 inches (75 mm) as measured from end to midpoint when a full GCL roll is lifted.

**TABLE 1 CORE REQUIREMENTS**

Product(s)	Nominal GCL Roll Size W x Dia. Ft. (m) x in. (mm)	Typical GCL Roll Wt., lbs. (kg)	Interior Core Size, in. (mm)	Core Pipe Length x Diameter, ft. x in. (m x mm)	Minimum Core Pipe Strength
Bentomat DN, SDN	16' x 24" (4.9 x 610)	2,650 (1200)	3 3/4 (100)	20 x 2.88"O.D.(6.1 m x 73 mm)	XXH
Bentomat ST	16' x 24" (4.9 x 610)	2,600 (1180)	3 3/4 (100)	20 x 2.88"O.D.(6.1 m x 73 mm)	XXH
Bentomat CLT	16' x 26" (4.9 x 660)	2,950 (1340)	3 3/4 (100)	20 x 2.88"O.D.(6.1 m x 73 mm)	XXH
Claymax 200R	16' x 20" (4.9 x 510)	2,750 (1250)	3 3/4 (100)	20 x 2.88"O.D.(6.1 m x 73 mm)	XXH
Bentomat CL	16' x 25" (4.9 x 635)	2,675 (1213)	3 3/4 (100)	20 x 2.88"O.D.(6.1 m x 73 mm)	XXH

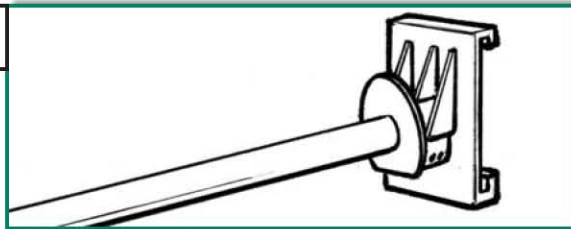
- 2.2 Lifting chains or straps appropriately rated should be used in combination with a spreader bar made from an I-beam as shown in Figure 1.

**FIGURE 1** **SPREADER BAR LIFTING ASSEMBLY**

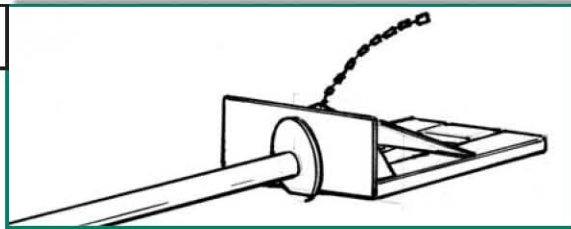


- 2.3 The spreader bar ensures that lifting chains or straps do not chafe against the ends of the GCL roll, allowing it to rotate freely during installation. Spreader bar and core pipe kits are available through CETCO.
- 2.4 A front end loader, backhoe, dozer, or other equipment can be utilized with the spreader bar and core pipe or slings. Alternatively, a forklift with a “stinger” attachment may be used for on-site handling. A forklift without a stinger attachment should not be used to lift or handle the GCL rolls. Stinger attachments (Figure 2-4) are specially fabricated to fit various forklift makes and models.

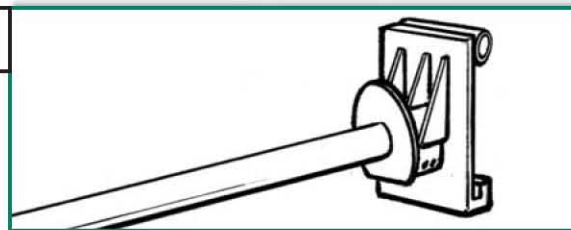
**FIGURE 2** **HOOK MOUNT**


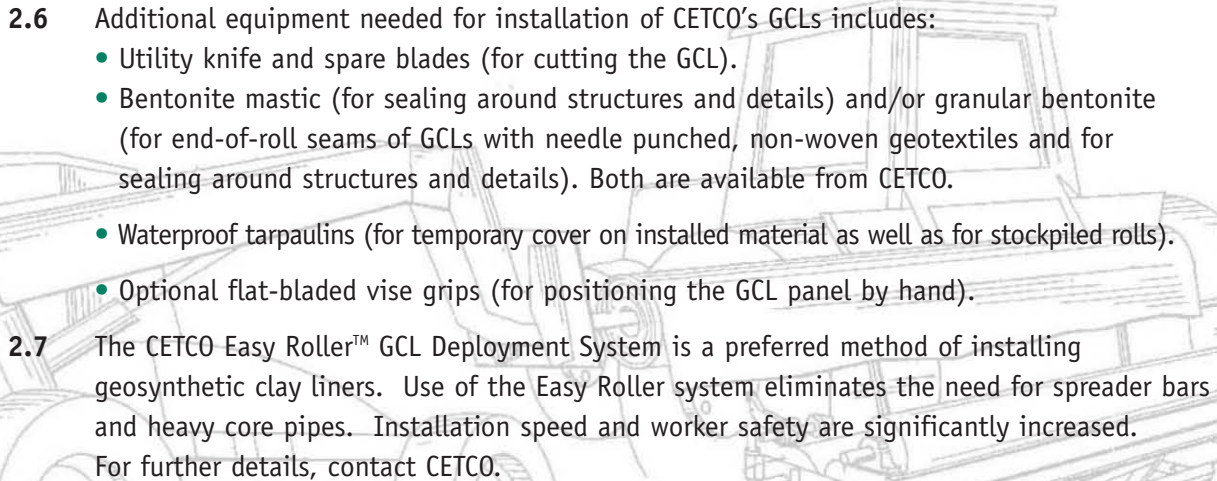


**FIGURE 3** **FORK MOUNT**  
(with fork pockets)

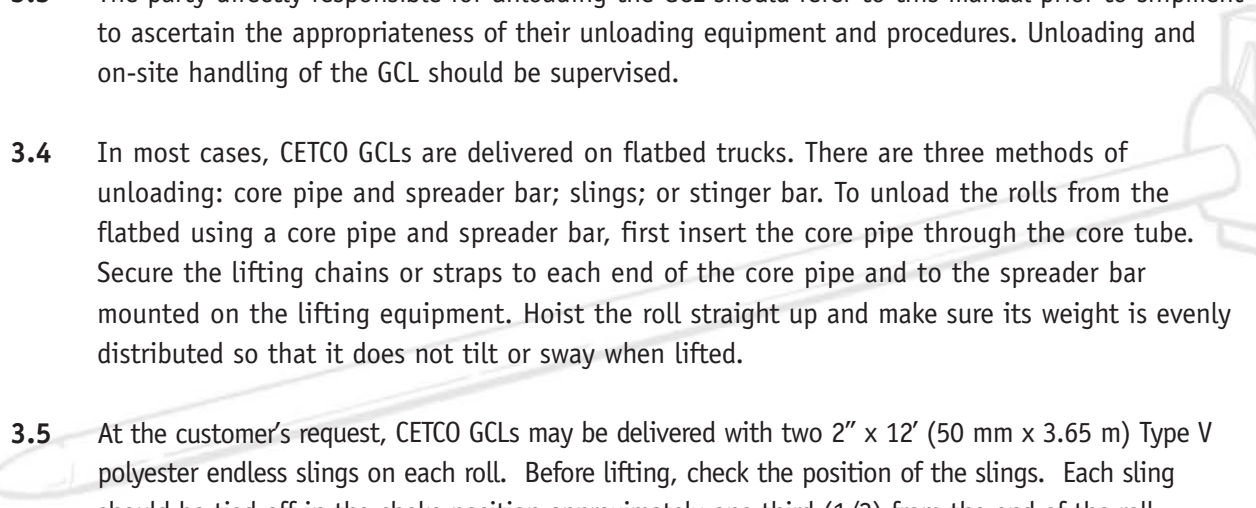


**FIGURE 4** **PIN MOUNT**



- 
- 
- 2.5** When installing over certain geosynthetic materials, a 4-wheel, all-terrain vehicle (ATV) can be used to deploy the GCL. An ATV can be driven directly on the GCL provided that no sudden stops, starts, or turns are made.
- 2.6** Additional equipment needed for installation of CETCO's GCLs includes:
- Utility knife and spare blades (for cutting the GCL).
  - Bentonite mastic (for sealing around structures and details) and/or granular bentonite (for end-of-roll seams of GCLs with needle punched, non-woven geotextiles and for sealing around structures and details). Both are available from CETCO.
  - Waterproof tarpaulins (for temporary cover on installed material as well as for stockpiled rolls).
  - Optional flat-bladed vise grips (for positioning the GCL panel by hand).
- 2.7** The CETCO Easy Roller™ GCL Deployment System is a preferred method of installing geosynthetic clay liners. Use of the Easy Roller system eliminates the need for spreader bars and heavy core pipes. Installation speed and worker safety are significantly increased. For further details, contact CETCO.

### **3 SHIPPING, UNLOADING & STORAGE**

- 
- 3.1** All lot and roll numbers should be recorded and compared to the packing list. Each roll of GCL should also be visually inspected during unloading to determine if any packaging has been damaged. Damage, whether obvious or suspected, should be recorded and the affected rolls marked.
- 3.2** Major damage suspected to have occurred during transit should be reported immediately to the carrier and to CETCO. The nature of the damage should also be indicated on the bill of lading with the specific lot and roll numbers. Accumulation of some moisture within roll packaging is normal and does not damage the product.
- 3.3** The party directly responsible for unloading the GCL should refer to this manual prior to shipment to ascertain the appropriateness of their unloading equipment and procedures. Unloading and on-site handling of the GCL should be supervised.
- 3.4** In most cases, CETCO GCLs are delivered on flatbed trucks. There are three methods of unloading: core pipe and spreader bar; slings; or stinger bar. To unload the rolls from the flatbed using a core pipe and spreader bar, first insert the core pipe through the core tube. Secure the lifting chains or straps to each end of the core pipe and to the spreader bar mounted on the lifting equipment. Hoist the roll straight up and make sure its weight is evenly distributed so that it does not tilt or sway when lifted.
- 3.5** At the customer's request, CETCO GCLs may be delivered with two 2" x 12' (50 mm x 3.65 m) Type V polyester endless slings on each roll. Before lifting, check the position of the slings. Each sling should be tied off in the choke position approximately one third (1/3) from the end of the roll. Hoist the roll straight up so that it does not tilt or sway when lifted.



- 3.6 In some cases, GCL rolls will be stacked in three pyramids on flatbed trucks. If slings are not used, rolls will require unloading with a stinger bar and extendible boom fork lift. Spreader bars will not work in this situation because of the limited access between the stacks of GCL. Three types of stingers are available from CETCO (Figures 2-4). To unload, guide the stinger through the core tube before lifting the GCL roll and removing from the truck.
- 3.7 An extendible boom fork lift with a stinger bar is required for unloading vans. Rolls in the nose and center of van should first be carefully pulled toward the door using the slings provided on the rolls.
- 3.8 Rolls should be stored at the job site away from high-traffic areas but sufficiently close to the active work area to minimize handling. The designated storage area should be flat, dry and stable. Moisture protection of the GCL is provided by its packaging; however, an additional tarpaulin or plastic sheet is recommended.
- 3.9 Rolls should be stacked in a manner that prevents them from sliding or rolling. This can be accomplished by chocking the bottom layer of rolls. Rolls should be stacked no higher than the height at which they can be safely handled by laborers (typically no higher than four layers of rolls). Rolls should never be stacked on end.

## 4

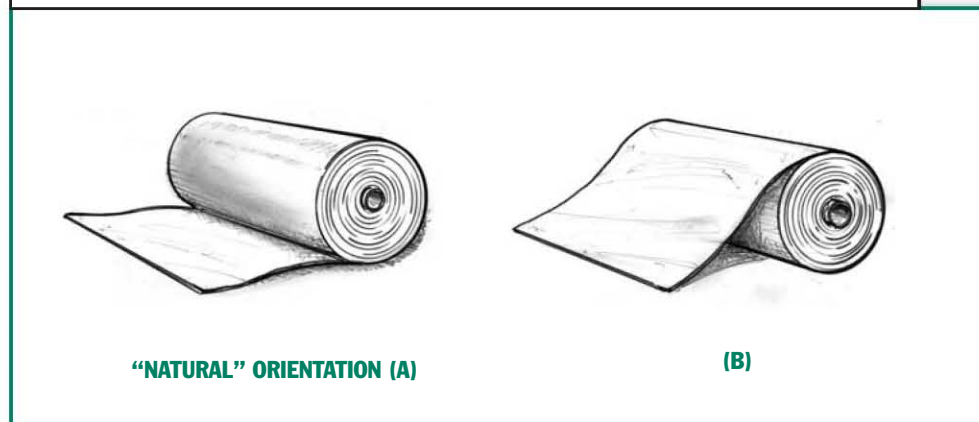
### SUBGRADE PREPARATION

- 4.1 Subgrade surfaces consisting of granular soils or gravel may not be acceptable due to their large void fraction and puncture potential. In high-head (greater than one foot or 30 cm) applications, subgrade soils should possess a particle size distribution such that at least 80 percent of the soil is finer than a #60 sieve (0.250 mm) unless a membrane-laminated GCL (Bentomat CL or Bentomat CLT) is used.
- 4.2 When the GCL is placed over an earthen subgrade, the subgrade surface must be prepared in accordance with the project specifications. The engineer's approval of the subgrade must be obtained prior to installation. The finished surface should be firm and unyielding, without abrupt elevation changes, voids, cracks, ice, or standing water.
- 4.3 The subgrade surface must be smooth and free of vegetation, sharp-edged rocks, stones, sticks, construction debris, and other foreign matter that could contact the GCL. The subgrade should be rolled with a smooth-drum compactor to remove any wheel ruts greater than 1 inch in depth, footprints, or other abrupt grade changes. Furthermore, all protrusions extending more than 0.5 inch (12 mm) from the subgrade surface shall be removed, crushed, or pushed into the surface with a smooth-drum compactor. The GCL may be installed on a frozen subgrade, but the subgrade soil in the unfrozen state should meet the above requirements.

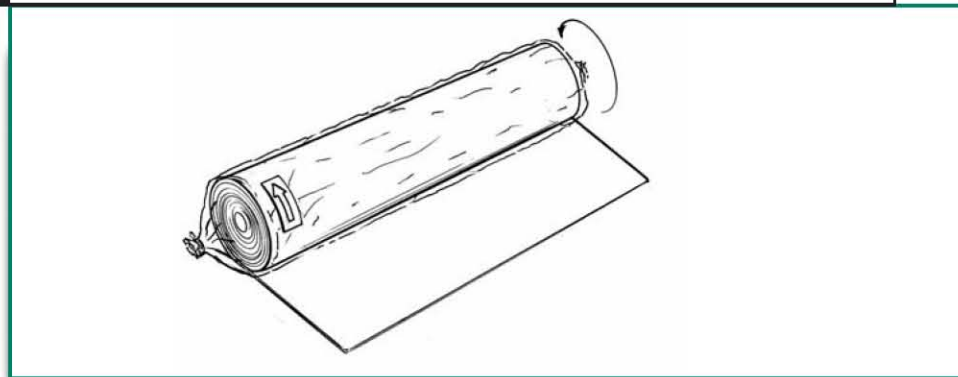


- 5.1 GCL rolls should be taken to the work area of the site in their original packaging. The orientation of the GCL (i.e., which side faces up) may be important if the GCL has two different types of geosynthetics. Check with the project engineer in order to determine if there is a preferred installation orientation for the GCL. If no specific orientation is required, allow the roll to unwind from the bottom rather than pulling from the top (Figure 5). The arrow sticker on the plastic sleeve indicates the direction the GCL will naturally unroll when placed on the ground (Figure 6). Prior to deployment, the packaging should be carefully removed without damaging the GCL.

**FIGURE 5 THE GCL CAN BE UNROLLED IN ITS “NATURAL” ORIENTATION (A) OR CAN BE PULLED FROM THE TOP OF THE ROLL (B)**



**FIGURE 6 DIRECTION TO UNROLL GCL ON GROUND PER FIGURE 5(A)**

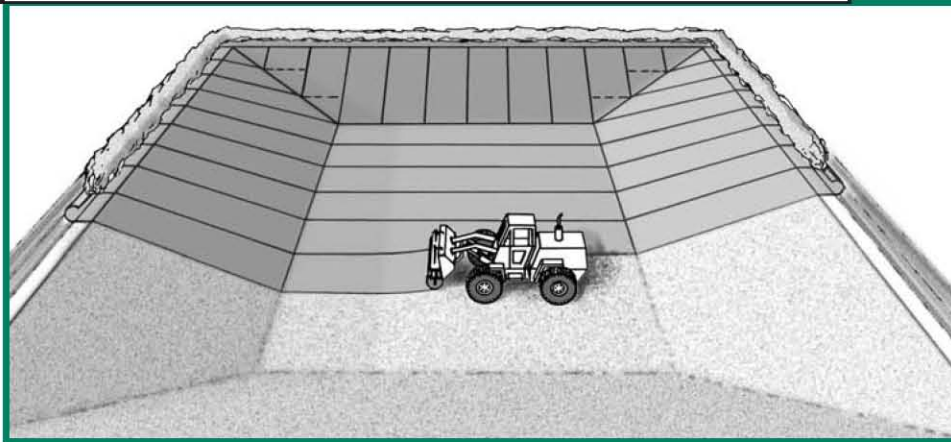


- 5.2 Equipment which could damage the GCL should not be allowed to travel directly on it. Acceptable installation, therefore, may be accomplished such that the GCL is unrolled in front of backwards-moving equipment (Figure 7). If the installation equipment causes rutting of the subgrade, the subgrade must be restored to its originally accepted condition before placement continues.



**FIGURE 7**

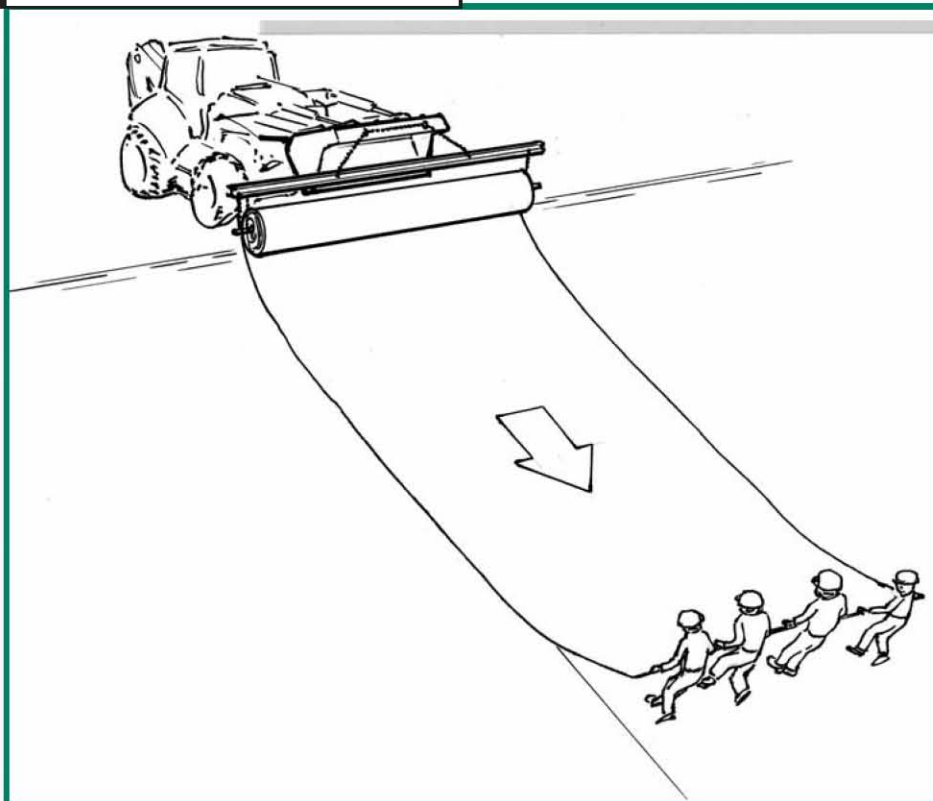
**TYPICAL BENTOMAT®/CLAYMAX® INSTALLATION TECHNIQUE**



- 5.3 If sufficient access is available, GCL may be deployed by suspending the roll at the top of the slope with a group of laborers pulling the material off of the roll and down the slope (Figure 8).
- 5.4 GCL rolls should not be released on the slope and allowed to unroll freely by gravity.
- 5.5 Care must be taken to minimize the extent to which the GCL is dragged across the subgrade in order to avoid damage to the bottom surface of the GCL. Care must also be taken when adjusting Bentomat CLT panels to avoid damage to the geotextile surface of one panel of GCL by the textured sheet of another panel of GCL. A temporary geosynthetic subgrade covering, commonly known as a slip sheet or rub sheet, may be used to reduce friction damage during placement.

**FIGURE 8**

**UNROLLING BENTOMAT**



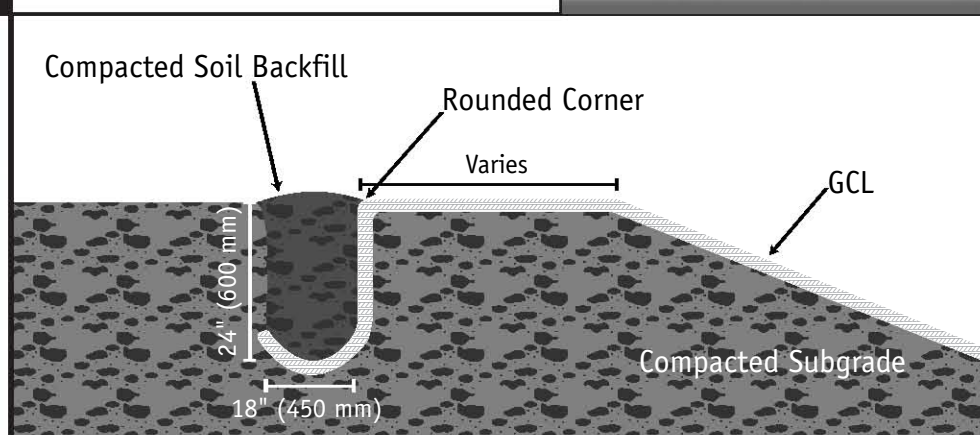


- 5.6 The GCL should be placed so that seams are parallel to the direction of the slope. End-of-panel seams should also be located at least 3 ft (1m) from the toe and crest of slopes steeper than 4H:1V. End-of-roll seams on slopes should be used only if the liner is not expected to be in tension.
- 5.7 All GCL panels should lie flat, with no wrinkles or folds, especially at the exposed edges of the panels. When Bentomat with SuperGroove® is repositioned, it should be gripped inside the SuperGroove by folding the edge.
- 5.8 The GCL should not be installed in standing water or during rainy weather. Only as much GCL shall be deployed as can be covered at the end of the working day with soil, geomembrane, or a temporary waterproof tarpaulin. The GCL shall not be left uncovered overnight. If the GCL is hydrated when no confining stress is present, it may be necessary to remove and replace the hydrated material. CETCO recommends that premature hydration be evaluated on a case-by-case basis. The project engineer, CQA inspector, and CETCO's TR-312 should be consulted for specific guidance if premature hydration occurs. The type of GCL, duration of exposure, degree of hydration, location in the liner system, and expected bearing loads should be considered. In many instances, a needlepunch reinforced GCL may not require removal/replacement if the following are true: (1) the geotextiles have not been separated, torn or otherwise damaged; (2) there is no evidence that the needlepunching between the two geotextiles has been compromised; (3) the Bentomat does not leave deep indentations when stepped upon; and (4) any overlapped seams with bentonite enhancement (see Section 7) are intact.
- 5.9 For the convenience of the installer, hash marks are placed on Bentomat every 5' (1.5 m) of length.

## 6 ANCHORAGE

- 6.1 If required by the project drawings, the end of the GCL roll should be placed in an anchor trench at the top of a slope. The front edge of the trench should be rounded to eliminate any sharp corners that could cause excessive stress on the GCL. Loose soil should be removed or compacted into the floor of the trench.

**FIGURE 9** TYPICAL ANCHOR TRENCH DESIGN







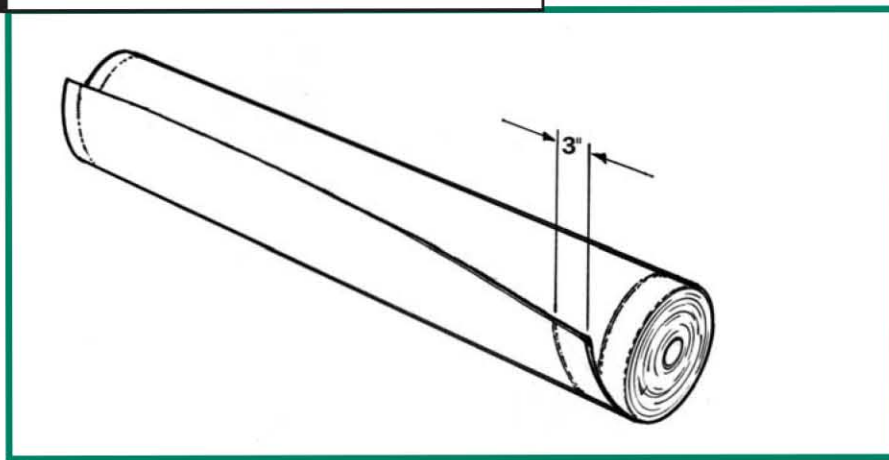
- 6.2 If a trench is used for anchoring the end of the GCL, soil backfill should be placed in the trench to provide resistance against pullout. The size and shape of the trench, as well as the appropriate backfill procedures, should be in accordance with the project drawings and specifications. Typical dimensions are shown in Figure 9.
- 6.3 The GCL should be placed in the anchor trench such that it covers the entire trench floor but does not extend up the rear trench wall.
- 6.4 Sufficient anchorage may alternately be obtained by extending the end of the GCL roll back from the crest of the slope, and placing cover soil. The length of this “runout” anchor should be prepared in accordance with project drawings and specifications.

## 7

### SEAMING

- 7.1 GCL seams are constructed by overlapping adjacent panel edges and ends. Care should be taken to ensure that the overlap zone is not contaminated with loose soil or other debris. Supplemental bentonite is not required for Claymax 200R. Bentomat ST, DN, and SDN with Supergroove® have self-seaming capabilities in their longitudinal overlaps (Figure 10) and do not require supplemental bentonite. For pond applications, supplemental bentonite must be used in longitudinal seams regardless of the CETCO GCL used.

**FIGURE 10** SUPERGROOVE

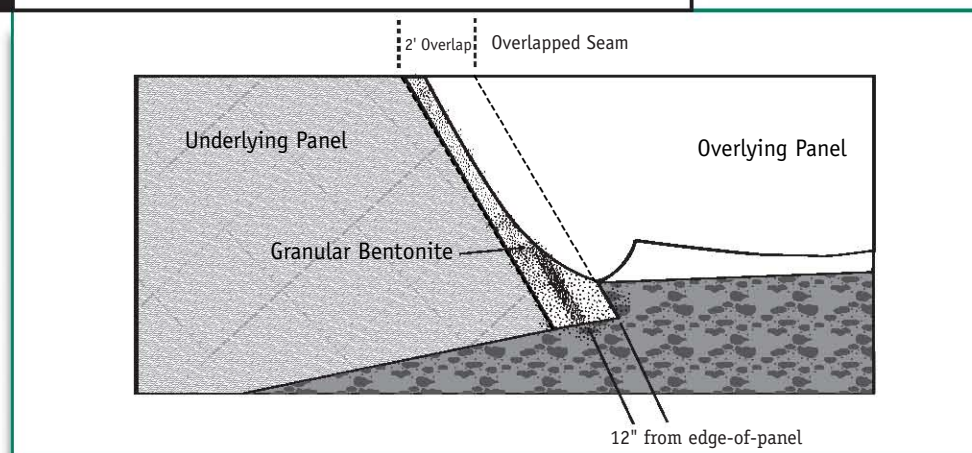


- 7.2 Longitudinal seams should be overlapped a minimum of 6 inches (150mm) for Bentomat and 12 inches (300mm) for Claymax.
- 7.3 End-of-panel overlapped seams should be overlapped 24 inches (600mm) for Bentomat and 48 inches (1,200mm) for Claymax.



- 7.4 End-of-panel overlapped seams are constructed such that they are shingled in the direction of the grade to prevent runoff from entering the overlap zone. End-of-panel seams on slopes are permissible, provided adequate slope stability analysis has been conducted (i.e., the GCL is not expected to be in tension). Bentonite-enhanced seams are required for all Bentomat end-of-panel overlapped seams.
- 7.5 Bentomat end-of-panel, bentonite-enhanced, overlapped seams are constructed first by overlapping the adjacent panels, exposing the underlying panel, and then applying a continuous bead or fillet of granular sodium bentonite 12" from the edge of the underlying panel (Figure 11). The minimum application rate at which the bentonite is applied is one-quarter pound per linear foot (0.4 kg/m).
- 7.6 If longitudinal bentonite enhanced seams are required, they are constructed first by overlapping the adjacent panels by a minimum 6-inches (150 mm), exposing the underlying edge and applying a continuous bead of granular bentonite approximately 3-inches (75 mm) from the edge. The minimum application rate for the granular bentonite is one quarter pound per linear foot (0.4 kg/m).

**FIGURE 11 BENTOMAT END-OF-PANEL OVERLAPPED SEAM**



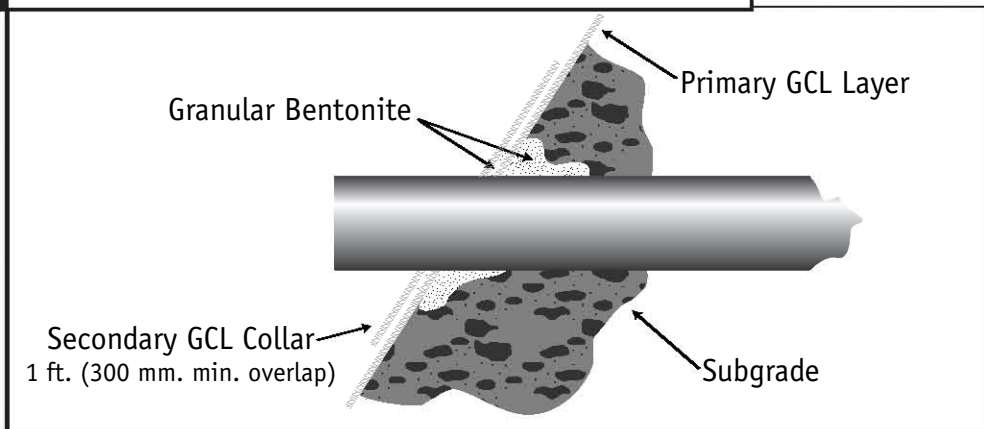
**8**

**SEALING AROUND PENETRATIONS AND STRUCTURES**

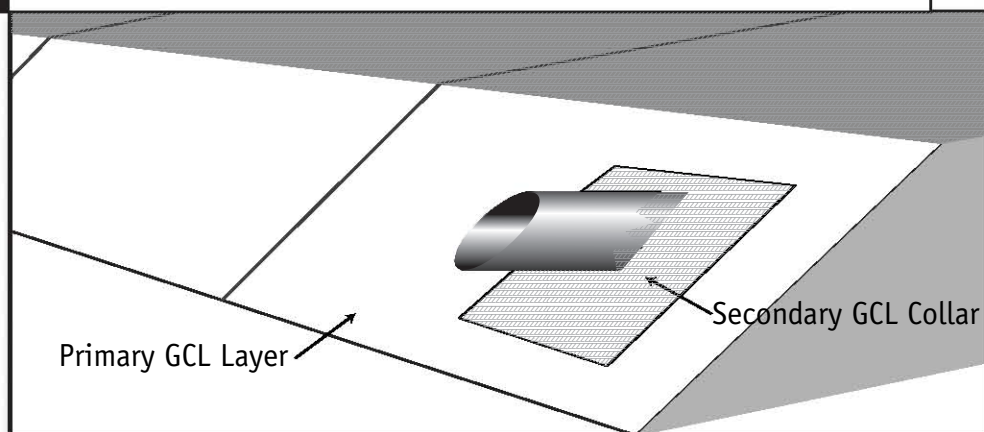
- 8.1 Cutting the GCL should be performed using a sharp utility knife. Frequent blade changes are recommended to avoid irregular tearing of the geotextile components of the GCL during the cutting process.
- 8.2 The GCL should be sealed around penetrations and structures embedded in the subgrade in accordance with Figures 12 through 14. Granular bentonite or a bentonite mastic shall be used liberally (approx. 2 lbs. /ln ft. or 3 kg/m) to seal the GCL to these structures.



**FIGURE 12A CROSS-SECTION OF A HORIZONTAL PIPE PENETRATION**

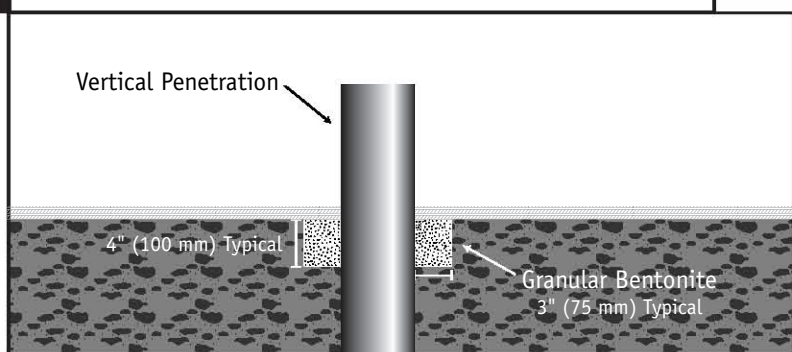


**FIGURE 12B ISOMETRIC VIEW OF A COMPLETED HORIZONTAL PIPE PENETRATION**



- 8.3 When the GCL is placed over a horizontal pipe penetration, a “notch” should be excavated into the subgrade around the penetration (Figure 12a). The notch should then be backfilled with granular bentonite. A secondary collar of GCL should be placed around the penetration as shown in Figure 12b. It is helpful to first trace an outline of the penetration on the GCL and then cut a “star” pattern in the collar to enhance the collar’s fit to the penetration. Granular bentonite should be applied between the primary GCL layer and the secondary GCL collar.

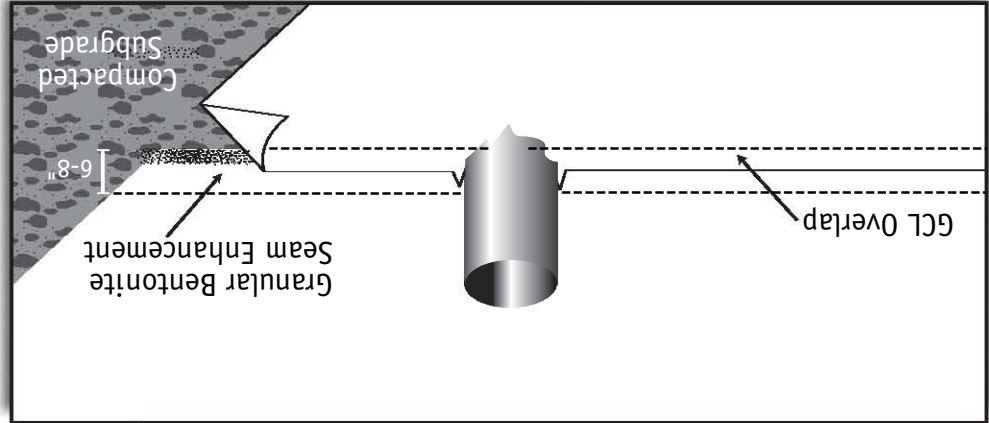
**FIGURE 13A CROSS-SECTION OF A VERTICAL PENETRATION**





**FIGURE 14** CROSS-SECTION OF GCL SEAL AGAINST AN EMBEDDED STRUCTURE OR WALL

8.5 When the GCL is terminated at a structure or wall that is embedded into the subgrade on the floor of the containment area, the subgrade should be notched as described in Sections 8.3 and 8.4. The notch is filled with granular bentonite, and the GCL should be placed over the notch and up against the structure (Figure 14). Connection to the structure can be accomplished by placement of soil or stone backfill in this area. When structures or walls are at the top of a slope, additional detailing may be required. Contact CETCO for specific guidance.



**FIGURE 13B** ISOMETRIC VIEW OF THE COMPLETED VERTICAL PENETRATION

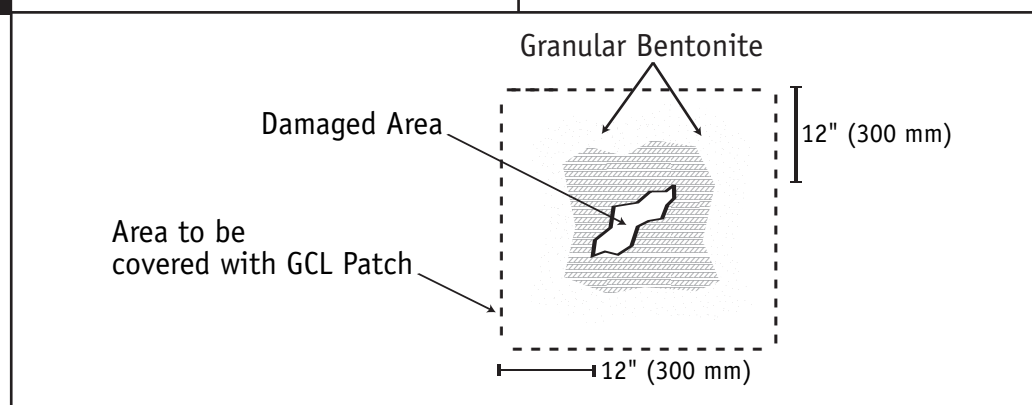
8.4 Vertical penetrations are prepared by notching into the subgrade as shown in Figure 13a. The penetration can be completed with two separate pieces of GCL as shown in Figure 13b. Alternatively, a secondary collar can be placed as in Figure 12a or 12b.



## DAMAGE REPAIR

- 9.1 If the GCL is damaged (torn, punctured, perforated, etc.) during installation, it may be possible to repair it by cutting a patch to fit over the damaged area (Figure 15). The patch should be cut to size such that a minimum overlap of 12 inches (300 mm) is achieved around all parts of the damaged area. Granular bentonite or bentonite mastic should be applied around the damaged area prior to placement of the patch. It may be necessary to use an adhesive such as wood glue to affix the patch in place so that it is not displaced during cover placement. Smaller patches may be tucked under the damaged area to prevent patch movement.

**FIGURE 15** DAMAGE REPAIR BY PATCHING



## 10 COVER PLACEMENT

- 10.1 The final thickness of soil cover on the GCL varies with the application. A minimum cover layer must be at least 1 foot (300 mm) thick to provide confining stress to the GCL, eliminate the potential for seam separation and prevent damage by equipment, erosion, etc.
- 10.2 Cover soils should be free of angular stones or other foreign matter that could damage the GCL. Cover soils should be approved by the Engineer with respect to particle size, uniformity, and chemical compatibility. Consult CETCO if cover soils with high concentrations of calcium (e.g., limestone, dolomite, gypsum, seashell fragments) are present.
- 10.3 Recommended cover soils should have a particle size distribution ranging between fines and 1 inch (25 mm), unless a cushioning geotextile is specified.
- 10.4 Soil cover shall be placed over the GCL using construction equipment that minimizes stresses on the GCL. A minimum thickness of 1 foot (300 mm) of cover soil should be maintained between the equipment tires/tracks and the GCL at all times during the covering process. In frequently high-traffic areas or roadways, a minimum thickness of 2 feet (600 mm) is required.
- 10.5 Soil cover should be placed in a manner that prevents the soil from entering the GCL overlap zones. Soil cover should be pushed up slopes, not down slopes, to minimize tensile forces on the GCL.



- 10.6** When a textured geomembrane is installed over the GCL, a temporary geosynthetic covering known as a slip sheet or rub sheet should be used to minimize friction during placement and to allow the textured geomembrane to be more easily moved into its final position.
- 10.7** Claymax must be covered with a geomembrane and/or 12" (300 mm) of cover material within 8 hours of deployment to prevent the potential for shrinkage by desiccation.
- 10.8** Cyclical wetting and drying of GCL covered only with geomembrane can cause overlap separation. Soil cover should be placed promptly whenever possible. Geomembranes should be covered with a white geotextile and/or operations layer without delay to minimize the intensity of wet-dry cycling. If there is the potential for unconfined cyclic wetting and drying over an extended period of time, the longitudinal seam overlaps should be increased based on the project engineer's recommendations.
- 10.9** To avoid seam separation, the GCL should not be put in excessive tension by the weight or movement of textured geomembrane on steep slopes. If there is the potential for unconfined geomembrane expansion and contraction over an extended period of time, the longitudinal seam overlaps should be increased based upon the project engineer's recommendations.

## 11

### HYDRATION

- 11.1** Hydration is usually accomplished by natural rainfall and/or absorption of moisture from soil. However, in cases where the containment of non-aqueous liquid is required, it may be necessary to hydrate the covered GCL with water prior to use.
- 11.2** If manual hydration is necessary, water can be introduced by flooding the covered lined area or using a sprinkler system.
- 11.3** If the GCL is hydrated when no confining stress is present, it may be necessary to remove and replace the hydrated material. As discussed in Section 5.8, in many instances, a needlepunch reinforced GCL may not require removal/replacement if the following are true: (1) the geotextiles have not been separated, torn, or otherwise damaged; (2) there is not evidence that the needlepunching between the two geotextiles has been compromised; (3) the Bentomat does not leave deep indentations when stepped upon, and (4) any overlapped seams with bentonite enhancement (see Section 7) are intact.





# Geosynthetic Clay Liners (GCL's)



Geosynthetic Clay Liners (GCL's) are high performance environmental liners used in environmental containment applications. GCL's consist of two layers of geotextiles surrounding a layer of low permeability sodium bentonite that are needle punched together to increase internal shear resistance. The geotextiles offer a long lasting resistance to physical or chemical break-down in harsh elements, while the bentonite's high swelling capacity and low permeability provide an effective hydraulic seal.



GCL's provide an excellent alternative to conventional compacted clay liners by replacing a thick section of compacted clay with a thin layer of pure sodium bentonite. One truckload of GCL is equivalent to 150 truckloads of compacted clay. Benefits include easy installation, better hydraulic performance, and resistance to varying weather conditions.

## Typical Lining Applications

- Canals, Stormwater Impoundments, and Wetlands
- Highway and Civil
- Landfill Liners
- Landfill Caps
- Mining
- Ponds
- Secondary Containment

# Geosynthetic Clay Liners (GCL's)

## Product Specifications

Material Property	Test Method	Test Frequency m <sup>2</sup> (ft <sup>2</sup> )	Bentomat® ST	Bentomat® DN
Bentonite Swell Index <sup>1</sup>	ASTM D 5890	1 per 50 tonnes	24 ml/2 g min	24 ml/2g min
Bentonite Fluid Loss <sup>1</sup>	ASTM D 5891	1 per 50 tonnes	18 ml max	18 ml max
Bentonite Mass/Area <sup>2</sup>	ASTM D 5993	4,000 (40,000)	3.6 kg/m <sup>2</sup> min (0.75 lb/ft <sup>2</sup> )	3.6 kg/m <sup>2</sup> min (0.75 lb/ft <sup>2</sup> )
GCL Grab Strength <sup>3</sup>	ASTM D 6768	20,000 (200,000)	53 N/cm MARV (30 lbs/in MARV)	88 N/cm (MARV) (50 lbs/in MARV)
GCL Peel Strength <sup>3</sup>	ASTM D 6496	4,000 (40,000)	6.1 N/cm min (3.5 lbs/in)	6.1 N/cm min (3.5 lbs/in)
GCL Index Flux <sup>4</sup>	ASTM D 5887	Weekly	1 x 10 <sup>-8</sup> m <sup>3</sup> /m <sup>2</sup> /sec max	1 x 10 <sup>-8</sup> m <sup>3</sup> /m <sup>2</sup> /sec max
GCL Hydraulic Conductivity <sup>4</sup>	ASTM D 5887	Weekly	5 x 10 <sup>-9</sup> cm/sec max	5 x 10 <sup>-9</sup> cm/sec max
GCL Hydrated Internal Shear Strength <sup>5</sup>	ASTM D 5321 ASTM D 6243	Periodic	500 psf (24 kPa) Typ 200 psf	500 psf (24 kPa) Typ 200 psf

*Bentomat ST is a reinforced GCL consisting of a layer of sodium bentonite between a woven and a nonwoven geotextile, which are needle punched together. Bentomat DN is a reinforced GCL consisting of a layer of sodium bentonite between two nonwoven geotextiles, which are needle punched together.*

### Notes

- 1 Bentonite property tests performed at a bentonite processing facility before shipment to CETCO's GCL production facilities.
- 2 Bentonite mass/area reported at 0 percent moisture content.
- 3 All tensile strength testing is performed in the machine direction using ASTM D 6768. All peel strength testing is performed using ASTM D6496. Upon request, tensile and peel results can be reported per modified ASTM D 4632 using 4 inch grips.
- 4 Index flux and permeability testing with deaired distilled/deionized water at 80 psi (551kPa) cell pressure, 77 psi (531 kPa) headwater pressure and 75 psi (517 kPa) tailwater pressure. Reported value is equivalent to 925 gal/acre/day. This flux value is equivalent to a permeability of 5x10<sup>-9</sup> cm/sec for typical GCL thickness. Actual flux values vary with field condition pressures. The last 20 weekly values prior the end of the production date of the supplied GCL may be provided.
- 5 Peak values measured at 200 psf (10 kPa) normal stress for a specimen hydrated for 48 hours. Site-specific materials, GCL products, and test conditions must be used to verify internal and interface strength of the proposed design.

CETCO has developed an edge enhancement system (SuperGroove™) that eliminates the need to use additional granular sodium bentonite within the overlap area of the seams. It comes standard on both longitudinal edges of Bentomat® ST. It should be noted that SuperGroove™ does not appear on the end-of-roll overlaps and recommend the continued use of supplemental bentonite for all end-of-roll seams.

*Disclaimer: The information provided by Nilex is believed to be correct and is generally based on information supplied by the manufacturers of the product offered. Any recommendations made by Nilex concerning uses or applications of our products are also believed to be reliable; however, as Nilex has no control over design execution, and field conditions of the project which incorporate the product. Nilex disclaims all warranties, expressed or implied, including, without limitation, the warranties of merchantability and/or fitness for a particular purpose.*

[nilex.com](http://nilex.com)





## Appendix C

- Geotechnical Report Prepared by Carlson
- Impervious Storm Facility Letter by Carlson

# Carlson Geotechnical

A division of Carlson Testing, Inc.  
Phone: (503) 601-8250  
Fax: (503) 601-8254

Bend Office (541) 330-9155  
Eugene Office (541) 345-0289  
Salem Office (503) 589-1252  
Tigard Office (503) 684-3460



**Report of  
Preliminary Geotechnical Investigation, Site-Specific  
Seismic Hazards Study & Infiltration Testing  
Sunset Primary School  
2351 Oxford Street  
West Linn, Oregon**

**CGT Project Number G1504201**

Prepared for

West Linn Wilsonville School District 3JT  
Attn: Mr. Remo Douglas  
2755 SW Borland Road  
Tualatin, OR 97062

July 15, 2015

# Carlson Geotechnical

A division of Carlson Testing, Inc.  
Phone: (503) 601-8250  
Fax: (503) 601-8254

Bend Office (541) 330-9155  
Eugene Office (541) 345-0289  
Salem Office (503) 589-1252  
Tigard Office (503) 684-3460



July 15, 2015

West Linn Wilsonville School District 3JT  
Attn: Mr. Remo Douglas  
2755 SW Borland Road  
Tualatin, Oregon 97062

**Report of  
Preliminary Geotechnical Investigation, Infiltration Testing &  
Site-Specific Seismic Hazards Study  
Sunset Primary School  
2351 Oxford Street  
West Linn, Oregon**

CGT Project Number G1504201

Dear Mr. Douglas:

Carlson Geotechnical (CGT), a division of Carlson Testing, Inc. (CTI), is pleased to submit this report summarizing the results of our preliminary geotechnical investigation, infiltration testing, and site-specific seismic hazards study (SSSHS), for the proposed new Sunset Primary School project. The site is located at 2351 Oxford Street in West Linn, Oregon. We performed our work in general accordance with CGT Proposal GP6676, dated May 18, 2015. Written authorization for our services was received on May 29, 2015.

We appreciate the opportunity to work with you on this project. Please contact us at 503.601.8250 if you have any questions regarding this report.

Respectfully Submitted,  
**CARLSON GEOTECHNICAL**



Jeffrey P. Quinn, P.E.  
Geotechnical Engineer  
[jquinn@carlsontesting.com](mailto:jquinn@carlsontesting.com)



Ryan Houser, R.G., CEG  
Senior Engineering Geologist  
[rhouser@carlsontesting.com](mailto:rhouser@carlsontesting.com)

Doc ID: G:\GEOTECH\PROJECTS\2015 Projects\New Sunset Primary School\008 - Deliverables\Report Files\Report G1504201.docx

**TABLE OF CONTENTS**

**1.0 INTRODUCTION..... 4**

**1.1 Project Information ..... 4**

**1.2 Scope of Services ..... 5**

**2.0 SITE DESCRIPTION..... 5**

**2.1 Site Geology ..... 5**

**2.2 Site Surface Conditions..... 6**

**3.0 FIELD INVESTIGATION ..... 6**

**3.1 Test Pits ..... 6**

**3.2 Pavement Cores ..... 6**

**3.3 Machine-Drilled Borings..... 7**

**3.4 Infiltration Testing..... 7**

**3.5 Soil Classification & Sampling ..... 8**

**4.0 LABORATORY TESTING ..... 8**

**5.0 SUBSURFACE CONDITIONS..... 8**

**5.1 Soils/Materials ..... 8**

**5.2 Groundwater ..... 9**

**6.0 SITE SPECIFIC SEISMIC HAZARDS STUDY ..... 10**

**6.1 Overview ..... 10**

**6.2 Seismic Ground Motion Values ..... 10**

**7.0 GEOTECHNICAL REVIEW & DISCUSSION ..... 10**

**8.0 PRELIMINARY RECOMMENDATIONS..... 11**

**8.1 Site Preparation..... 11**

**8.2 Temporary Excavations..... 13**

**8.3 Wet Weather Considerations ..... 14**

**8.4 Structural Fill ..... 15**

**8.5 Permanent Slopes ..... 17**

**8.6 Shallow Foundations ..... 18**

**8.7 Rigid Retaining Walls ..... 19**

**8.8 Floor Slabs..... 20**

**8.9 Flexible Pavements..... 21**

**8.10 Rigid (Concrete) Pavements ..... 23**

**8.11 Additional Considerations ..... 24**

**9.0 RECOMMENDED ADDITIONAL SERVICES..... 24**

**9.1 Design Review ..... 24**

**9.2 Observation of Construction ..... 24**

**10.0 LIMITATIONS ..... 25**

**ATTACHMENTS**

Site Location ..... Figure 1

Site Plan ..... Figure 2

Site Photographs..... Figure 3

Soil Classification Criteria & Terminology ..... Figure 4

Test Pit Logs ..... Figures 5 through 14

Pavement Core Logs ..... Figures 15 and 16

Boring Logs ..... Figures 17 through 20

Fill Slope Detail ..... Figure 21

Retaining Wall Pressure Distribution ..... Figure 22

Results of Infiltration Testing..... Appendix A

Site-Specific Seismic Hazards Study..... Appendix B

## 1.0 INTRODUCTION

Carlson Geotechnical (CGT), a division of Carlson Testing, Inc. (CTI), is pleased to submit this report summarizing the results of our preliminary geotechnical investigation, infiltration testing, and site-specific seismic hazards study (SSSHS) for the proposed new Sunset Primary School project. The project site is located at 2351 Oxford Street in West Linn, Oregon, as shown on the attached Site Location, Figure 1.

This report is considered preliminary, as we have not reviewed final grading plans, finished floor elevations, and/or detailed structural information for the development. An addendum indicating that this report is final, and including supplemental recommendations, if warranted, can be issued after we have reviewed those items.

### 1.1 Project Information

CGT developed an understanding of the proposed project based on our correspondence and review of the provided, "Design Concept – New Sunset Primary School", prepared by Dull Olson Weekes – IBI Group Architects, Inc (DOW), and dated April 10, 2015. We understand the project is in the preliminary stages of planning, but will likely include the following:

- Demolition of the existing Sunset Primary School and appurtenant parking lot and drive lane areas. We understand demolition activities will take place once the new Sunset Primary School has been constructed.
- Construction of a new two-story, approximately 28,000 square-foot, primary school within the east portion of the site, as shown on the attached Site Plan (Figure 2). Although no architectural information has been provided, we anticipate the building will be steel- and/or concrete-framed and incorporate a slab-on-grade first floor. We understand a daylight basement is being considered at the southeast portion of the building. Although no structural loading information has been provided, we have assumed maximum column, continuous wall, and uniform floor slab loads will be on the order of 150 kips, 4 kips per lineal foot (klf), and 200 pounds per square foot (psf), respectively.
- We understand the building will be classified as a "Special Occupancy Structure" per Oregon Revised Statutes (ORS) 455.447. Accordingly, the building will be assigned as Risk Category III per Table 1604.5 of the 2014 Oregon Structural Specialty Code (OSSC), and a site-specific seismic hazard study (SSSHS) is required as part of the geotechnical report per Section 1803.2 of the OSSC.
- Construction of a school bus pick-up/drop-off area, drive lanes, and passenger car parking within the west portion of the site. We understand loading docks and fire lanes for heavy trucks are also being proposed. Although no civil plans have been provided, we anticipate new pavements will be surfaced with asphaltic concrete (AC) and the loading dock areas will be surfaced with Portland Cement Concrete (PCC) pavement.
- Installation of appurtenant underground utilities to serve the new building.
- The existing topographic relief across the proposed building area is approximately 10 feet. Therefore, we anticipate permanent grade changes at the site may be up to about 5 feet (i.e., maximum cut and fill depth). We anticipate the maximum cut required to facilitate construction of the daylight basement at the southeast portion of the building will be on the order of about 8 feet.
- We understand the project civil engineer (KPFF) is evaluating the feasibility of on-site stormwater infiltration for disposal of stormwater collected from hard surfaces. KPFF previously requested

infiltration testing in seven locations across the site as part of our field exploration. Design of on-site stormwater infiltration facilities will rest with others.

## 1.2 Scope of Services

Our scope of work included the following:

- Contact the Oregon Utilities Notification Center to mark the locations of public utilities within a 30-foot radius of our explorations at the site. CGT also subcontracted a private utility locating service to mark the locations of public and private utilities within a 30-foot radius of our explorations.
- Explore subsurface conditions at the site with the following field exploration program:
  - Excavate ten test pits to depths up to about 10 feet bgs.
  - Advance two pavement cores through the existing asphaltic concrete (AC) pavement and conducting dynamic cone penetrometer (DCP) tests on the exposed pavement subgrade.
  - Advance four machine-drilled borings to depths ranging from about 5 to 61 feet below ground surface (bgs).
  - Perform six infiltration tests at the site in general accordance with the Encased Falling Head Test procedure described in Appendix F.2 of the January 2014 City of Portland “Portland Stormwater Management Manual”. Results of our infiltration testing are presented in the attached Appendix A.
- Classify the materials encountered in the borings in general accordance with American Society for Testing and Materials (ASTM) D2488 (Visual-Manual Procedure).
- Collect representative, disturbed and relatively undisturbed samples of the soils encountered within the explorations in order to perform laboratory testing and to confirm our field classifications.
- Provide a technical narrative describing surface and subsurface deposits, and local geology of the site, based on the results of our explorations and published geologic mapping.
- Provide preliminary geotechnical recommendations for site preparation and earthwork.
- Provide preliminary geotechnical engineering recommendations for design and construction of shallow spread foundations and concrete floor slabs.
- Provide preliminary geotechnical engineering recommendations for design and construction of flexible (asphaltic concrete) and rigid (concrete) pavements.
- Conduct a Site-Specific Seismic Hazards Study (SSSHS) in general accordance with the requirements of Section 1803.3.2 of the 2014 Oregon Structural Specialty Code (OSSC). The results of the SSSHs are presented in the attached Appendix B.
- Provide this written report summarizing the results of our geotechnical investigation, infiltration testing, site-specific seismic hazards study and recommendations for the project.

## 2.0 SITE DESCRIPTION

### 2.1 Site Geology

The site is located at the southeast end of the Tualatin Mountains. The Tualatin Mountains separate the Tualatin Valley to the east, the Portland Basin to the northeast, and the Willamette Valley to the southwest. Based on available geologic mapping<sup>1</sup> of the area, the site is underlain by Columbia River Basalt. The Columbia River Basalt consists of numerous fine-grained lava flows that primarily erupted

---

<sup>1</sup> Madin, I.P., 2009, Geologic map of the Oregon City 7.5' quadrangle, Clackamas County, Oregon: Oregon Department of Geology and Mineral Industries, Geological Map Series 119, scale 1:24,000.

from fissures in eastern Washington and Oregon and western Idaho during the Miocene (23.8 to 5.3 million years ago). A thick, clay-rich residual soil often forms on the upper portion of the Columbia River Basalt from the in-place weathering of the rock. The Columbia River Basalt is several thousand feet thick in the vicinity of the site

## **2.2 Site Surface Conditions**

The approximate 6¼-acre site, consisting of five adjacent tax lots, is bordered by Oxford Street and Sunset Park to the south, a forested area to the east, and residential development to the north and west. The existing Sunset Primary School is situated on the western portion of the site. The new school structure will be located on the east and southeast portions of the site. The site is generally level in the vicinity of the existing school structure and playground/baseball field. The site descends gently to the southeast from the east end of the baseball field. The southeast portion of the new structure will be located in an undeveloped, forested area between the baseball field and Sunset Park. The existing site conditions and topography, as well as the existing and proposed school footprints are shown on the attached Site Plan, Figure 2. Photographs of the site taken at the time of our investigation are shown on the attached Figure 3.

## **3.0 FIELD INVESTIGATION**

CGT completed the field investigation between June 18 and June 26, 2015. The field investigation consisted of ten test pits, two pavement cores, four machine-drilled borings, and six infiltration tests. The approximate exploration locations are shown on the attached Site Plan, Figure 2. The exploration locations shown therein were determined based on measurements from existing site features (property corners, etc.) and should be considered approximate.

### **3.1 Test Pits**

CGT excavated ten test pits (TP-1 through TP-10) at the site on June 18, 2015. The test pits were excavated to depths ranging from 4 to about 10 feet bgs using a Case CX-55B mini-excavator with a 24-inch wide toothed bucket, and were loosely backfilled with cuttings upon completion.

Pocket penetrometer readings were taken within the upper 4 feet of the test pits. The pocket penetrometer is a hand-held instrument that provides an approximation of the unconfined compressive strength of cohesive, fine-grained soils. The correlation between pocket penetrometer readings and the consistency of cohesive, fine-grained soils is provided on the attached Figure 4.

### **3.2 Pavement Cores**

Two pavement cores (C-1 and C-2) were advanced at the site on June 19, 2015. The cores were advanced using a pavement coring drill equipped with a 6-inch diameter pavement coring barrel, provided and operated by CTI. At pavement core C-1, the base rock was excavated using a rotary hammer drill to expose the underlying native subgrade soil. Once the subgrade soil was exposed, a dynamic cone penetrometer (DCP) test was conducted (as described below). Upon completion of the DCP test, a 3-inch diameter hand auger was used to advance to a depth of about 1 foot bgs, for the purpose of collecting a bulk sample of the subgrade soil.

At pavement core C-2, the base rock was encountered to a depth of about 22 inches bgs, the practical limit to which the rotary hammer could advance. Therefore, CGT was unable to expose the subgrade soil

and conduct a DCP test. Upon completion of exploration, both pavement cores were patched with cold patch asphalt.

In conjunction with pavement core hole C-1, and following removal of the asphalt pavement and underlying base rock (i.e., on top of the exposed subgrade soil), we performed dynamic cone penetrometer tests to depths of up to about 5½ feet bgs. This test was performed using a Wildcat Dynamic Cone Penetrometer (WDCP) provided and operated by CGT. The WDCP test consists of driving 1.1-inch diameter, steel rods with a 1.4-inch diameter, cone tip into the ground using a 35-pound drop hammer with a 15-inch, free-fall height. The number of blows required to drive the steel rods is recorded for each 10 centimeters (3.94 inches) of penetration. The blow count for each interval is then converted to the corresponding Standard Penetration Test (SPT) “N60” values, which are used to estimate the soil relative consistency for cohesive soils, or relative density for non-cohesive soils. Results of the WDCP test are presented on the log of pavement core hole C-1 (Figure 15).

### **3.3 Machine-Drilled Borings**

Borings B-1 through B-3 were advanced to depths ranging from about 21 to 61 feet bgs on June 26, 2015, using mud-rotary drilling techniques with a CME-75HT truck-mounted drill rig. Boring B-4 was advanced on June 22, 2015 to a depth of about 5 feet bgs, using hollow-stem auger drilling techniques with a WS45, limited access track-mounted drill rig. Both drill rigs were provided and operated by our subcontractor, Western States Soil Conservation of Hubbard, Oregon. Upon completion, the borings were backfilled with granular bentonite. The surface at boring B-4 was patched with cold-patch asphalt.

Standard Penetration Tests (SPTs) were conducted within borings B-1 through B-3 (drilled with the CME-75HT drill rig) using a split-spoon sampler in general accordance with ASTM D1586. The SPT is performed by driving a 2-inch, outside-diameter, split-spoon sampler into the undisturbed formation located at the bottom of the advanced boring with repeated blows of a 140 pound, automatic hammer falling a vertical distance of 30 inches. The number of blows (N-value) required to drive the sampler the last 12 inches of an 18-inch sample interval is used to characterize the soil consistency or relative density. The SPTs were conducted at 2½- to 5-foot intervals to the termination depths of the borings.

The CME-75HT drill rig was equipped with a 140-pound, automatic hammer, which was used to conduct the SPTs. It should be noted automatic hammers generally produce lower SPT values than those obtained using a traditional safety hammer (cathead). According to the driller, the automatic hammer on the CME-75HT drill rig had hammer efficiency ( $ETR_{\text{hammer}}$ ) of 85.0 percent, resulting in an efficiency factor of about 1.4. We have considered this in our description of soil relative density and in our evaluation of soil strength and compressibility. Field SPT “raw” values that have not been adjusted for hammer efficiency, as well as  $N_{60}$  values that have been adjusted for hammer efficiency, are listed on the attached boring logs.

### **3.4 Infiltration Testing**

CGT performed six infiltration tests (IT-1 through IT-6) at the site on June 18 and June 22, 2014, in test pits and borings advanced for that purpose. The locations of the infiltration tests are shown on the Site Plan (Figure 2), and the results of the infiltration tests are presented in the attached Appendix A.



### **3.5 Soil Classification & Sampling**

Soil samples were obtained at selected intervals during excavation of the test pits and pavement cores. Soil samples were also obtained at selected intervals in the drilled borings using the referenced split-spoon (SPT) sampler and thin-walled, steel (Shelby) tube samplers. All soil samples collected at the site were stored in sealable plastic bags and were transported to our laboratory for further examination and testing. Our geotechnical staff visually examined all samples returned to our laboratory in order to refine the initial field classifications.

### **4.0 LABORATORY TESTING**

Laboratory testing was performed on samples collected in the field to refine our initial field classifications and determine in-situ parameters. Laboratory testing included thirty-seven moisture content determinations (ASTM D2216), three Atterberg limits (plasticity) tests (ASTM D4318), and three fines content determinations (ASTM D1140). Results of the laboratory tests are shown on the respective boring logs.

### **5.0 SUBSURFACE CONDITIONS**

Logs of the explorations are presented on the attached Exploration Logs, Figures 5 through 20. Surface elevations indicated on the logs were estimated based on available topographic mapping on Metro's GIS website<sup>2</sup>. Elevations shown on the logs should be considered approximate.

#### **5.1 Soils/Materials**

The following describes each of the subsurface materials encountered at the site.

*Asphaltic Concrete Pavement:* Asphaltic concrete (AC) pavement was encountered at the surface of drilled boring B-4 and pavement cores C-1 and C-2. We measured respective AC pavement thicknesses of 3¾ inches, 4¼ inches, and 5 inches at B-4, C-1, and C-2.

*Undocumented Gravel Fill (GP FILL):* Undocumented gravel fill (base rock) was encountered below the asphaltic concrete pavement in drilled boring B-4 and in pavement cores C-1 and C-2 and extended to depths of about ¾- to 2 feet bgs. Undocumented fill refers to materials placed without (available) records of subgrade conditions or evaluation of compaction. The gravel fill was generally gray, moist, fine- to coarse-grained (up to about ¾-inch diameter), and angular. Some sub-rounded gravel up to about 3 inches in diameter was observed in B-4 and C-1. The gravel fill was relatively well-graded based on visual examination of samples and drill cuttings.

*Organic Silt Topsoil (OL FILL):* Organic silt topsoil fill was encountered at the surface of all explorations with the exception of TP-7, B-4, C-1, and C-2. The organic silt topsoil extended to depths ranging from about 4 to 6 inches bgs and was generally very stiff, brown, damp to moist, exhibited low plasticity, and contained abundant fine rootlets (typically less than ¼-inch in diameter).

*Lean Clay Fill (CL Fill):* Undocumented lean clay fill was encountered at the surface of test pit TP-3 and below the topsoil in test pits TP-1, TP-3, TP-4, and boring B-2. The lean clay fill and extended to depths

---

<sup>2</sup> <https://gis.oregonmetro.gov/metromap/>

ranging from about 1½ to 2½ feet bgs and was generally stiff to very stiff, brown, moist, contained variable amounts of gravel, and exhibited low plasticity.

*Drain Rock Fill (GP FILL):* Drain rock fill (GP FILL) was encountered below the lean clay fill in test pits TP-1 and TP-3, surrounding a 3-inch diameter perforated drain pipe. The drain rock fill extended to a depth of about 1¾ feet bgs and was generally gray, open-graded, fine- to coarse-grained (up to about 1-inch diameter), and sub-rounded.

*Residual Soils (CL-CH):* Residual soils were encountered below the topsoil or fill in each exploration, with the exception of C-2, which did not advance through the gravel fill. The residual soils generally consisted of lean to fat clay (CL-CH), extending to depths ranging from about 3 to 7 feet bgs. The residual soils extended to the maximum depths explored in pavement core C-1, boring B-4, and test pits TP-6, TP-7, TP-8, and TP-10 (from about 1 foot to 5 feet bgs). The residual soils were typically very stiff, brown to orange-brown, moist, exhibited moderate to high plasticity, and contained occasional fine to coarse gravel-sized nodules of hard clay.

*Decomposed Volcaniclastics (CL and SC):* Decomposed volcaniclastics were encountered below the residual soils and extended to the full depths explored (up to about 61 feet bgs). The decomposed volcaniclastics typically consisted of sandy lean clay (CL), sandy lean clay with gravel (CL), gravelly clay (CL), and clayey sand (SC). The decomposed volcaniclastics were typically very stiff to hard, varicolored (brown, red-brown, black and gray), exhibiting moderate plasticity, contained variable amounts of sand and gravel, and generally consisted of a blocky structure with an apparent decomposed rock fabric.

## **5.2 Groundwater**

We did not encounter groundwater within the depths explored at the site between June 18 and 22, 2015. Borings B-1 through B-3 were advanced using the mud rotary drilling technique, which precludes direct observation of groundwater during drilling. However, we did observe occasional zones of wet/saturated soil samples from about 5¼ to 10 feet bgs in borings B-1 and B-2, which may be representative of perched groundwater. We did not observe any seepage or perched groundwater in the test pit explorations. To approximate groundwater levels at the site, we researched available well logs located within Sections 25 and 36, Township 2 South, Range 1 East on the Oregon Water Resources Department (OWRD)<sup>3</sup> website. Our review indicated that groundwater levels ranged from about 25 to 75 feet bgs in the vicinity of the site. It should be noted that groundwater levels vary with local topography. In addition, the groundwater levels reported on the OWRD logs often reflect the purpose of the well, so water well logs may only report deeper, confined groundwater, while geotechnical or environmental borings will often report any groundwater encountered, including shallow, unconfined groundwater. Therefore, the levels reported on the OWRD well logs referenced above are considered generally indicative of local water levels and may not reflect actual groundwater levels at the project site. We anticipate that groundwater levels will fluctuate due to seasonal and annual variations in precipitation, changes in site utilization, or other factors. Additionally, the on-site fill soils (CL FILL) and native lean to fat clay (CL-CH) are conducive to formation of perched groundwater.

---

<sup>3</sup> Oregon Water Resources Department, 2015. Water well logs obtained from OWRD website <http://www.wrd.state.or.us/>

## 6.0 SITE SPECIFIC SEISMIC HAZARDS STUDY

### 6.1 Overview

We performed a Site-Specific Seismic Hazards Study for the site in accordance with Section 1803 of the 2014 Oregon Structural Specialty Code (OSSC). The complete results of our hazards study are presented in the attached Appendix B. The following conclusions highlight the results of our SSSHs:

- We conclude that the soils encountered in the borings are non-liquefiable within the depths explored.
- We conclude there is a negligible risk of slope instability from a design-level earthquake.
- We conclude there is a low risk of surface rupture from faulting.
- We conclude there is a very low risk of surface rupture from lateral spread.
- We conclude there is a negligible risk of seiche inundation at this site.

### 6.2 Seismic Ground Motion Values

Earthquake ground motion parameters for the site were obtained based on the United States Geological Survey (USGS) Seismic Design Values for Buildings - Ground Motion Parameter Calculator<sup>4</sup>. The following table presents seismic ground motion values recommended for use in structural design of structures at this site.

**Table 1 Seismic Ground Motion Values (Section 1613.3.2 of 2014 OSSC)**

Parameter		Value
Mapped Acceleration Parameters	Spectral Acceleration, 0.2 second ( $S_s$ )	0.945g
	Spectral Acceleration, 1.0 second ( $S_1$ )	0.407g
Coefficients (Site Class D)	Site Coefficient, 0.2 sec. ( $F_a$ )	1.122
	Site Coefficient, 1.0 sec. ( $F_v$ )	1.593
Adjusted MCE Spectral Response Parameters	MCE Spectral Acceleration, 0.2 sec. ( $S_{MS}$ )	1.060g
	MCE Spectral Acceleration, 1.0 sec. ( $S_{M1}$ )	0.648g
Design Spectral Response Accelerations	Design Spectral Acceleration, 0.2 seconds ( $S_{DS}$ )	0.707g
	Design Spectral Acceleration, 1.0 second ( $S_{D1}$ )	0.432g

## 7.0 GEOTECHNICAL REVIEW & DISCUSSION

Based on the results of our field explorations and analyses, the site may be developed as described in Section 1.1 of this report, provided the recommendations presented in this report are incorporated into the design and development. Furthermore, based on the results of our field investigation, we do not anticipate particularly difficult excavation conditions (i.e., due to presence of hard rock and/or boulders) for shallow foundations or the proposed daylight basement within the southeast portion of the new school building.

We conclude the primary geotechnical consideration at this site to be the presence of near-surface, moisture-sensitive soils that are susceptible to disturbance during wet weather. Trafficability of these

<sup>4</sup> United States Geological Survey, 2014. Seismic Design Parameters determined using; "U.S. Seismic Design Maps Web Application," from the USGS website <http://geohazards.usgs.gov/designmaps/us/application.php>.

soils may be difficult, and significant damage to the subgrade could occur, if earthwork is undertaken without proper precautions at times when the exposed soils are more than a few percentage points above optimum moisture content. If construction for this project occurs during what is typically known as the wet season in this region, we recommend measures be implemented to protect fine-grained subgrade in areas of repeated construction traffic and in foundation bearing areas. Recommendations for wet weather construction are presented in Section 8.3 of this report. Re-use of the on-site soils as structural fill during wet times of the year will require special consideration as discussed in Section 8.4.1 of this report.

## **8.0 PRELIMINARY RECOMMENDATIONS**

The recommendations presented in this report are based on the information provided to us, results of the field investigation, laboratory data, and professional judgment. This report is considered preliminary, as we have not reviewed final grading plans, finished floor elevations, and/or detailed structural information for the development. An addendum indicating that this report is final, and including supplemental recommendations, if warranted, can be issued after we have reviewed those items.

CGT has observed only a small portion of the pertinent subsurface conditions. The recommendations are based on the assumptions that the subsurface conditions do not deviate appreciably from those found during the field investigation. CGT should be consulted for further recommendations if the design and/or location of the proposed development changes, or variations and/or undesirable geotechnical conditions are encountered during site development.

### **8.1 Site Preparation**

#### **8.1.1 Demolition**

Demolition of the existing Sunset Primary School building should include complete removal of all structural elements, including foundations and concrete slabs. Abandoned buried utilities should similarly be removed or grouted full. We understand demolition of the existing school structure will commence once the new school has been constructed. Therefore, we anticipate concrete debris resulting from demolition will be hauled off site for disposal.

Any concrete or asphaltic concrete debris resulting from any demolition *prior* to the construction of the new school may be re-used as structural fill, provided it is processed in accordance with the recommendations presented in Section 8.4.1 of this report. Alternatively, demolition debris should be hauled off site for disposal.

#### **8.1.2 Site Stripping**

Existing topsoil, pavements and underlying base rock, lean clay fill (CL FILL), rooted soils and vegetation, and landscaping fill should be removed from within, and for a minimum 5-foot margin around, the proposed building pad, structural fill, and pavement areas. Based on the results of our field explorations, the following stripping depths are anticipated:

- *New School Building Pad* – We observed organic silt topsoil (OL) depths within this area ranging from about  $\frac{1}{3}$ -to 1-foot bgs. At test pit TP-4 and boring B-2, we observed lean clay fill (CL FILL) to a depth of about 2 feet, likely placed to level out the existing baseball/play field. Stripped lean clay fill, rooted

soils, vegetation, and landscaping materials should be transported off-site for disposal, or stockpiled for later use in landscaped areas.

- *New Bus Drop-off and Parking Lot Pavements* – Since the west wing of the existing Sunset Primary School building occupies the proposed main parking lot, CGT was unable to explore the subsurface conditions in this area. Therefore, stripping depths associated with the main parking lot area will need to be assessed after/during demolition of the existing school structure. We explored the subsurface conditions of the proposed bus drop-off area and auxiliary parking lot with pavement cores C-1 and C-2. The existing pavement section and underlying base rock extended to respective depths ranging from about 9 inches to about 2 feet in C-1 and C-2. It should be noted that practical refusal in the base rock was encountered at a depth of about 22 inches bgs in core C-2. Therefore, the base rock likely extends deeper than 22 inches bgs in this area. The geotechnical engineer or his representative should provide recommendations for actual stripping depths based on observations made during site stripping. Stripped pavements and base rock should be transported off-site or stockpiled for processing for use as structural fill as described in Section 8.4.1 of this report.

#### 8.1.3 Grubbing

Grubbing of trees and shrubs should include the removal of the root mass, and roots greater than 1 inch in diameter. Grubbed materials should be transported off-site for disposal. Where root masses are removed, the resulting excavation should be properly backfilled with imported granular structural fill in conformance with Section 8.4.2 of this report, as needed to achieve design subgrade elevations.

#### 8.1.4 Existing Utilities & Below-Grade Structures

All existing utilities at the site should be identified prior to excavation. Abandoned utility lines beneath the new building, pavements, and hardscaping features should be completely removed or grouted full. Soft, loose, or otherwise unsuitable soils encountered in utility trench excavations should be removed and replaced with structural fill as described in Section 8.4 of this report. Buried structures (i.e. footings, foundation walls, retaining walls, slabs-on-grade, tanks, etc.), if encountered during site development, should be completely removed and replaced with structural fill in conformance with Section 8.4 of this report.

#### 8.1.5 Subgrade Preparation – Building Pad & Pavement Areas

##### 8.1.5.1 Dry Weather Construction

After site preparation as recommended above, but prior to placement of structural fill and/or aggregate base, the geotechnical engineer or his representative should observe a proof roll test of the exposed subgrade soils in order to identify areas of excessive yielding. Proof rolling of subgrade soils is typically conducted during dry weather conditions using a fully-loaded, 10- to 12-cubic-yard, tandem-axle, tire-mounted, dump truck or equivalent weighted water truck. Areas that appear too soft and wet to support proof rolling equipment should be prepared in general accordance with the recommendations for wet weather construction presented in Section 8.3 of this report. If areas of soft soil or excessive yielding are identified, the affected material should be over-excavated to firm, stable subgrade, and replaced with imported granular structural fill in conformance with Section 8.4.2 of this report.

##### 8.1.5.2 Wet Weather Construction

Preparation of building pad and pavement subgrade soils during wet weather should be in conformance with Section 8.3 of this report. As indicated therein, increased base rock sections and a geotextile

separation fabric may be required in wet conditions in order to support construction traffic and protect the subgrade. Cement amendment may also be considered to help stabilize subgrade soils during wet weather.

#### 8.1.6 Erosion Control

Erosion and sedimentation control measures should be employed in accordance with applicable City, County, and State regulations regarding erosion control.

### **8.2 Temporary Excavations**

#### 8.2.1 Overview

Conventional earthmoving equipment in proper working condition should be capable of making necessary excavations for the anticipated site cuts as described earlier in this report. All excavations should be in accordance with applicable OSHA and state regulations. It is the contractor's responsibility to select the excavation methods, to monitor site excavations for safety, and to provide any shoring required to protect personnel and adjacent improvements. A "competent person", as defined by OR-OSHA, should be on-site during construction in accordance with regulations presented by OR-OSHA. CGT's current role on the project does not include review or oversight of excavation safety.

#### 8.2.2 OSHA Soil Type

For use in the planning and construction of temporary excavations up to 8 feet in depth, an OSHA soil type "B" may be used for the on-site, native, lean clay to fat clay (CL-CH).

#### 8.2.3 Dewatering

Based on the results of the explorations, we do not anticipate that site excavations extending to depths less than 10 feet will require area-wide dewatering during construction. Temporary dewatering of utility trenches and other localized excavations may be required in the event perched groundwater is encountered or during extended periods of inclement weather. We anticipate pumping from sumps should be effective in removing perched groundwater at the site. Disposal locations should be reviewed by the project civil engineer. If groundwater seepage is encountered on temporary cut slopes during construction, provisions may be required to collect and divert the water from the cut slope and reduce the potential of instability. The geotechnical engineer should be consulted in the event groundwater seepage emerges within temporary cut slopes.

#### 8.2.4 Utility Trenches

Temporary trench cuts should stand near vertical to depths of approximately 4 feet in the on-site native lean clay to fat clay (CL-CH) and sandy lean clay with gravel (CL) encountered at the site. Some instability may occur in this soil if groundwater seepage is encountered. If seepage undermines the stability of the trench, or if caving of the sidewalls is observed during excavation, the sidewalls should be flattened or shored. Depending on the time of year trench excavations occur, trench dewatering may be required in order to maintain dry working conditions, particularly if the invert elevations of the proposed utilities are below the groundwater level. If groundwater is present at the base of utility excavations, we recommend placing trench stabilization material at the base of the excavations. Trench stabilization material should be in conformance with Section 8.4.4 of this report.

### 8.2.5 Excavations near Foundations

Excavations near footings should not extend within a 1H:1V (horizontal to vertical) plane projected out and down from the outside, bottom edge of the footings. In the event that excavation needs to extend within the referenced plane, temporary shoring of the excavation and/or underpinning of the subject footing may be required. The geotechnical engineer should be consulted to review proposed excavation plans for this design case to provide specific recommendations.

## 8.3 **Wet Weather Considerations**

For planning purposes, the wet season should be considered to extend from late September to late June. It is our experience that dry weather working conditions should prevail between early July and the middle of September. Notwithstanding the above, soil conditions should be evaluated in the field by the geotechnical engineer or his representative at the initial stage of site preparation to determine whether the recommendations within this section should be incorporated into construction.

### 8.3.1 General

The near-surface clay soils are susceptible to disturbance during wet weather. Trafficability of these soils may be difficult, and significant damage to subgrade soils could occur, if earthwork is undertaken without proper precautions at times when the exposed soils are more than a few percentage points above optimum moisture content. For construction that occurs during wet weather, site preparation activities may need to be accomplished using track-mounted equipment, loading removed material onto trucks supported on granular haul roads, or other methods to limit soil disturbance. The geotechnical engineer or his representative should evaluate the subgrade during excavation by probing rather than proof rolling. Soils that have been disturbed during site preparation activities, or soft or loose areas identified during probing, should be over-excavated to firm, stable subgrade, and replaced with imported granular structural fill.

### 8.3.2 Geotextile Separation Fabric

We recommend a geotextile separation fabric be placed to serve as a barrier between the prepared fine-grained subgrade and granular fill/base rock in areas of repeated or heavy construction traffic. The geotextile fabric should be in conformance with Section 02320 of the current Oregon Department of Transportation (ODOT) Standard Specification for Construction.

### 8.3.3 Granular Working Surfaces (Haul Roads & Staging Areas)

Haul roads subjected to repeated heavy, tire-mounted, construction traffic (e.g. dump trucks, concrete trucks, etc.) will require a minimum of 18 inches of imported granular material. For light staging areas, 12 inches of imported granular material is typically sufficient. Additional granular material, geo-grid reinforcement, or cement amendment may be recommended based on site conditions and/or loading at the time of construction. The imported granular material should be in conformance with Section 8.4.2 of this report and have less than 5 percent material passing the U.S. Standard No. 200 Sieve. The prepared subgrade should be covered with geotextile fabric prior to placement of the imported granular material. The imported granular material should be placed in a single lift (up to 24 inches thick) and compacted using a smooth-drum, non-vibratory roller until well-keyed.

#### 8.3.4 Footing Subgrade Protection

A minimum of 3 inches of imported granular material is recommended to protect fine-grained footing subgrades from foot traffic during inclement weather. The imported granular material should be in conformance with Section 8.4.2 of this report, have less than 5 percent material passing the U.S. Standard No. 200 Sieve, and have a maximum particle size limited to 1 inch. The imported granular material should be placed in one lift over the prepared, undisturbed subgrade, and compacted using non-vibratory equipment until well keyed.

#### 8.3.5 Cement Amendment

It is sometimes less costly to amend near-surface, moisture-sensitive, fine-grained soils with Portland cement than to remove and replace those soils with imported granular material. Successful use of soil cement amendment depends on the use of correct techniques and equipment, soil moisture content, and the amount of cement added to the subgrade (mix design). We anticipate the on-site clay soils (CL-CH) are conducive to cement amendment due to their low plasticity and our experience with similar soils.

The recommended percentage of cement is based on soil moisture contents at the time the work is performed. Based on our experience, 3 percent cement by weight of dry soil can generally be used when the soil moisture content does not exceed approximately 20 percent. If the soil moisture content is in the range of 25 to 35 percent, 4 to 6 percent by weight of dry soil is recommended. It is difficult to accurately predict field performance due to the variability in soil response to cement amendment. The amount of cement added to the soil may need to be adjusted based on field observations and performance.

If cement amendment is considered, we recommend additional sampling, laboratory testing, and a mix design be performed to determine the level of improvement in engineering properties (strength, stiffness) of the on-site soils when blended with Portland cement. We recommend project scheduling allow for a minimum of 3 weeks for this testing and design to be completed, prior to initiating cement amendment.

### 8.4 **Structural Fill**

The geotechnical engineer should be provided the opportunity to review all materials considered for use as structural fill (prior to placement). The geotechnical engineer or his representative should be contacted to evaluate compaction of structural fill as the material is being placed. Evaluation of compaction may take the form of in-place density tests and/or proof roll tests with suitable equipment. Structural fill should be evaluated at intervals not exceeding every 2 vertical feet as the fill is being placed.

#### 8.4.1 On-Site Soils – General Use

##### 8.4.1.1 Asphalt & Concrete Debris

Asphalt and concrete debris resulting from the demolition of existing pavements and other features (foundations, floor slabs, sidewalks, etc.) can be re-used as structural fill if processed/crushed into material that is fairly well graded between coarse and fine. The processed/crushed concrete and/or asphalt should contain no organic matter, debris, or particles larger than 4 inches in diameter. Moisture conditioning (wetting) should be expected in order to achieve adequate compaction. When used as structural fill, this material should be placed and compacted in general accordance with Section 8.4.2 of this report.



#### 8.4.1.2 Undocumented Gravel Fill (GP Fill)

Re-use of the gravel fill materials (underlying the existing pavements) as structural fill is feasible, provided they can be kept free of debris, deleterious materials, and particles larger than 4 inches in diameter. If used as structural fill, these materials should be prepared in conformance with Section 8.4.2 of this report.

#### 8.4.1.3 Residual Soils (CL-CH) and Decomposed Volcaniclastics (CL and SC)

Re-use of these soils as structural fill may be difficult because these soils are sensitive to small changes in moisture content and are difficult, if not impossible, to adequately compact during wet weather. We anticipate the moisture content of these soils will be higher than the optimum moisture content for satisfactory compaction. Therefore, moisture conditioning (drying) should be expected in order to achieve adequate compaction. If used as structural fill, these soils should be free of organic matter, debris, and particles larger than 4 inches. When used as structural fill, these soils should be placed in lifts with a maximum thickness of about 8 inches at moisture contents within -1 and +3 percent of optimum, and compacted to not less than 92 percent of the material's maximum dry density, as determined in general accordance with ASTM D1557 (Modified Proctor).

If the on-site soils cannot be properly moisture-conditioned and/or processed, we recommend using imported granular material for structural fill.

#### 8.4.2 Imported Granular Structural Fill – General Use

Imported granular structural fill should consist of angular pit or quarry run rock, crushed rock, or crushed gravel that is fairly well graded between coarse and fine particle sizes. The granular fill should contain no organic matter, debris, or particles larger than 4 inches, and have less than 5 percent material passing the U.S. Standard No. 200 Sieve. For fine-grading purposes, the maximum particle size should be limited to 1½ inches. The percentage of fines can be increased to 12 percent of the material passing the U.S. Standard No. 200 Sieve if placed during dry weather, and provided the fill material is moisture-conditioned, as necessary, for proper compaction. Granular fill material should be placed in lifts with a maximum thickness of about 12 inches, and compacted to not less than 95 percent of the material's maximum dry density, as determined in general accordance with ASTM D1557 (Modified Proctor). Proper moisture conditioning and the use of vibratory equipment will facilitate compaction of these materials.

Compaction of granular fill materials with high percentages of particle sizes in excess of 1½-inches should be evaluated by periodic proof-roll observation or continuous observation by the geotechnical engineering representative during fill placement, since it cannot be tested conventionally using a nuclear densometer. Such materials should be "capped" with a minimum of 12 inches of ¾-inch-minus (or finer) granular fill under all structural elements (footings, concrete slabs, etc.).

#### 8.4.3 Floor Slab Base Rock

Floor slab base rock should consist of well-graded granular material (crushed rock) containing no organic matter or debris, have a maximum particle size of ¾ inch, and have less than 5 percent material passing the U.S. Standard No. 200 Sieve. Floor slab base rock should be placed in one lift and compacted to not less than 95 percent of the material's maximum dry density as determined in general accordance with ASTM D1557 (Modified Proctor).

#### 8.4.4 Trench Base Stabilization Material

If groundwater is present at the base of utility excavations, trench base stabilization material should be placed. Trench base stabilization material should consist of a minimum of 1 foot of well-graded granular material with a maximum particle size of 4 inches and less than 5 percent material passing the U.S. Standard No. 4 Sieve. The material should be free of organic matter and other deleterious material, placed in one lift, and compacted until well-keyed.

#### 8.4.5 Trench Backfill Material

Trench backfill for the utility pipe base and pipe zone should consist of granular material as recommended by the utility pipe manufacturer. Trench backfill above the pipe zone should consist of well-graded granular material containing no organic matter or debris, have a maximum particle size of ¾ inch, and have less than 8 percent material passing the U.S. Standard No. 200 Sieve. As a guideline, trench backfill should be placed in maximum 12-inch-thick lifts. The earthwork contractor may elect to use alternative lift thicknesses based on their experience with specific equipment and fill material conditions during construction in order to achieve the required compaction. The following table presents recommended relative compaction percentages for utility trench backfill.

**Table 2 Utility Trench Backfill Compaction Recommendations**

Backfill Zone	Recommended Minimum Relative Compaction	
	Structural Areas <sup>1</sup>	Landscaping Areas
Pipe Base and Within Pipe Zone	90% ASTM D1557 or pipe manufacturer's recommendation	88% ASTM D1557 or pipe manufacturer's recommendation
Above Pipe Zone	92% ASTM D1557	90% ASTM D1557
Within 3 Feet of Design Subgrade	95% ASTM D1557	90% ASTM D1557

<sup>1</sup>Includes proposed building, pavements, structural fill areas, exterior hardscaping, etc.

#### 8.4.6 Controlled Low-Strength Material (CLSM)

CLSM is a self-compacting, cementitious material that is typically considered when backfilling localized areas. CLSM is sometimes referred to as "controlled density fill" or CDF. Due to its flowable characteristics, CLSM typically can be placed in restricted-access excavations where placing and compacting fill is difficult. If chosen for use at this site, we recommend the CLSM be in conformance with Section 00442 of the most recent, State of Oregon, Standard Specifications for Highway Construction. The geotechnical engineer's representative should observe placement of the CLSM and obtain samples for compression testing in accordance with ASTM D4832. As a guideline, for each day's placement, two compressive strength specimens from the same CLSM sample should be tested. The results of the two individual compressive strength tests should be averaged to obtain the reported 28-day compressive strength.

### 8.5 Permanent Slopes

Permanent cut or fill slopes constructed at the site should be graded at 2H:1V or flatter. Constructed slopes should be overbuilt by a few feet depending on their size and gradient so that they can be properly compacted prior to being cut to final grade. The surface of all slopes should be protected from erosion by

seeding, sodding, or other acceptable means. Adjacent on-site and off-site structures should be located at least 5 feet from the top of slopes.

New fill should be placed and compacted against horizontal surfaces. Where slopes exceed 5H:1V (horizontal:vertical), the slopes should be keyed and benched prior to structural fill placement in general accordance with the attached Fill Slope Detail, Figure 21. If subdrains are needed on benches, subject to the review of the CGT geotechnical representative, they should be placed as shown on the attached Fill Slope Detail. In order to achieve well compacted slope faces, slopes should be overbuilt by a few feet and then trimmed back to proposed final grades. A representative from CGT should observe the benches, keyways, and associated subdrains, if needed, prior to placement of structural fill.

## **8.6 Shallow Foundations**

### **8.6.1 Subgrade Preparation**

Satisfactory subgrade support for shallow foundations associated with the planned building addition can be obtained from the native, residual soils (CL-CH), volcanoclastics (CL and SC) or on structural fill that is properly placed and compacted on these materials during construction. The geotechnical engineer or his representative should be contacted to observe subgrade conditions prior to placement of forms, reinforcement steel, or structural fill (if required). If undocumented fill, organic, soft, loose, or otherwise unsuitable soils are encountered, they should be over-excavated as recommended by the geotechnical representative at the time of construction. The resulting over-excavation should be brought back to grade with imported granular structural fill in conformance with Section 8.4.2 of this report. The maximum particle size of over-excavation backfill should be limited to 1½ inches. All granular pads for footings should be constructed a minimum of 6 inches wider on each side of the footing for every vertical foot of over-excavation.

### **8.6.2 Minimum Footing Width & Embedment**

Minimum footing widths should be in conformance with the most recent, Oregon Structural Specialty Code (OSSC). As a guideline, we recommend individual spread footings have a minimum width of 24 inches. Subject to review of the project structural engineer, we recommend continuous wall footings have a minimum width of 18 inches. All footings should be founded at least 18 inches below the lowest, permanent adjacent grade.

### **8.6.3 Bearing Pressure & Settlement**

Footings founded as recommended above should be proportioned for a maximum allowable soil bearing pressure of 2,500 pounds per square foot (psf). This bearing pressure is a net bearing pressure, applies to the total of dead and long-term live loads, and may be increased by one-third when considering seismic or wind loads. For foundations founded as recommended above, total settlement of foundations is anticipated to be less than 1 inch. Differential settlements between adjacent columns and/or bearing walls should not exceed ½-inch.

### **8.6.4 Lateral Capacity**

A maximum passive (equivalent fluid) earth pressure of 150 pounds per cubic foot (pcf) is recommended for design of footings confined by the native soils described above, or imported granular structural fill that is properly placed and compacted during construction. The recommended earth pressure was computed

using a factor of safety of 1½, which is appropriate due to the amount of movement required to develop full passive resistance. In order to develop the above capacity, the following should be understood:

1. Concrete must be poured neat in excavations or the foundations must be backfilled with imported granular structural fill,
2. The adjacent grade must be level,
3. The static ground water level must remain below the base of the footings throughout the year.
4. Adjacent floor slabs, pavements, or the upper 12-inch-depth of adjacent, unpaved areas should not be considered when calculating passive resistance.

An ultimate coefficient of friction equal to 0.35 may be used when calculating resistance to sliding for footings founded on the native soils described above. An ultimate coefficient of friction equal to 0.45 may be used when calculating resistance to sliding for footings founded on a minimum of 6 inches of imported granular structural fill (crushed rock) that is properly placed and compacted during construction.

#### 8.6.5 Subsurface Drainage

Recognizing the fine-grained nature of the site soils, placement of perimeter foundation drains is recommended at the base elevations of continuous wall footings on the outside of footings. Foundation drains should consist of a minimum 4-inch-diameter, perforated, HDPE (High Density Polyethylene) drainpipe wrapped with a non-woven geotextile filter fabric. The drains should be backfilled with a minimum of 2 cubic feet of open graded drain rock per lineal foot of pipe. The drain rock should be encased in a geotextile filter fabric in order to provide separation from the surrounding soils. Foundation drains should be positively sloped and should outlet to a suitable discharge point. A representative from CGT should be contacted to observe the drains prior to backfilling. Roof drains should not be tied into foundation drains.

### 8.7 **Rigid Retaining Walls**

#### 8.7.1 Footings

Retaining wall footings should be designed and constructed in conformance with the recommendations presented in Section 8.6 of this report, as applicable.

#### 8.7.2 Wall Drains

We recommend retaining wall drains consist of a minimum 4-inch diameter, perforated, HDPE (High Density Poly-Ethylene) drainpipe wrapped with a non-woven geotextile filter fabric. The drains should be backfilled with a minimum of 2 cubic feet of open graded drain rock per lineal foot of pipe. The drain rock should be encased in a geotextile fabric in order to provide separation from the surrounding soils. Retaining wall drains should be positively sloped and should outlet to a suitable discharge point. The geotechnical engineer or his representative should be contacted to observe the drains prior to backfilling.

#### 8.7.3 Backfill

Retaining walls should be backfilled with imported granular structural fill in conformance with Section 8.4.2 of this report and contain less than 5 percent passing the U.S. Standard No. 200 Sieve. The backfill should be compacted to a minimum of 90 percent of the material's maximum dry density as determined in general accordance with ASTM D1557 (Modified Proctor). When placing fill behind walls,

care must be taken to minimize undue lateral loads on the walls. Heavy compaction equipment should be kept at least “H” feet from the back of the walls, where “H” is the height of the wall. Light mechanical or hand tamping equipment should be used for compaction of backfill materials within “H” feet of the back of the walls.

#### 8.7.4 Design Considerations

For rigid retaining walls founded, backfilled, and drained as recommended above, the following table presents parameters recommended for design.

**Table 3 Design Parameters for Rigid Retaining Walls**

Retaining Wall Condition	Modeled Backfill Condition	Static Equivalent Fluid Pressure (S <sub>A</sub> )	Additional Seismic Equivalent Fluid Pressure (S <sub>AE</sub> )	Surcharge from Uniform Load, q, Acting on Backfill Behind Retaining Wall
Not Restrained from Rotation	Level (i = 0)	29 pcf	12 pcf	0.22*q
Restrained from Rotation	Level (i = 0)	52 pcf	5 pcf	0.38*q

Note 1. Refer to the attached Figure 22 for a graphical representation of static and seismic loading conditions. Seismic component of active thrust acts at 0.6H above the base of the wall.

Note 2. Seismic (dynamic) lateral loads were computed using the Mononobe-Okabe Equation as presented in the 1997 Federal Highway Administration (FHWA) design manual.

The above design recommendations are based on the assumptions that:

- (1) the walls consist of concrete cantilevered retaining walls ( $\beta = 0$  and  $\delta = 24$  degrees, see Figure 22).
- (2) the walls are 10 feet or less in height.
- (3) the backfill is drained and consists of imported granular structural fill ( $\phi = 38$  degrees).
- (4) no line load, point, or area load surcharges are imposed behind the walls.
- (5) the grade behind the wall is level, or sloping down and away from the wall, for a distance of 10 feet or more from the wall.
- (6) the grade in front of the walls is level or sloping up for a distance of at least 5 feet from the wall.

Re-evaluation of our recommendations will be required if the retaining wall design criteria for the project vary from these assumptions.

### 8.8 Floor Slabs

#### 8.8.1 Subgrade Preparation

Floor slab subgrade preparation should be in conformance with Section 8.1.5 of this report.

#### 8.8.2 Crushed Rock Base

Concrete floor slabs should be supported on a minimum 6-inch-thick layer of crushed rock (base rock) in conformance with Section 8.4.3 of this report. We recommend “choking” the surface of the base rock with fine sand just prior to concrete placement. Choking means the voids between the largest aggregate particles are filled with sand, but does not provide a layer of sand above the base rock. Choking the base rock surface reduces the lateral restraint on the bottom of the concrete during curing. Fine sand used for

choking purposes should be in conformance with Section 00360.10 of the most recent State of Oregon, Standard Specifications for Highway Construction (OSSC).

### 8.8.3 Design Considerations

For floor slabs constructed as recommended, a modulus of subgrade reaction of 75 pounds per cubic inch (pci) is recommended for the design of the floor slab. Floor slabs constructed as recommended will likely settle less than ½-inch. For general floor slab construction, slabs should be jointed around columns and walls to permit slabs and foundations to settle differentially.

### 8.8.4 Subgrade Moisture Considerations

Liquid moisture and moisture vapor should be expected at the subgrade surface. The recommended crushed rock base is anticipated to provide protection against liquid moisture. Where moisture vapor emission through the slab must be minimized, e.g. impervious floor coverings, storage of moisture sensitive materials directly on the slab surface, etc., a vapor retarding membrane or vapor barrier below the slab should be considered. Factors such as cost, special considerations for construction, floor coverings, and end use suggest that the decision regarding a vapor retarding membrane or vapor barrier be made by the architect and owner.

If a vapor retarder or vapor barrier is placed below the slab, its location should be based on current American Concrete Institute (ACI) guidelines, ACI 302 Guide for Concrete Floor and Slab Construction. In some cases, this indicates placement of concrete directly on the vapor retarder or barrier. Please note that the placement of concrete directly on impervious membranes increases the risk of plastic shrinkage cracking and slab curling in the concrete. Construction practices to reduce or eliminate such risk, as described in ACI 302, should be employed during concrete placement.

## **8.9 Flexible Pavements**

### 8.9.1 Subgrade Preparation

Pavement subgrade preparation should be in conformance with Section 8.1.5 of this report. Pavement subgrade surfaces should be crowned (or sloped) for proper drainage in accordance with specifications provided by the project civil engineer.

### 8.9.2 Input Parameters

Design of the hot mixed asphaltic concrete (HMAC) pavement sections presented below was based on the parameters presented in the following table and the American Association of State Highway and Transportation Officials (AASHTO) 1993 "Design of Pavement Structures" manual. If any of the items listed need revised, please contact us and we will reassess the provided design sections.

**Table 4 Input Parameters Used in HMAC Pavement Design**

Input Parameter	Design Value <sup>1</sup>	Input Parameter	Design Value <sup>1</sup>
Pavement Design Life	20 years	Resilient Modulus	Subgrade (Native Clay) <sup>3</sup>
Annual Percent Growth	0 percent		Crushed Aggregate Base
Serviceability	4.2 initial, 2.5 terminal	Structural Coefficient	Crushed Aggregate Base
Reliability	75 percent		Asphalt
Standard Deviation	0.49	Vehicle Traffic <sup>4</sup> (ESALs)	APAO Level I (Very Light)
Drainage Factor <sup>2</sup>	1.0		APAO Level II (Light)

<sup>1</sup> If any of the above parameters are incorrect, please contact us so that we may revise our recommendations, if warranted.  
<sup>2</sup> Assumes good drainage away from pavement, base, and subgrade is achieved by proper crowning of subgrades.  
<sup>3</sup> Values based on experience with similar soils in the region.  
<sup>4</sup> ESAL = Total 18-Kip equivalent single axle load. Traffic levels taken from Table 3.1 of APAO manual. If actual traffic levels will be above those identified above, the geotechnical engineer should be consulted.

**8.9.3 Recommended Minimum Sections**

The following table presents the minimum HMAC pavement sections for the design traffic levels indicated in Table 4 above, based on the referenced AASHTO procedures.

**Table 5 Recommended Minimum HMAC Pavement Sections**

Material	Material Thickness (inches)	
	APAO Level I (Passenger Car Parking)	APAO Level II (Bus/Entrance/Service Drive Lanes)
HMAC Pavement	3	4
Aggregate Base <sup>1</sup>	7	9
Subgrade Soils	Prepared in conformance with Section 8.1.5 of this report.	

<sup>1</sup> Thickness shown assumes dry weather construction. Increased base rock sections and/or a geotextile separation fabric may be required in wet conditions in order to support construction traffic and protect the subgrade. Refer to Section 8.3 for additional discussion.

**8.9.4 HMAC Pavement Materials**

We recommend pavement aggregate base consist of dense-graded aggregate in conformance with Section 02630.10 of the most recent State of Oregon, Standard Specifications for Highway Construction (OSSC), with the following additional considerations. We recommend the material consist of crushed rock or gravel, have a maximum particle size of 1½ inches, and have less than 5 percent material passing the U.S. Standard No. 200 Sieve. Aggregate base should be compacted to not less than 95 percent of the material's maximum dry density as determined in general accordance with ASTM D1557 (Modified Proctor).

We recommend asphalt pavement consist of Level 2, ½-inch, dense-graded HMAC in conformance with the most recent OSSC. Asphalt pavement should be compacted to at least 91 percent of the material's theoretical maximum density as determined in general accordance with ASTM D2041 (Rice Specific Gravity).

## 8.10 Rigid (Concrete) Pavements

### 8.10.1 Subgrade Preparation

Subgrade preparation of pavements should be in conformance with Section 8.1.5 of this report. Pavement subgrade surfaces should be crowned (or sloped) for proper drainage in accordance with specifications provided by the project civil engineer.

### 8.10.2 Input Parameters

Design of the rigid pavement sections presented below was based on the assumed parameters presented in the following table and the AASHTO design manual referenced in Section 8.9.2. If any of the items listed need revision, please contact us and we will reassess the pavement design section provided in Table 7. Jointing, reinforcement, and surface finish should be performed in accordance with the project civil engineer, architect, and owner requirements.

**Table 6 Input Parameters Used in Concrete Pavement Design**

Parameter / Discussion		Design Value
Load Transfer Devices incorporated?		Yes; Load Transfer Coefficient <sup>2</sup> = 3.2
<u>Minimum</u> Concrete Modulus of Rupture		600 psi
Mean Concrete Elastic Modulus		5.0 x 10 <sup>6</sup> psi
Minimum Air-Entrained Concrete Comp. Strength		4,000 psi
Inherent Reliability		75 Percent
Granular All-Weather Leveling Course		Yes
Vehicle Traffic <sup>1</sup> (range)	APAO Level I (Very Light)	10,000 ESAL
	APAO Level II (Light)	50,000 ESAL
<sup>1</sup> ESAL = Total 18-Kip equivalent single axle load. Traffic levels taken from Table 3.1 of APAO manual.		
<sup>2</sup> Recommended default value per AASHTO.		

### 8.10.3 Recommended Minimum Sections

The following table presents the recommended minimum concrete pavement sections based on the referenced AASHTO procedures.

**Table 7 Recommended Minimum Concrete Pavement Section**

Material	APAO Traffic Loading	
	Level I	Level II
Portland Cement Concrete, PCC <sup>1</sup> (inches)	3½	4½
Leveling Coarse, Sand or All-Weather Base <sup>2,3</sup> (inches)	4	4
Subgrade Soils	Prepared in conformance with Section 8.10.1	
<sup>1</sup> Concrete strength and other properties should be in conformance with Table 9.		
<sup>2</sup> Leveling coarse thickness should be a <u>minimum</u> of four times the maximum particle size. Example. If crushed rock up to ¾ inch in diameter is used, the leveling course should be at least 3 inches thick.		
<sup>3</sup> Increased base rock sections and/or a geotextile separation fabric may be required in wet conditions in order to support construction traffic and protect the subgrade. Refer to Section 8.3 for recommendations for wet weather construction.		



## **8.11 Additional Considerations**

### **8.11.1 Drainage**

Subsurface drains should be connected to the nearest storm drain, on-site stormwater infiltration system (designed by others), or other suitable discharge point. Paved surfaces and grading near or adjacent to the building should be sloped to drain away from the building. Surface water from paved surfaces and open spaces should be collected and routed to a suitable discharge point. Surface water should not be directed into foundation drains.

### **8.11.2 Expansive Potential**

The near surface native soils (residual soils) consist of moderate to high plasticity clay (CL-CH). However, based on experience with similar soils in the area of the site, these soils are not considered to be susceptible to appreciable movements from changes in moisture content. Accordingly, no special considerations are required to mitigate expansive potential of the near surface soils at the site.

## **9.0 RECOMMENDED ADDITIONAL SERVICES**

### **9.1 Design Review**

Geotechnical design review is of paramount importance. We recommend the geotechnical design review take place prior to releasing bid packets to contractors. As indicated previously, we recommend the geotechnical engineer be consulted to provide specific geotechnical recommendations and supplemental recommendations for design and construction for the selected foundation system.

### **9.2 Observation of Construction**

Satisfactory earthwork, foundation, floor slab, and pavement performance depends to a large degree on the quality of construction. Sufficient observation of the contractor's activities is a key part of determining that the work is completed in accordance with the construction drawings and specifications. Subsurface conditions observed during construction should be compared with those encountered during subsurface explorations, and recognition of changed conditions often requires experience. We recommend that qualified personnel visit the site with sufficient frequency to detect whether subsurface conditions change significantly from those observed to date and anticipated in this report. We recommend the geotechnical engineer or their representative attend a pre-construction meeting coordinated by the contractor and/or developer. The project geotechnical engineer or their representative should provide observations and/or testing of at least the following earthwork elements during construction:

- Site Stripping & Grubbing
- Subgrade Preparation for Structural Fills, Shallow Foundations, Retaining Walls, Floor Slabs & Pavements
- Compaction of Structural Fill, Retaining Wall Backfill, & Utility Trench Backfill
- Placement of Foundation Drains, Retaining Wall Drains, & Other Drains
- Compaction of Base Rock for Floor Slabs & Pavements
- Compaction of HMAc for Pavements

It is imperative that the owner and/or contractor request earthwork observations and testing at a frequency sufficient to allow the geotechnical engineer to provide a final letter of compliance for the earthwork activities.

## **10.0 LIMITATIONS**

We have prepared this report for use by the owner/developer and other members of the design and construction team for the proposed development. The opinions and recommendations contained within this report are not intended to be, nor should they be construed as a warranty of subsurface conditions, but are forwarded to assist in the planning and design process.

We have made observations based on our explorations that indicate the soil conditions at only those specific locations and only to the depths penetrated. These observations do not necessarily reflect soil types, strata thickness, or water level variations that may exist between or away from our explorations. If subsurface conditions vary from those encountered in our site explorations, CGT should be alerted to the change in conditions so that we may provide additional geotechnical recommendations, if necessary. Observation by experienced geotechnical personnel should be considered an integral part of the construction process.

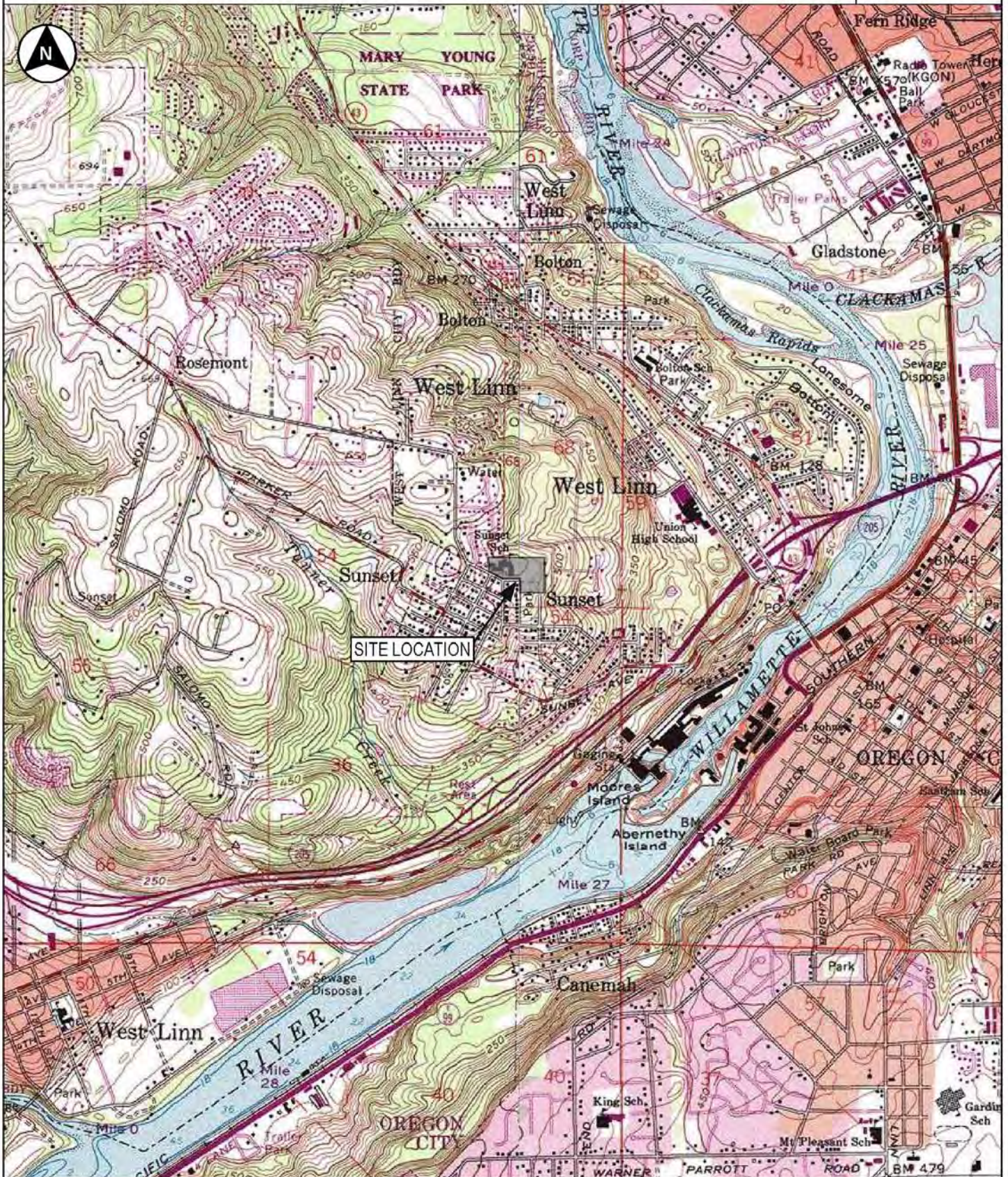
The owner/developer is responsible for ensuring that the project designers and contractors implement our recommendations. When the design has been finalized, prior to releasing bid packets to contractors, we recommend that the design drawings and specifications be reviewed by our firm to see that our recommendations have been interpreted and implemented as intended. If design changes are made, we request that we be retained to review our conclusions and recommendations and to provide a written modification or verification. Design review and construction phase testing and observation services are beyond the scope of our current assignment, but will be provided for an additional fee.

The scope of our services does not include services related to construction safety precautions, and our recommendations are not intended to direct the contractor's methods, techniques, sequences, or procedures, except as specifically described in our report for consideration in design.

Geotechnical engineering and the geologic sciences are characterized by a degree of uncertainty. Professional judgments presented in this report are based on our understanding of the proposed construction, familiarity with similar projects in the area, and on general experience. Within the limitations of scope, schedule, and budget, our services have been executed in accordance with the generally accepted practices in this area at the time this report was prepared; no warranty, expressed or implied, is made. This report is subject to review and should not be relied upon after a period of three years.

**SUNSET PRIMARY SCHOOL - WEST LINN, OREGON**  
**Project Number G1504201**

**FIGURE 1**  
**Site Location**

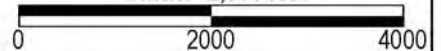


Map created with TOPO!™, © 2006 National Geographic Holdings  
 USGS 7.5 Minute Topographic Map Series, Oregon City, OR Quadrangle.

Township 2 South, Range 1 East, Section 25 Willamette Meridian

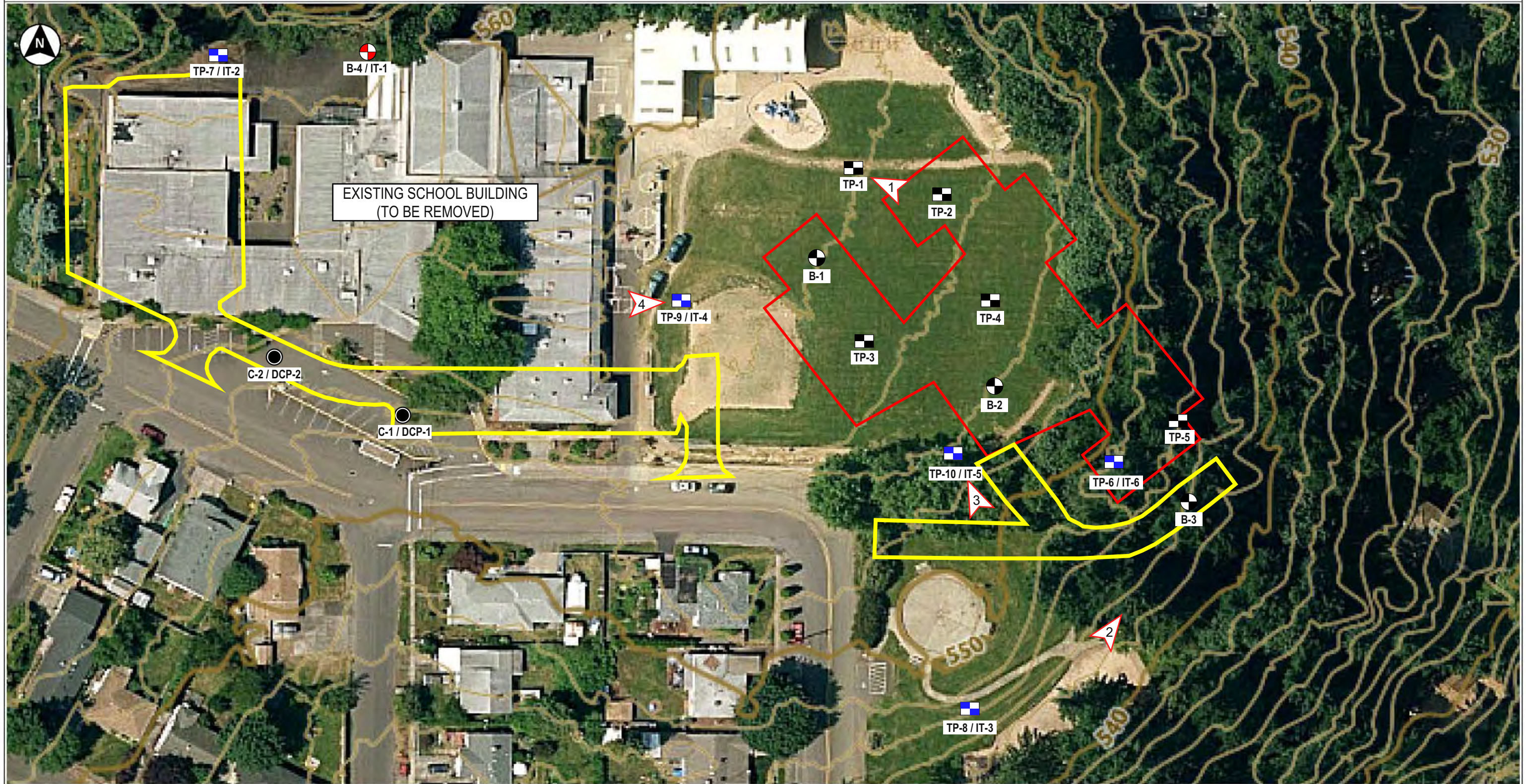
Latitude: 45.361488° North  
 Longitude: 122.626650° West





1 Inch = 2,000 feet







SUNSET PRIMARY SCHOOL - WEST LINN, OREGON  
Project Number G1504201

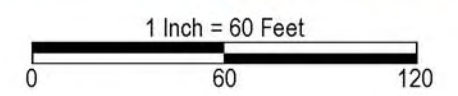
FIGURE 2  
Site Plan



- TP-1  Test pit location
- B-1  Drilled boring location
- C-1 / WDCP-1  Pavement core / Dynamic Cone Penetrometer test / hand auger boring
- B-4 / IT-1  Drilled boring / infiltration test location

LEGEND

-  1 Orientation of site photographs shown on Figure 2
- TP-7 / IT-2  Test pit / infiltration test location.
-  Approximate areas of new pavements.
-  Approximate footprint of the new Sunset Primary School.



NOTES: Map base image provided by Oregon Metro's Metromap website (<https://gis.oregonmetro.gov/metromap/>).  
Exploration locations should be considered approximate.



Photograph 1: Excavation of test pit TP-1 in progress.



Photograph 2: Drill rig at boring B-3.



Photograph 3: Looking northwest at the baseball/play field with the covered play structure in the background.



Photograph 4: Concrete debris encountered in test pit TP-9.



See Figure 2 for approximate photograph locations and directions. Photographs were taken at the time of our fieldwork.

**SUNSET PRIMARY SCHOOL - WEST LINN, OREGON**  
**Project Number G1504201**

**FIGURE 4**  
**USCS**

Classification of Terms and Content	USCS Grain Size		
NAME: MINOR Constituents (12-50%); MAJOR Constituents (>50%); Slightly (5-12%) Relative Density or Consistency Color Moisture Content Plasticity Trace Constituents (0-5%) Other: Grain Shape, Approximate Gradation, Organics, Cement, Structure, Odor... Geologic Name or Formation: Fill, Willamette Silt, Till, Alluvium, etc.	Fines	<#200 (.075 mm)	
	Sand	Fine	#200 - #40 (.425 mm)
		Medium	#40 - #10 (2 mm)
		Coarse	#10 - #4 (4.75)
	Gravel	Fine	#4 - 0.75 inch
		Coarse	0.75 inch - 3 inches
Cobbles	3 to 12 inches; scattered <15% est. numerous >15% est.		
Boulders	> 12 inches		

Relative Density or Consistency						
Granular Material		Fine-Grained (cohesive) Materials				
SPT N-Value	Density	SPT N-Value	Torvane tsf Shear Strength	Pocket Pen tsf Unconfined	Consistency	Manual Penetration Test
		<2	<0.13	<0.25	Very Soft	Thumb penetrates more than 1 inch
0 - 4	Very Loose	2 - 4	0.13 - 0.25	0.25 - 0.50	Soft	Thumb penetrates about 1 inch
4 - 10	Loose	4 - 8	0.25 - 0.50	0.50 - 1.00	Medium Stiff	Thumb penetrates about ¼ inch
10 - 30	Medium Dense	8 - 15	0.50 - 1.00	1.00 - 2.00	Stiff	Thumb penetrates less than ¼ inch
30 - 50	Dense	15 - 30	1.00 - 2.00	2.00 - 4.00	Very Stiff	Readily indented by thumbnail
>50	Very Dense	>30	>2.00	>4.00	Hard	Difficult to indent by thumbnail

Moisture Content				Structure		
Dry: Absence of moisture, dusty, dry to the touch Damp: Some moisture but leaves no moisture on hand Moist: Leaves moisture on hand Wet: Visible free water, likely from below water table				Blocky: Cohesive soil that can be broken down into small angular lumps Fissured: Breaks along definite fracture planes Homogeneous: Same color and appearance throughout Laminated: Alternating layers < 6 mm thick Lenses: Has small pockets of different soils, note thickness Slickensided: Striated, polished, or glossy fracture planes Stratified: Alternating layers of material or color >6 mm thick		
Plasticity	Dry Strength	Dilatancy	Toughness			
ML CL MH CH	Non to Low Low to Medium Medium to High Medium to High	Non to Low Medium to High Low to Medium High to Very High	Slow to Rapid None to Slow None to Slow None	Low, can't roll Medium Low to Medium High		

Unified Soil Classification Chart (Visual-Manual Procedure) (Similar to ASTM Designation D-2487)						
Major Divisions			Group Symbols		Typical Names	
Coarse Grained Soils: More than 50% retained on No. 200 sieve	Gravels: 50% or more retained on the No. 4 sieve	Clean Gravels	GW	Well-graded gravels and gravel/sand mixtures, little or no fines		
		Gravels with Fines	GP	Poorly-graded gravels and gravel/sand mixtures, little or no fines		
			GM	Silty gravels, gravel/sand/silt mixtures		
		Sands: More than 50% passing the No. 4 sieve	Clean Sands	SW	Well-graded sands and gravelly sands, little or no fines	
	SP			Poorly-graded sands and gravelly sands, little or no fines		
	Sands with Fines		SM	Silty sands, sand/silt mixtures		
			SC	Clayey sands, sand/clay mixtures		
	Fine-Grained Soils: 50% or more Passes No. 200 Sieve	Silt and Clays Low Plasticity Fines		ML	Inorganic silts, rock flour, clayey silts	
CL				Inorganic clays of low to medium plasticity, gravelly clays, sandy clays, lean clays		
OL				Organic silt and organic silty clays of low plasticity		
Silt and Clays High Plasticity Fines		MH	Inorganic silts, clayey silts			
		CH	Inorganic clays of high plasticity, fat clays			
		OH	Organic clays of medium to high plasticity			
Highly Organic Soils			PT	Peat, muck, and other highly organic soils		



*Additional References:*  
ASTM D2487 Standard Practice for Classification of Soils for Engineering Purposes and  
ASTM D2488 Standard Practice for Description and Identification of Soils (Visual-Manual Procedure)

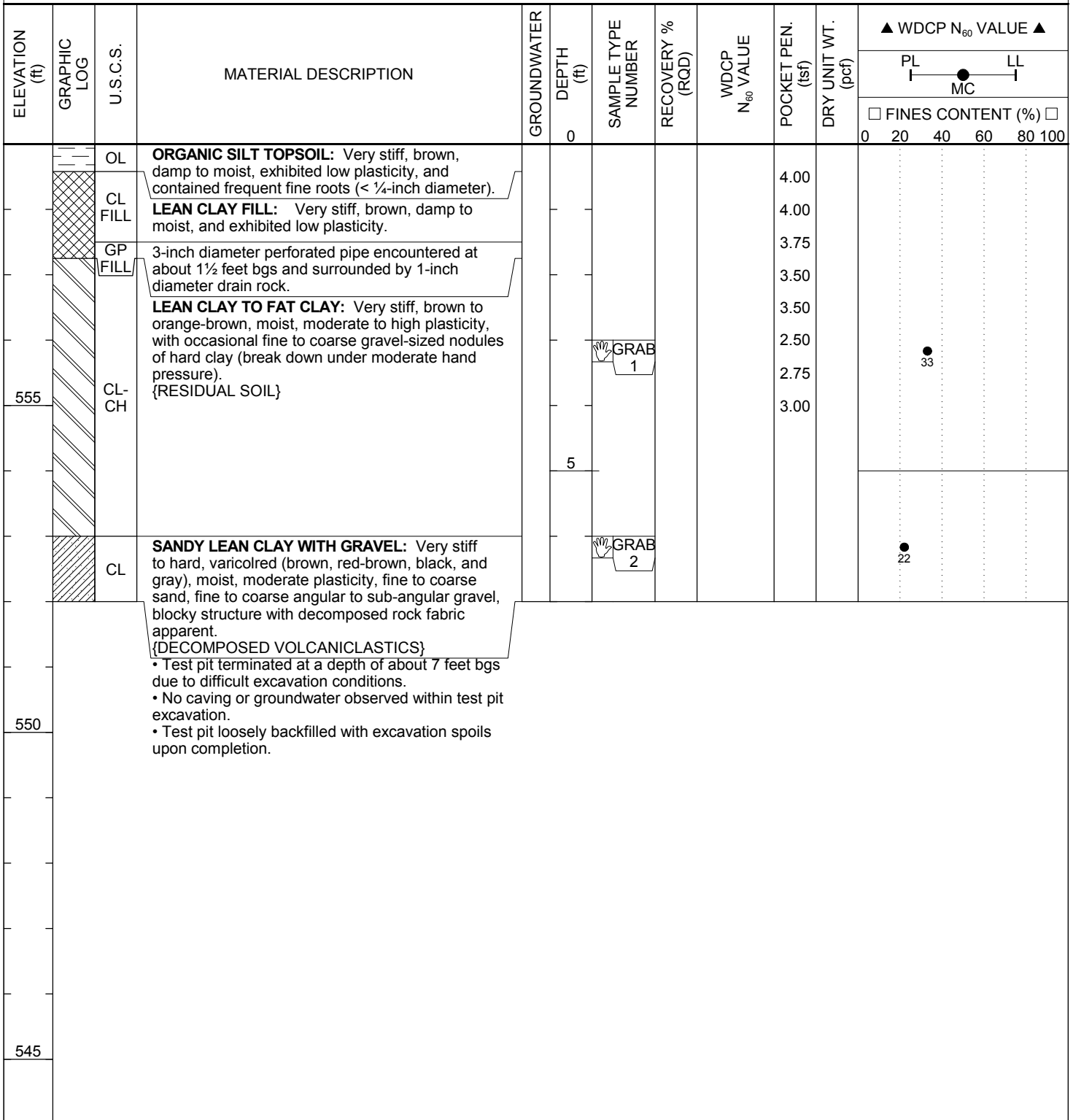


Carlson Geotechnical  
 7185 SW Sandburg Street, Suite 110  
 Tigard, Oregon 97223  
 Telephone: (503) 601-8250  
 Fax: (503) 601-8254

# FIGURE 5

## Test Pit TP-1

<b>CLIENT</b> West Linn Wilsonville School District	<b>PROJECT NAME</b> Sunset Primary School
<b>PROJECT NUMBER</b> G1504201	<b>PROJECT LOCATION</b> 2351 Oxford Street - West Linn, OR
<b>DATE STARTED</b> 6/18/15 <b>GROUND ELEVATION</b> 559 ft	<b>ELEVATION DATUM</b> See Figure 2
<b>EXCAVATION CONTRACTOR</b> CGT	<b>LOGGED BY</b> MDI/BLN <b>REVIEWED BY</b> JPQ
<b>EQUIPMENT</b> Case CX55B	<b>SEEPAGE</b> ---
<b>EXCAVATION METHOD</b> Test Pit	<b>GROUNDWATER AT END</b> ---
<b>NOTES</b>	<b>GROUNDWATER AFTER EXCAVATION</b> ---



CGT EXPLORATION WITH WDCP G1504201.GPJ GINT US.GDT 7/15/15



Carlson Geotechnical  
 7185 SW Sandburg Street, Suite 110  
 Tigard, Oregon 97223  
 Telephone: (503) 601-8250  
 Fax: (503) 601-8254

# FIGURE 6

## Test Pit TP-2

<b>CLIENT</b> West Linn Wilsonville School District	<b>PROJECT NAME</b> Sunset Primary School
<b>PROJECT NUMBER</b> G1504201	<b>PROJECT LOCATION</b> 2351 Oxford Street - West Linn, OR
<b>DATE STARTED</b> 6/18/15 <b>GROUND ELEVATION</b> 557 ft	<b>ELEVATION DATUM</b> See Figure 2
<b>EXCAVATION CONTRACTOR</b> CGT	<b>LOGGED BY</b> MDI/BLN <b>REVIEWED BY</b> JPQ
<b>EQUIPMENT</b> Case CX55B	<b>SEEPAGE</b> ---
<b>EXCAVATION METHOD</b> Test Pit	<b>GROUNDWATER AT END</b> ---
<b>NOTES</b>	<b>GROUNDWATER AFTER EXCAVATION</b> ---

ELEVATION (ft)	GRAPHIC LOG	U.S.C.S.	MATERIAL DESCRIPTION	GROUNDWATER DEPTH (ft)	SAMPLE TYPE NUMBER	RECOVERY % (RQD)	WDCP N <sub>60</sub> VALUE	POCKET PEN. (tsf)	DRY UNIT WT. (pcf)	▲ WDCP N <sub>60</sub> VALUE ▲	
										PL	LL
557		OL	<b>ORGANIC SILT TOPSOIL:</b> Very stiff, brown, damp to moist, exhibited low plasticity, and contained frequent fine roots (< 1/4-inch diameter).	0							
555		CL	<b>LEAN CLAY TO FAT CLAY:</b> Very stiff, brown to orange-brown, moist, moderate to high plasticity, with occasional fine to coarse gravel-sized nodules of hard clay (break down under moderate hand pressure). {RESIDUAL SOIL}		GRAB 1			3.00			25
550		CL	<b>SANDY LEAN CLAY WITH GRAVEL:</b> Very stiff to hard, varicolored (brown, red-brown, black, and gray), moist, moderate plasticity, fine to coarse sand, fine to coarse angular to sub-angular gravel, blocky structure with decomposed rock fabric apparent. {DECOMPOSED VOLCANICLASTICS}	5	GRAB 2			2.50			20
				10				2.50			

- Test pit terminated at a depth of about 10 feet bgs.
- No caving or groundwater observed within test pit excavation.
- Test pit loosely backfilled with excavation spoils upon completion.

CGT EXPLORATION WITH WDCP G1504201.GPJ GINT US.GDT 7/15/15





Carlson Geotechnical  
 7185 SW Sandburg Street, Suite 110  
 Tigard, Oregon 97223  
 Telephone: (503) 601-8250  
 Fax: (503) 601-8254

# FIGURE 7

## Test Pit TP-3

<b>CLIENT</b> West Linn Wilsonville School District	<b>PROJECT NAME</b> Sunset Primary School
<b>PROJECT NUMBER</b> G1504201	<b>PROJECT LOCATION</b> 2351 Oxford Street - West Linn, OR
<b>DATE STARTED</b> 6/18/15 <b>GROUND ELEVATION</b> 557 ft	<b>ELEVATION DATUM</b> See Figure 2
<b>EXCAVATION CONTRACTOR</b> CGT	<b>LOGGED BY</b> MDI/BLN <b>REVIEWED BY</b> JPQ
<b>EQUIPMENT</b> Case CX55B	<b>SEEPAGE</b> ---
<b>EXCAVATION METHOD</b> Test Pit	<b>GROUNDWATER AT END</b> ---
<b>NOTES</b>	<b>GROUNDWATER AFTER EXCAVATION</b> ---

ELEVATION (ft)	GRAPHIC LOG	U.S.C.S.	MATERIAL DESCRIPTION	GROUNDWATER DEPTH (ft)	SAMPLE TYPE NUMBER	RECOVERY % (RQD)	WDCP N <sub>60</sub> VALUE	POCKET PEN. (tsf)	DRY UNIT WT. (pcf)	▲ WDCP N <sub>60</sub> VALUE ▲	
										PL	LL
				0							0 20 40 60 80 100
		OL	<b>ORGANIC SILT TOPSOIL:</b> Very stiff, brown, damp to moist, exhibited low plasticity, and contained frequent fine roots (< ¼-inch diameter).					4.00			
		CL FILL	<b>LEAN CLAY FILL:</b> Very stiff, brown, damp to moist, and exhibited low plasticity.					4.00			● 27
555		GP FILL	3-inch diameter perforated pipe encountered at about 1½ feet bgs and surrounded by 1-inch diameter drain rock.					4.00			
		CL-CH	<b>LEAN CLAY TO FAT CLAY:</b> Very stiff, brown to orange-brown, moist, moderate to high plasticity, with occasional fine to coarse gravel-sized nodules of hard clay (break down under moderate hand pressure). {RESIDUAL SOIL}					3.50			
								3.00			
								3.00			
					GRAB 1			2.50			
550		CL	<b>SANDY LEAN CLAY WITH GRAVEL:</b> Very stiff to hard, varicolored (brown, red-brown, black, and gray), moist, moderate plasticity, fine to coarse sand, fine to coarse angular to sub-angular gravel, blocky structure with decomposed rock fabric apparent. {DECOMPOSED VOLCANICLASTICS}	5							
					GRAB 2						
				10							

- Test pit terminated at a depth of about 10 feet bgs.
- No caving or groundwater observed within test pit excavation.
- Test pit loosely backfilled with excavation spoils upon completion.

CGT EXPLORATION WITH WDCP G1504201.GPJ GINT US.GDT 7/15/15



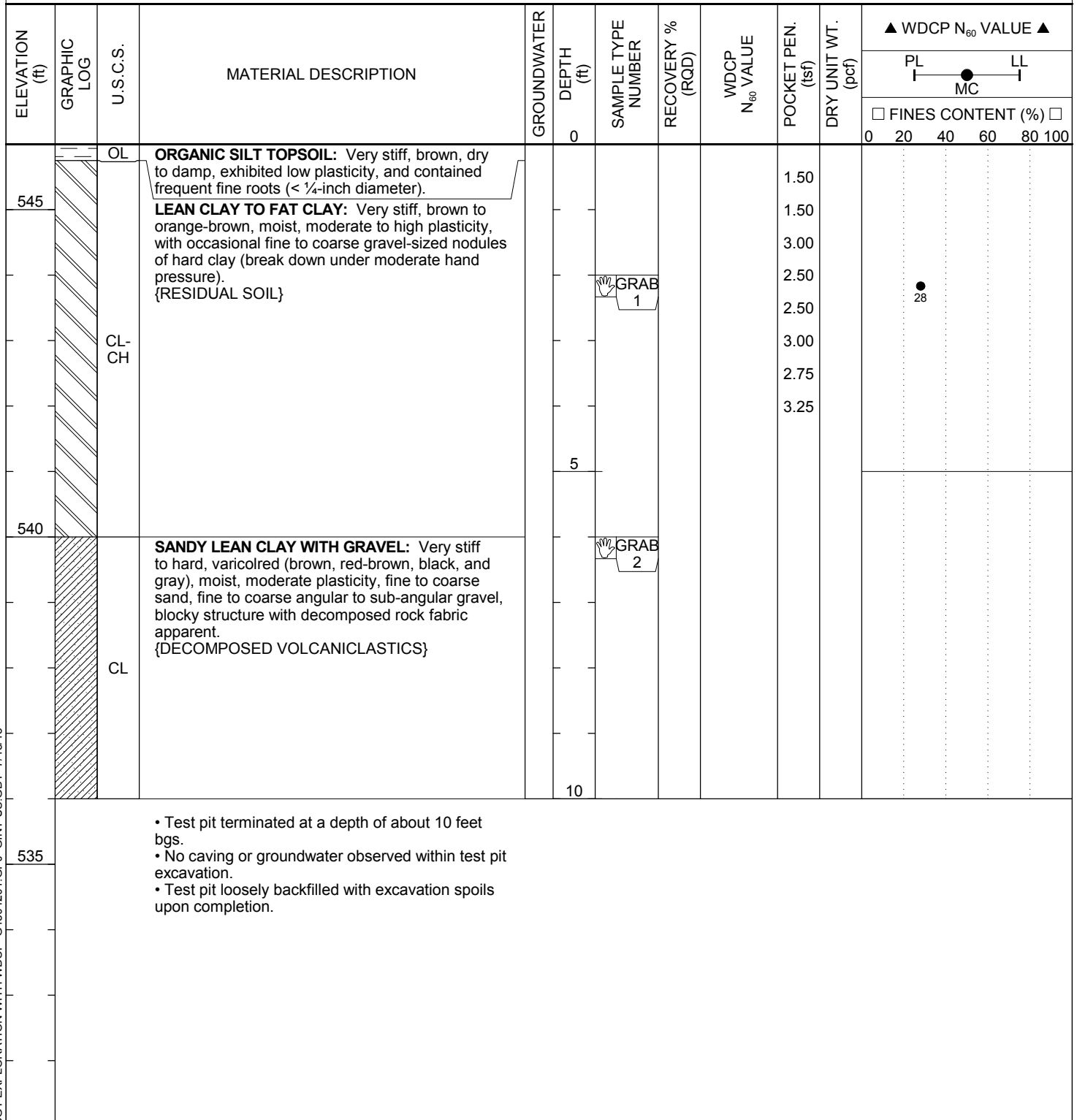


Carlson Geotechnical  
 7185 SW Sandburg Street, Suite 110  
 Tigard, Oregon 97223  
 Telephone: (503) 601-8250  
 Fax: (503) 601-8254

# FIGURE 9

## Test Pit TP-5

<b>CLIENT</b> West Linn Wilsonville School District	<b>PROJECT NAME</b> Sunset Primary School
<b>PROJECT NUMBER</b> G1504201	<b>PROJECT LOCATION</b> 2351 Oxford Street - West Linn, OR
<b>DATE STARTED</b> 6/18/15 <b>GROUND ELEVATION</b> 546 ft	<b>ELEVATION DATUM</b> See Figure 2
<b>EXCAVATION CONTRACTOR</b> CGT	<b>LOGGED BY</b> MDI/BLN <b>REVIEWED BY</b> JPQ
<b>EQUIPMENT</b> Case CX55B	<b>SEEPAGE</b> ---
<b>EXCAVATION METHOD</b> Test Pit	<b>GROUNDWATER AT END</b> ---
<b>NOTES</b> _____	<b>GROUNDWATER AFTER EXCAVATION</b> ---



CGT EXPLORATION WITH WDCP: G1504201.GPJ GINT US.GDT 7/15/15



Carlson Geotechnical  
 7185 SW Sandburg Street, Suite 110  
 Tigard, Oregon 97223  
 Telephone: (503) 601-8250  
 Fax: (503) 601-8254

# FIGURE 10

## Test Pit TP-6 / IT-6

<b>CLIENT</b> West Linn Wilsonville School District	<b>PROJECT NAME</b> Sunset Primary School
<b>PROJECT NUMBER</b> G1504201	<b>PROJECT LOCATION</b> 2351 Oxford Street - West Linn, OR
<b>DATE STARTED</b> 6/18/15 <b>GROUND ELEVATION</b> 548 ft	<b>ELEVATION DATUM</b> See Figure 2
<b>EXCAVATION CONTRACTOR</b> CGT	<b>LOGGED BY</b> MDI/BLN <b>REVIEWED BY</b> JPQ
<b>EQUIPMENT</b> Case CX55B	<b>SEEPAGE</b> ---
<b>EXCAVATION METHOD</b> Test Pit & Infiltration Test	<b>GROUNDWATER AT END</b> ---
<b>NOTES</b>	<b>GROUNDWATER AFTER EXCAVATION</b> ---

ELEVATION (ft)	GRAPHIC LOG	U.S.C.S.	MATERIAL DESCRIPTION	GROUNDWATER	DEPTH (ft)	SAMPLE TYPE NUMBER	RECOVERY % (RQD)	WDCP N <sub>60</sub> VALUE	POCKET PEN. (tsf)	DRY UNIT WT. (pcf)	▲ WDCP N <sub>60</sub> VALUE ▲	
											PL	LL
					0							0 20 40 60 80 100
		OL	<b>ORGANIC SILT TOPSOIL:</b> Very stiff, brown, dry to damp, exhibited low plasticity, and contained frequent fine roots (< 1/4-inch diameter).						2.25			
545		CL-CH	<b>LEAN CLAY TO FAT CLAY:</b> Very stiff, brown to orange-brown, moist, moderate to high plasticity, with occasional fine to coarse gravel-sized nodules of hard clay (break down under moderate hand pressure), trace roots (up to about 1/4-inch in diameter) observed to about 2 3/4 feet bgs. {RESIDUAL SOIL}						3.00			
									3.00			
									3.25			
									3.00			
									2.50			
									2.50			
									3.25			
					5	GRAB 1						23 48 25 1

- Test pit terminated at a depth of about 5 feet bgs.
- Infiltration test (IT-6) performed in excavation at about 5 feet bgs (see Appendix A for results).
- No caving or groundwater observed within test pit excavation.
- Test pit loosely backfilled with excavation spoils upon completion.

CGT EXPLORATION WITH WDCP G1504201.GPJ GINT US.GDT 7/15/15

540

535



Carlson Geotechnical  
 7185 SW Sandburg Street, Suite 110  
 Tigard, Oregon 97223  
 Telephone: (503) 601-8250  
 Fax: (503) 601-8254

# FIGURE 11

## Test Pit TP-7 / IT-2

<b>CLIENT</b> <u>West Linn Wilsonville School District</u>	<b>PROJECT NAME</b> <u>Sunset Primary School</u>
<b>PROJECT NUMBER</b> <u>G1504201</u>	<b>PROJECT LOCATION</b> <u>2351 Oxford Street - West Linn, OR</u>
<b>DATE STARTED</b> <u>6/18/15</u> <b>GROUND ELEVATION</b> <u>555 ft</u>	<b>ELEVATION DATUM</b> <u>See Figure 2</u>
<b>EXCAVATION CONTRACTOR</b> <u>CGT</u>	<b>LOGGED BY</b> <u>MDI/BLN</u> <b>REVIEWED BY</b> <u>JPQ</u>
<b>EQUIPMENT</b> <u>Case CX55B</u>	<b>SEEPAGE</b> <u>---</u>
<b>EXCAVATION METHOD</b> <u>Test Pit &amp; Infiltration Test</u>	<b>GROUNDWATER AT END</b> <u>---</u>
<b>NOTES</b> _____	<b>GROUNDWATER AFTER EXCAVATION</b> <u>---</u>

ELEVATION (ft)	GRAPHIC LOG	U.S.C.S.	MATERIAL DESCRIPTION	GROUNDWATER DEPTH (ft)	SAMPLE TYPE NUMBER	RECOVERY % (RQD)	WDCP N <sub>60</sub> VALUE	POCKET PEN. (tsf)	DRY UNIT WT. (pcf)	▲ WDCP N <sub>60</sub> VALUE ▲	
										PL	LL
				0							MC
											0 20 40 60 80 100
	CL FILL		<b>LEAN CLAY FILL:</b> Dark brown, dry to damp, exhibited low plasticity, with angular/subangular gravel up to 1 inch diameter and pieces of asphaltic concrete up to 1 foot diameter.  2 inch diameter PVC pipe at about 1½ feet bgs.								
550	CL-CH		<b>LEAN CLAY TO FAT CLAY:</b> Very stiff, brown to orange-brown, moist, moderate to high plasticity, with occasional fine to coarse gravel-sized nodules of hard clay (break down under moderate hand pressure). {RESIDUAL SOIL}	5	GRAB 1						33

- Test pit terminated at a depth of about 5 feet bgs.
- Infiltration test (IT-2) performed in excavation at about 5 feet bgs (see Appendix A for results).
- No caving or groundwater observed within test pit excavation.
- Test pit loosely backfilled with excavation spoils upon completion.

CGT EXPLORATION WITH WDCP G1504201.GPJ GINT US.GDT 7/15/15

545

540



Carlson Geotechnical  
 7185 SW Sandburg Street, Suite 110  
 Tigard, Oregon 97223  
 Telephone: (503) 601-8250  
 Fax: (503) 601-8254

# FIGURE 12

## Test Pit TP-8 / IT-3

<b>CLIENT</b> West Linn Wilsonville School District	<b>PROJECT NAME</b> Sunset Primary School
<b>PROJECT NUMBER</b> G1504201	<b>PROJECT LOCATION</b> 2351 Oxford Street - West Linn, OR
<b>DATE STARTED</b> 6/18/15 <b>GROUND ELEVATION</b> 547 ft	<b>ELEVATION DATUM</b> See Figure 2
<b>EXCAVATION CONTRACTOR</b> CGT	<b>LOGGED BY</b> MDI/BLN <b>REVIEWED BY</b> JPQ
<b>EQUIPMENT</b> Case CX55B	<b>SEEPAGE</b> ---
<b>EXCAVATION METHOD</b> Test Pit & Infiltration Test	<b>GROUNDWATER AT END</b> ---
<b>NOTES</b>	<b>GROUNDWATER AFTER EXCAVATION</b> ---

ELEVATION (ft)	GRAPHIC LOG	U.S.C.S.	MATERIAL DESCRIPTION	GROUNDWATER	DEPTH (ft)	SAMPLE TYPE NUMBER	RECOVERY % (RQD)	WDCP N <sub>60</sub> VALUE	POCKET PEN. (tsf)	DRY UNIT WT. (pcf)	▲ WDCP N <sub>60</sub> VALUE ▲	
											PL	LL
					0							0 20 40 60 80 100
545		OL	<b>ORGANIC SILT TOPSOIL:</b> Very stiff, brown, dry to damp, exhibited low plasticity, and contained frequent fine roots (< 1/4-inch diameter).						4.50			
		CL-CH	<b>LEAN CLAY TO FAT CLAY:</b> Very stiff, brown to orange-brown, dry to damp, moderate to high plasticity, with occasional fine to coarse gravel-sized nodules of hard clay (break down under moderate hand pressure). {RESIDUAL SOIL} Moist below about 2 feet bgs.						4.50			
						GRAB 1			3.00			
									3.00			31

- Test pit terminated at a depth of about 4 feet bgs.
- Infiltration test (IT-3) performed in excavation at about 4 feet bgs (see Appendix A for results).
- No caving or groundwater observed within test pit excavation.
- Test pit loosely backfilled with excavation spoils upon completion.

CGT EXPLORATION WITH WDCP G1504201.GPJ GINT US.GDT 7/15/15



Carlson Geotechnical  
 7185 SW Sandburg Street, Suite 110  
 Tigard, Oregon 97223  
 Telephone: (503) 601-8250  
 Fax: (503) 601-8254

# FIGURE 13

## Test Pit TP-9 / IT-4

<b>CLIENT</b> West Linn Wilsonville School District	<b>PROJECT NAME</b> Sunset Primary School
<b>PROJECT NUMBER</b> G1504201	<b>PROJECT LOCATION</b> 2351 Oxford Street - West Linn, OR
<b>DATE STARTED</b> 6/18/15 <b>GROUND ELEVATION</b> 559 ft	<b>ELEVATION DATUM</b> See Figure 2
<b>EXCAVATION CONTRACTOR</b> CGT	<b>LOGGED BY</b> MDI/BLN <b>REVIEWED BY</b> JPQ
<b>EQUIPMENT</b> Case CX55B	<b>SEEPAGE</b> ---
<b>EXCAVATION METHOD</b> Test Pit & Infiltration Test	<b>GROUNDWATER AT END</b> ---
<b>NOTES</b>	<b>GROUNDWATER AFTER EXCAVATION</b> ---

ELEVATION (ft)	GRAPHIC LOG	U.S.C.S.	MATERIAL DESCRIPTION	GROUNDWATER DEPTH (ft)	SAMPLE TYPE NUMBER	RECOVERY % (RQD)	WDCP N <sub>60</sub> VALUE	POCKET PEN. (tsf)	DRY UNIT WT. (pcf)	▲ WDCP N <sub>60</sub> VALUE ▲	
										PL	LL
				0						<input type="checkbox"/> FINES CONTENT (%) <input type="checkbox"/> 0 20 40 60 80 100	
		OL	<b>ORGANIC SILT TOPSOIL:</b> Very stiff, brown, dry to damp, exhibited low plasticity, and contained frequent fine roots (< 1/4-inch diameter).					4.50			
		CL-CH	<b>LEAN CLAY TO FAT CLAY:</b> Very stiff, brown to orange-brown, damp, moderate to high plasticity, with occasional fine to coarse gravel-sized nodules of hard clay (break down under moderate hand pressure). {RESIDUAL SOIL}					4.00			
								4.00			
								3.00			
								3.00			
555		CL	<b>SANDY LEAN CLAY WITH GRAVEL:</b> Very stiff to hard, varicolored (brown, red-brown, black, tan, and gray), moist, moderate plasticity, fine to coarse sand, fine to coarse angular to sub-angular gravel, blocky structure with decomposed rock fabric apparent. {DECOMPOSED VOLCANICLASTICS}	5	GRAB 1						29

- Test pit terminated at a depth of about 5 feet bgs.
- Infiltration test (IT-4) performed in excavation at about 5 feet bgs (see Appendix A for results).
- No caving or groundwater observed within test pit excavation.
- Test pit loosely backfilled with excavation spoils upon completion.

CGT EXPLORATION WITH WDCP G1504201.GPJ GINT US.GDT 7/15/15

550

545



Carlson Geotechnical  
 7185 SW Sandburg Street, Suite 110  
 Tigard, Oregon 97223  
 Telephone: (503) 601-8250  
 Fax: (503) 601-8254

# FIGURE 14

## Test Pit TP-10 / IT-5

<b>CLIENT</b> West Linn Wilsonville School District	<b>PROJECT NAME</b> Sunset Primary School
<b>PROJECT NUMBER</b> G1504201	<b>PROJECT LOCATION</b> 2351 Oxford Street - West Linn, OR
<b>DATE STARTED</b> 6/18/15 <b>GROUND ELEVATION</b> 554 ft	<b>ELEVATION DATUM</b> See Figure 2
<b>EXCAVATION CONTRACTOR</b> CGT	<b>LOGGED BY</b> MDI/BLN <b>REVIEWED BY</b> JPQ
<b>EQUIPMENT</b> Case CX55B	<b>SEEPAGE</b> ---
<b>EXCAVATION METHOD</b> Test Pit & Infiltration Test	<b>GROUNDWATER AT END</b> ---
<b>NOTES</b>	<b>GROUNDWATER AFTER EXCAVATION</b> ---

ELEVATION (ft)	GRAPHIC LOG	U.S.C.S.	MATERIAL DESCRIPTION	GROUNDWATER DEPTH (ft)	SAMPLE TYPE NUMBER	RECOVERY % (RQD)	WDCP N <sub>60</sub> VALUE	POCKET PEN. (tsf)	DRY UNIT WT. (pcf)	▲ WDCP N <sub>60</sub> VALUE ▲	
										PL	LL
550		OL	<b>ORGANIC SILT TOPSOIL:</b> Very stiff, brown, dry to damp, exhibited low plasticity, and contained frequent fine roots (< 1/4-inch diameter).	0							
		CL-CH	<b>LEAN CLAY TO FAT CLAY:</b> Very stiff, brown to orange-brown, damp, moderate to high plasticity, with occasional fine to coarse gravel-sized nodules of hard clay (break down under moderate hand pressure). {RESIDUAL SOIL} Moist below about 2 feet bgs.		GRAB 1			3.50			
								4.00			18
								4.00			
								4.00			
								2.75			
								3.50			
								3.75			
								3.75			
				5	GRAB 2						31

- Test pit terminated at a depth of about 5 feet bgs.
- Infiltration test (IT-5) performed in excavation at about 5 feet bgs.
- No caving or groundwater observed within test pit excavation.
- Test pit loosely backfilled with excavation spoils upon completion.

CGT EXPLORATION WITH WDCP G1504201.GPJ GINT US.GDT 7/15/15

545

540



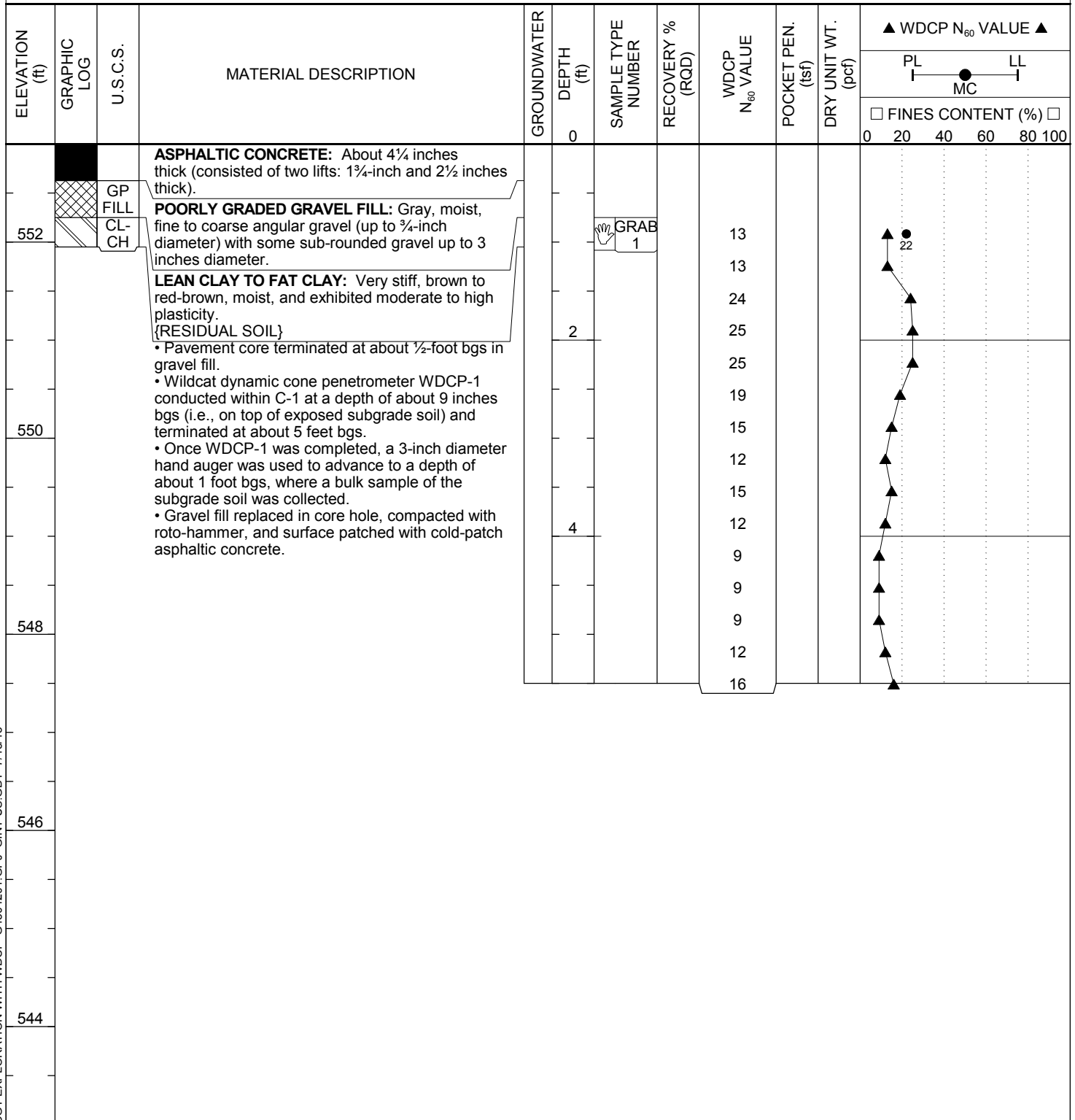


Carlson Geotechnical  
 7185 SW Sandburg Street, Suite 110  
 Tigard, Oregon 97223  
 Telephone: (503) 601-8250  
 Fax: (503) 601-8254

# FIGURE 15

## Boring C-1/DCP-1

<b>CLIENT</b> West Linn Wilsonville School District	<b>PROJECT NAME</b> Sunset Primary School
<b>PROJECT NUMBER</b> G1504201	<b>PROJECT LOCATION</b> 2351 Oxford Street - West Linn, OR
<b>DATE STARTED</b> 6/19/15 <b>GROUND ELEVATION</b> 553 ft	<b>ELEVATION DATUM</b> See Figure 2
<b>DRILLING CONTRACTOR</b> CGT	<b>LOGGED BY</b> MDI/BLN <b>REVIEWED BY</b> JPQ
<b>EQUIPMENT</b> Coring Machine/HA/WDCP	<b>SEEPAGE</b> ---
<b>DRILLING METHOD</b> Coring, Hand Auger & WDCP	<b>GROUNDWATER AT END</b> ---
<b>NOTES</b>	<b>GROUNDWATER AFTER DRILLING</b> ---



CGT EXPLORATION WITH WDCP G1504201.GPJ GINT US.GDT 7/15/15



Carlson Geotechnical  
 7185 SW Sandburg Street, Suite 110  
 Tigard, Oregon 97223  
 Telephone: (503) 601-8250  
 Fax: (503) 601-8254

# FIGURE 16

## Boring C-2/DCP-2

<b>CLIENT</b> West Linn Wilsonville School District	<b>PROJECT NAME</b> Sunset Primary School
<b>PROJECT NUMBER</b> G1504201	<b>PROJECT LOCATION</b> 2351 Oxford Street - West Linn, OR
<b>DATE STARTED</b> 6/19/15 <b>GROUND ELEVATION</b> 555 ft	<b>ELEVATION DATUM</b> See Figure 2
<b>DRILLING CONTRACTOR</b> CGT	<b>LOGGED BY</b> MDI/BLN <b>REVIEWED BY</b> JPQ
<b>EQUIPMENT</b> Coring Machine/HA/WDCP	<b>SEEPAGE</b> ---
<b>DRILLING METHOD</b> Coring, Hand Auger & WDCP	<b>GROUNDWATER AT END</b> ---
<b>NOTES</b>	<b>GROUNDWATER AFTER DRILLING</b> ---

ELEVATION (ft)	GRAPHIC LOG	U.S.C.S.	MATERIAL DESCRIPTION	GROUNDWATER	DEPTH (ft)	SAMPLE TYPE NUMBER	RECOVERY % (RQD)	WDCP N <sub>60</sub> VALUE	POCKET PEN. (tsf)	DRY UNIT WT. (pcf)	▲ WDCP N <sub>60</sub> VALUE ▲	
											PL	LL
554		GP FILL	<p><b>ASPHALTIC CONCRETE:</b> About 5 inches thick (single lift).</p> <p><b>POORLY GRADED GRAVEL FILL:</b> Gray, moist, angular, and fine (up to 3/4-inches diameter).</p>		0							

552

- Pavement core terminated at about 1/2-foot bgs in gravel fill.
- Attempted to advance through gravel fill with rotary hammer drill, but encountered gravel to a depth of about 22 inches (the maximum depth to which rotary hammer drill could advance).
- Gravel fill replaced in core hole, compacted with roto-hammer, and surface patched with cold-patch asphaltic concrete.

550

548

546

CGT EXPLORATION WITH WDCP G1504201.GPJ GINT US.GDT 7/15/15

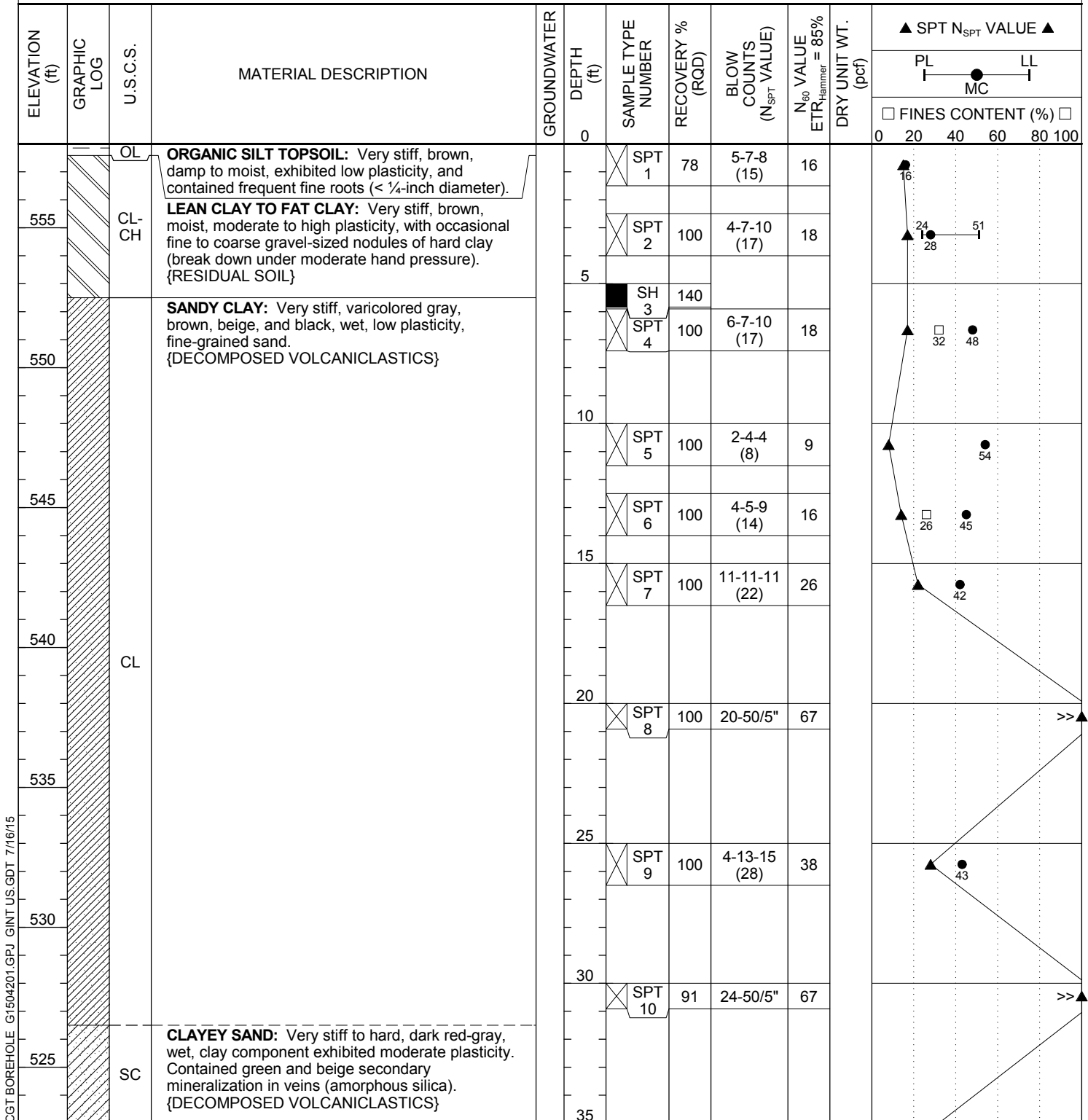


Carlson Geotechnical  
 7185 SW Sandburg Street, Suite 110  
 Tigard, Oregon 97223  
 Telephone: (503) 601-8250  
 Fax: (503) 601-8254

# FIGURE 17

## Boring B-1

<b>CLIENT</b> West Linn Wilsonville School District	<b>PROJECT NAME</b> Sunset Primary School
<b>PROJECT NUMBER</b> G1504201	<b>PROJECT LOCATION</b> 2351 Oxford Street - West Linn, OR
<b>DATE STARTED</b> 6/22/15 <b>GROUND ELEVATION</b> 558 ft	<b>ELEVATION DATUM</b> See Figure 2
<b>DRILLING CONTRACTOR</b> Western States Soil Conservation	<b>LOGGED BY</b> JAJ <b>REVIEWED BY</b> JPQ
<b>EQUIPMENT</b> CME 75 HT Truck-mounted Drill Rig	<b>SEEPAGE</b> ---
<b>DRILLING METHOD</b> Mud Rotary	<b>GROUNDWATER AT END</b> ---
<b>NOTES</b>	<b>GROUNDWATER AFTER DRILLING</b> ---



(Continued Next Page)

CGT BOREHOLE G1504201.GPJ GINT US.GDT 7/16/15



Carlson Geotechnical  
 7185 SW Sandburg Street, Suite 110  
 Tigard, Oregon 97223  
 Telephone: (503) 601-8250  
 Fax: (503) 601-8254

# FIGURE 17

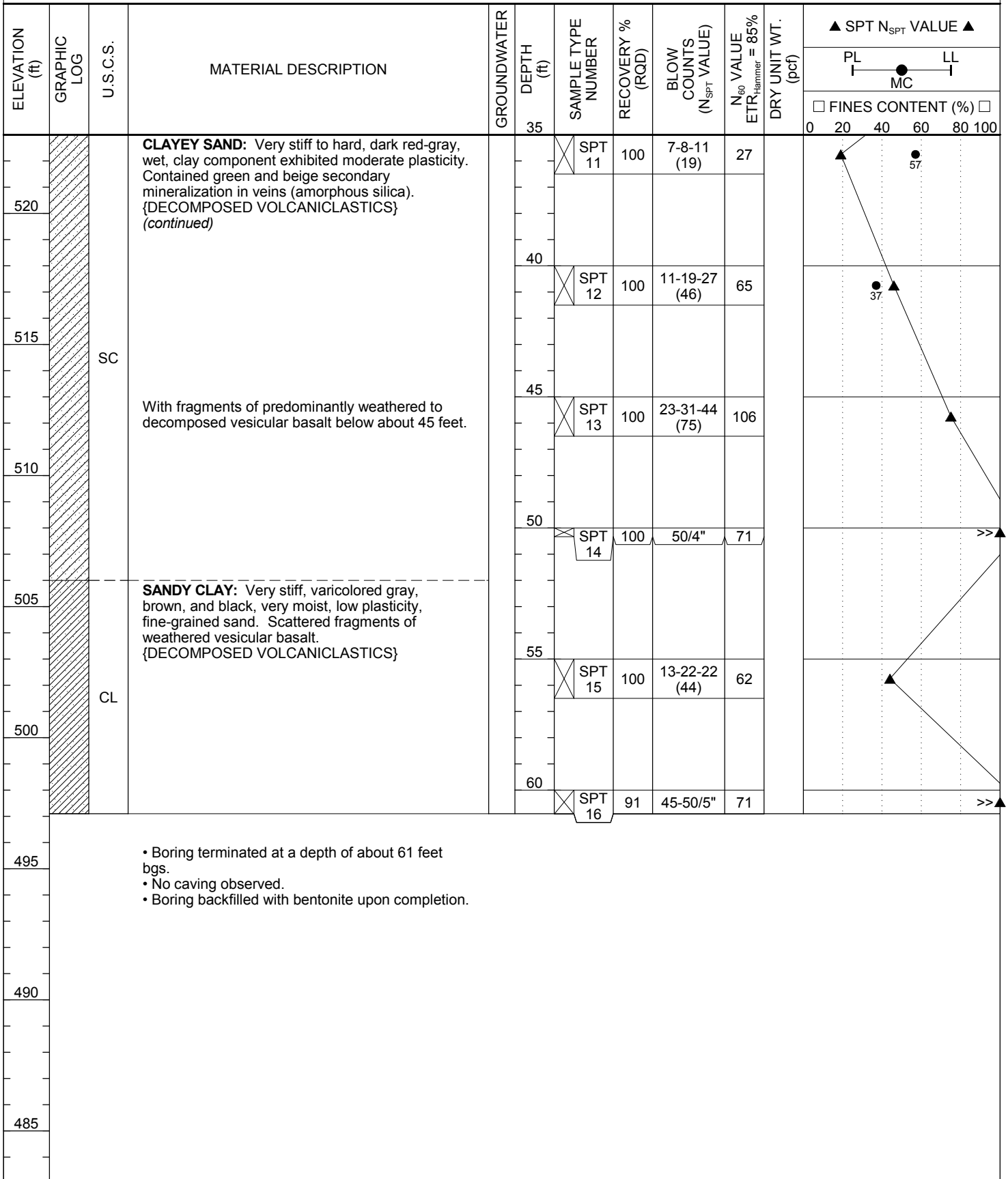
## Boring B-1

CLIENT West Linn Wilsonville School District

PROJECT NAME Sunset Primary School

PROJECT NUMBER G1504201

PROJECT LOCATION 2351 Oxford Street - West Linn, OR



CGT BOREHOLE G1504201.GPJ GINT US.GDT 7/16/15

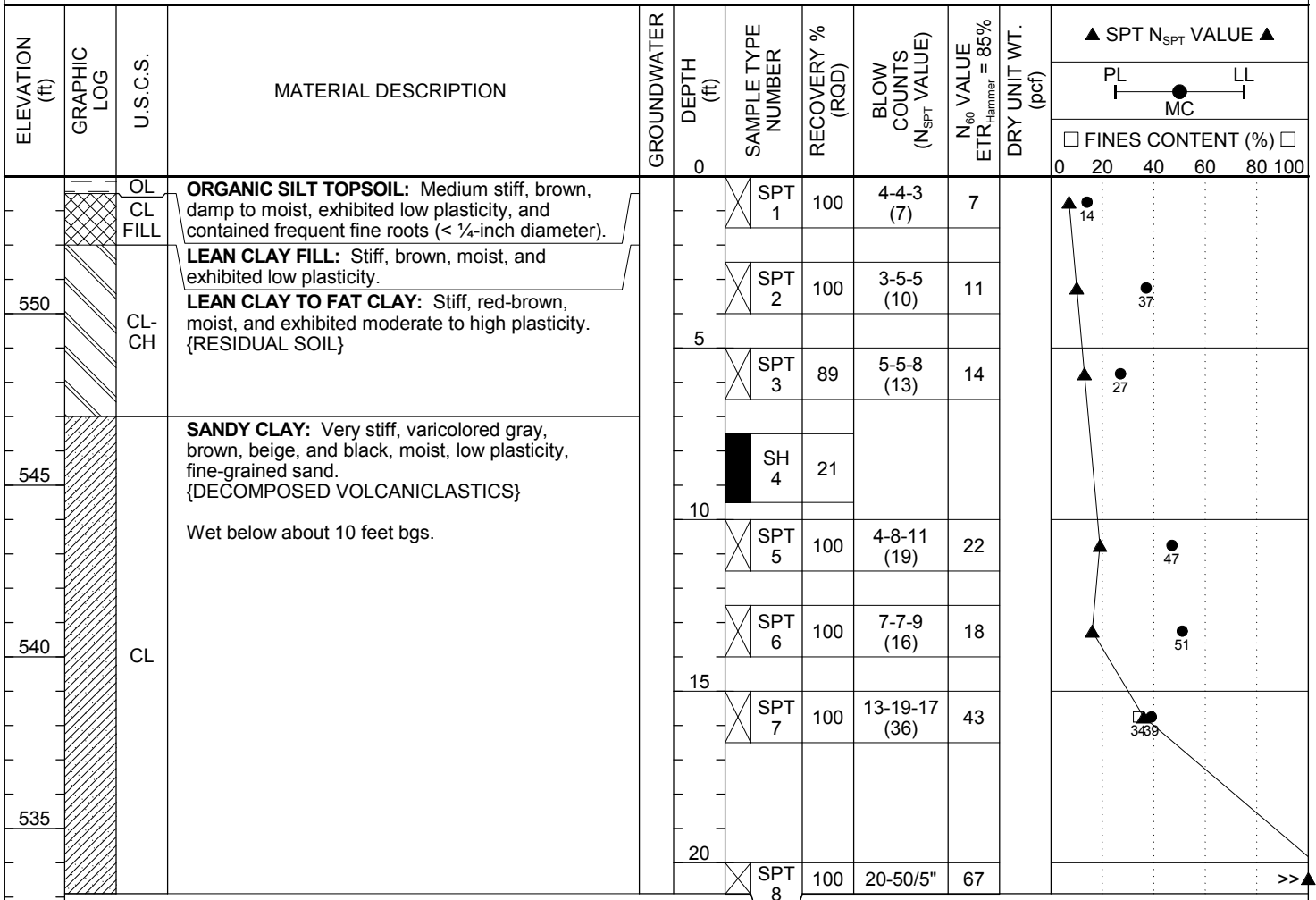


Carlson Geotechnical  
 7185 SW Sandburg Street, Suite 110  
 Tigard, Oregon 97223  
 Telephone: (503) 601-8250  
 Fax: (503) 601-8254

# FIGURE 18

## Boring B-2

<b>CLIENT</b> West Linn Wilsonville School District	<b>PROJECT NAME</b> Sunset Primary School
<b>PROJECT NUMBER</b> G1504201	<b>PROJECT LOCATION</b> 2351 Oxford Street - West Linn, OR
<b>DATE STARTED</b> 6/26/15 <b>GROUND ELEVATION</b> 554 ft	<b>ELEVATION DATUM</b> See Figure 2
<b>DRILLING CONTRACTOR</b> Western States Soil Conservation	<b>LOGGED BY</b> JAJ <b>REVIEWED BY</b> JPQ
<b>EQUIPMENT</b> CME 75 HT Truck-mounted Drill Rig	<b>SEEPAGE</b> ---
<b>DRILLING METHOD</b> Mud Rotary	<b>GROUNDWATER AT END</b> ---
<b>NOTES</b>	<b>GROUNDWATER AFTER DRILLING</b> ---



- Boring terminated at a depth of about 21 feet bgs.
- No caving observed.
- Boring backfilled with bentonite upon completion.

CGT BOREHOLE G1504201.GPJ GINT US.GDT 7/16/15

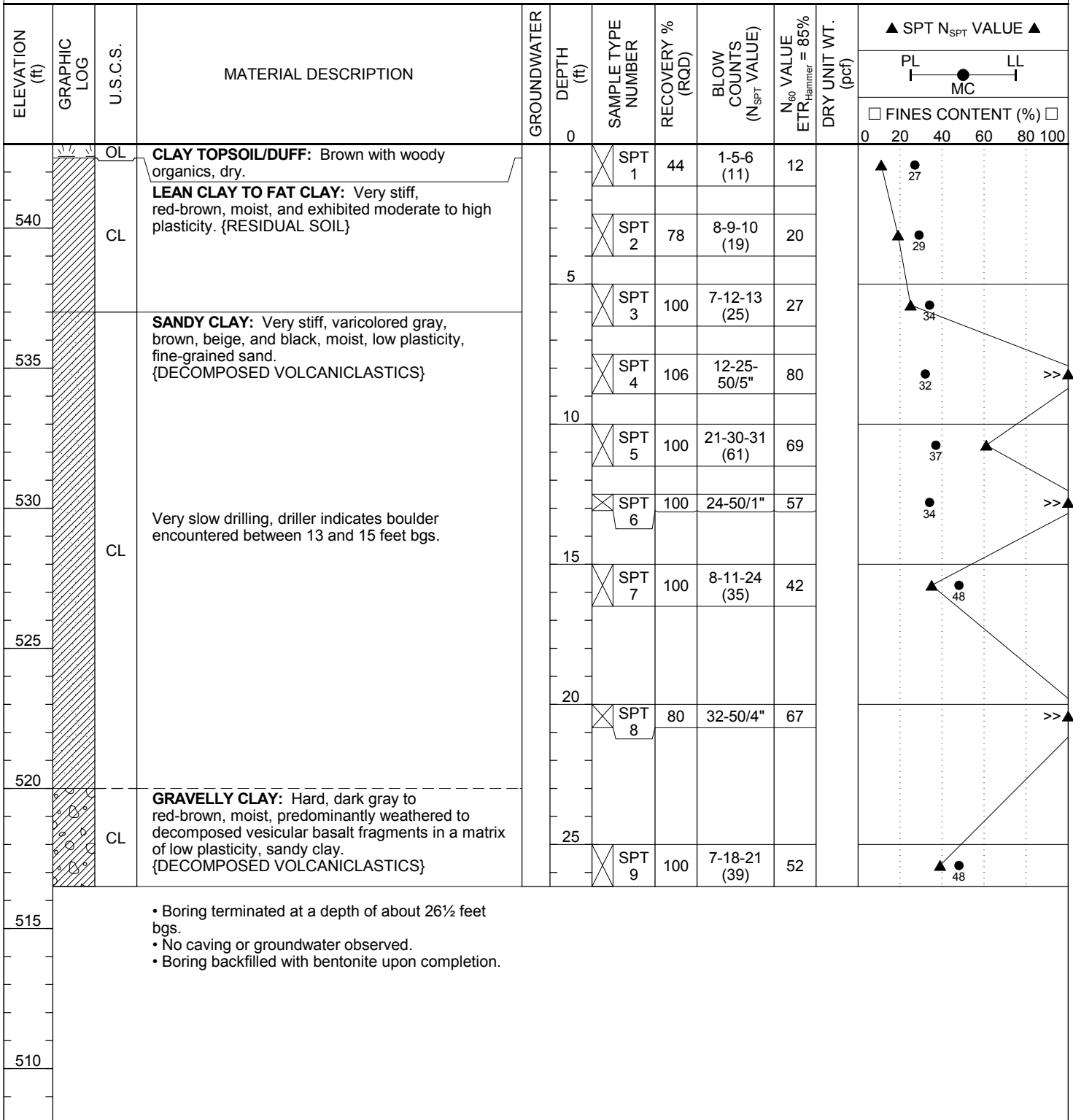


Carlson Geotechnical  
 7185 SW Sandburg Street, Suite 110  
 Tigard, Oregon 97223  
 Telephone: (503) 601-8250  
 Fax: (503) 601-8254

# FIGURE 19

## Boring B-3

<b>CLIENT</b> West Linn Wilsonville School District	<b>PROJECT NAME</b> Sunset Primary School
<b>PROJECT NUMBER</b> G1504201	<b>PROJECT LOCATION</b> 2351 Oxford Street - West Linn, OR
<b>DATE STARTED</b> 6/26/15 <b>GROUND ELEVATION</b> 543 ft	<b>ELEVATION DATUM</b> See Figure 2
<b>DRILLING CONTRACTOR</b> Western States Soil Conservation	<b>LOGGED BY</b> JAJ <b>REVIEWED BY</b> JPQ
<b>EQUIPMENT</b> CME 75 HT Truck-mounted Drill Rig	<b>SEEPAGE</b> ---
<b>DRILLING METHOD</b> Mud Rotary	<b>GROUNDWATER AT END</b> ---
<b>NOTES</b>	<b>GROUNDWATER AFTER DRILLING</b> ---



CGT BOREHOLE G1504201.GPJ GINT US.GDT 7/16/15



Carlson Geotechnical  
 7185 SW Sandburg Street, Suite 110  
 Tigard, Oregon 97223  
 Telephone: (503) 601-8250  
 Fax: (503) 601-8254

# FIGURE 20

## Boring B-4 / IT-1

<b>CLIENT</b> West Linn Wilsonville School District	<b>PROJECT NAME</b> Sunset Primary School
<b>PROJECT NUMBER</b> G1504201	<b>PROJECT LOCATION</b> 2351 Oxford Street - West Linn, OR
<b>DATE STARTED</b> 6/22/15 <b>GROUND ELEVATION</b> 555 ft	<b>ELEVATION DATUM</b> See Figure 2
<b>DRILLING CONTRACTOR</b> Western States Soil Conservation	<b>LOGGED BY</b> MDI <b>REVIEWED BY</b> JPQ
<b>EQUIPMENT</b> WS45 Track	<b>SEEPAGE</b> ---
<b>DRILLING METHOD</b> Hollow Stem Auger	<b>GROUNDWATER AT END</b> ---
<b>NOTES</b> 6 inch PVC pipe inserted in borehole once auger was removed.	<b>GROUNDWATER AFTER DRILLING</b> ---

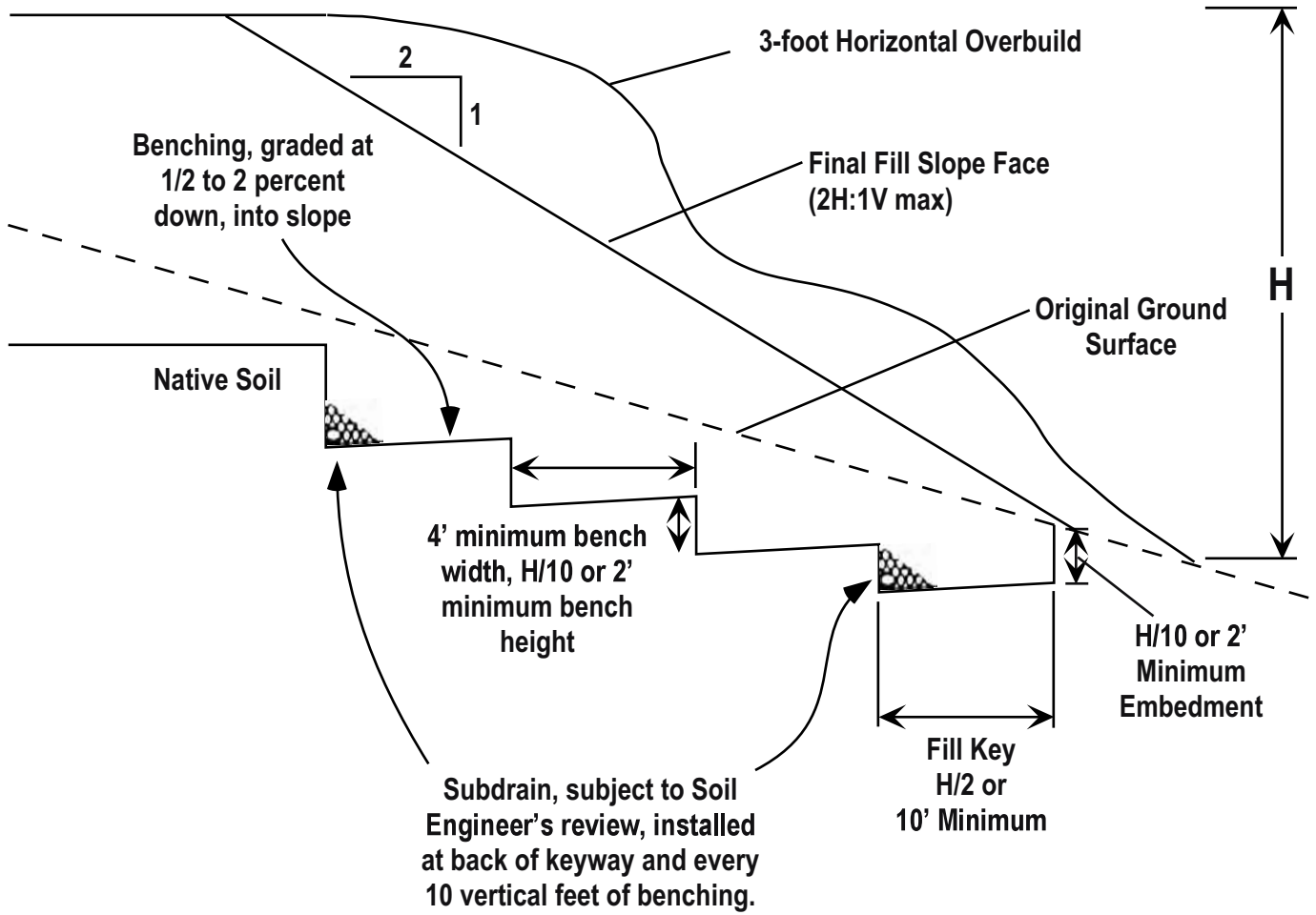
ELEVATION (ft)	GRAPHIC LOG	U.S.C.S.	MATERIAL DESCRIPTION	GROUNDWATER	DEPTH (ft)	SAMPLE TYPE NUMBER	RECOVERY % (RQD)	BLOW COUNTS (N <sub>SPT</sub> VALUE)	N <sub>60</sub> VALUE	DRY UNIT WT. (pcf)	▲ SPT N <sub>SPT</sub> VALUE ▲	
											PL	LL
					0						<input type="checkbox"/> FINES CONTENT (%) <input type="checkbox"/> 0 20 40 60 80 100	
	GP FILL		<b>ASPHALTIC CONCRETE:</b> About 3¾ inches thick.									
	GP FILL		<b>GRAVEL FILL:</b> Gray, moist, angular, fine to coarse, with some sub-rounded gravel up to 3 inches diameter.									
	CL		<b>LEAN CLAY TO FAT CLAY:</b> Brown, damp to moist, moderate to high plasticity, with occasional fine to coarse gravel-sized nodules of hard clay (break down under moderate hand pressure). {RESIDUAL SOIL}									
550					5	GRAB 1						

- Boring terminated at a depth of about 5 feet bgs.
- Infiltration test (IT-1) performed in borehole at about 5 feet bgs (see Appendix A for results).
- No caving or groundwater observed within borehole.
- Borehole backfilled with bentonite upon completion and surface patched with cold patch asphalt.

CGT BOREHOLE G1504201.GPJ GINT US.GDT 7/16/15

545

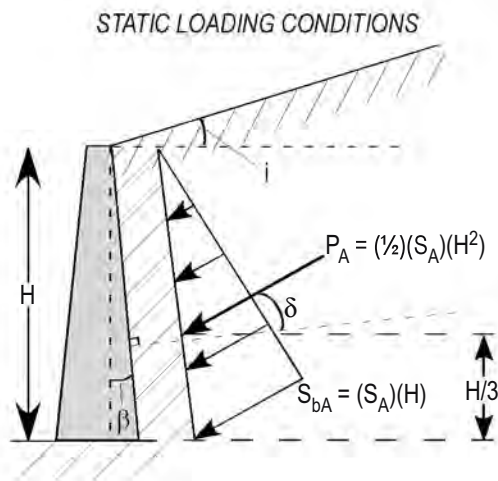
540



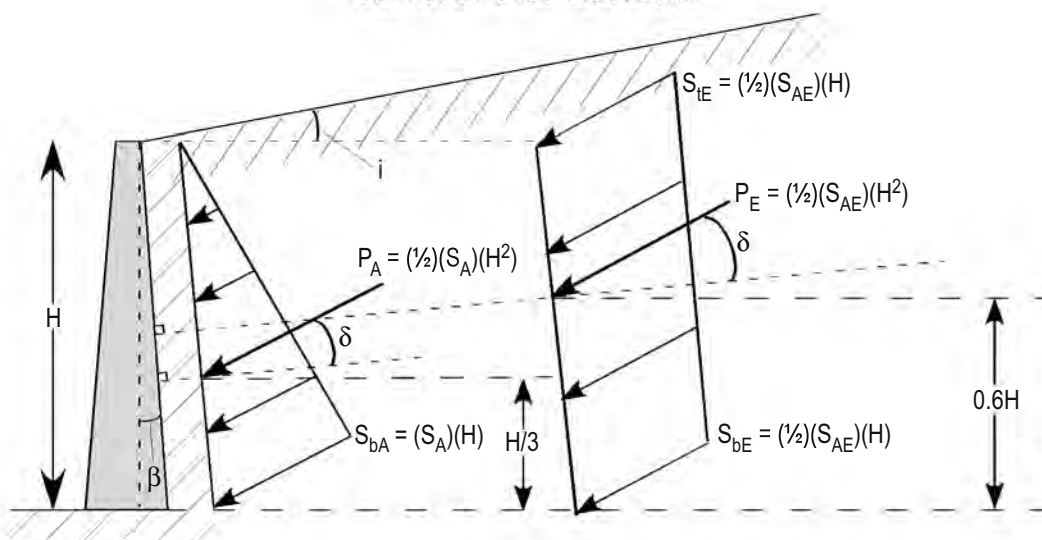
NOTE: Surfaces to receive fill with slopes steeper than 5H:1V (horizontal:vertical) should be benched and keyed as shown.



ACTIVE LATERAL PRESSURE DISTRIBUTION



SEISMIC LOADING CONDITIONS



LEGEND

$P_A$  = Static active thrust force acting at a triangular distribution on wall (lb/ft<sup>3</sup>)

$P_E$  = Dynamic component of active thrust force acting at a uniform distribution on wall (lb/ft)

$i$  = Slope of backfill (degrees)\*\*

$S_A$  = Active (static) component of equivalent fluid pressure (lb/ft<sup>3</sup>)\*

$S_{tE}$  = Active earth pressure (dynamic) at the top of the wall (lb/ft<sup>3</sup>)

$S_{bA}$  = Active earth pressure (static) at the bottom of the wall (lb/ft<sup>3</sup>)

$\phi$  = Internal angle of friction for backfill (degrees)\*\*

$\delta$  = Angle from normal of back of wall (degrees). Based on friction developing between wall and backfill\*\*

$\beta$  = Slope of back of wall (degrees)\*\*

$S_{AE}$  = Dynamic component of equivalent fluid pressure (lb/ft<sup>3</sup>)\*

$S_{bE}$  = Active earth pressure (dynamic) at bottom of the wall (lb/ft<sup>3</sup>)\*

\*Refer to report text for calculated values \*\*Refer to report text for modeled/assumed values

Notes

1. Uniform pressure distribution of seismic loading is based on empirical evaluations [Sherif et al, 1982 and Whitman, 1990].
2. Placement of seismic resultant force at 0.6H is based on wall behavior and model test results [Whitman, 1990].



# Carlson Geotechnical

A division of Carlson Testing, Inc.  
Phone: (503) 601-8250  
Fax: (503) 601-8254

Bend Office (541) 330-9155  
Eugene Office (541) 345-0289  
Salem Office (503) 589-1252  
Tigard Office (503) 684-3460



## Appendix A: Results of Infiltration Testing

**Sunset Primary School  
2351 Oxford Street  
West Linn, Oregon**

CGT Project No. G1504201

July 15, 2015

*Prepared For:*

West Linn Wilsonville School District 3JT  
Attn: Mr. Remo Douglas  
2755 SW Borland Road  
Tualatin, Oregon 97062

*Prepared By:*

**CARLSON GEOTECHNICAL**

**A.1.0 CORRESPONDENCE WITH CIVIL ENGINEER**

The project civil engineer (Mr. Mark Wharry, P.E. of KPFF) requested infiltration testing at seven locations on a site map provided to CGT. Limited access near the southwest corner of the existing school building precluded infiltration testing at one of the requested locations and thus, CGT conducted infiltration testing at six locations across the site. The approximate locations of the infiltration tests (designated as IT-1 through IT-6) are shown on the Site Plan, which is attached to the report as Figure 2.

**A.2.0 TEST PROCEDURE**

Six infiltration tests were performed within five prepared test pits and one machine-drilled boring on June 18 and June 22, 2015, in general accordance with the Encased Falling Head Test method described in Appendix F.2 of the City of Portland Stormwater Management Manual (January 2014). The following table presents the depth of the tests and the subsurface material encountered at the test depths.

**Table A1: Infiltration Test Depths & Materials**

Infiltration Test	Exploration	Test Depth <sup>1</sup> (feet bgs)	Test Elevation <sup>2</sup> (feet)	Subsurface Material at Test Depth
IT-1	B-5	4	551	Lean Clay (CL)
IT-2	TP-7	5	550	Lean Clay (CL)
IT-3	TP-8	3½	543½	Lean Clay (CL)
IT-4	TP-9	5¼	553¾	Lean Clay with Gravel (CL)
IT-5	TP-10	5½	548½	Lean Clay (CL)
IT-6	TP-6	5½	542½	Lean Clay (CL)

<sup>1</sup> Relative to existing site grades. bgs = below ground surface.

<sup>2</sup> Determined from elevation contour utility provided by MetroMaps.com. Elevations should be considered approximate.

The machine-drilled boring (B-5) was advanced to the test depth using a limited access track-mounted drill rig with an 8-inch diameter hollow-stem auger. The test pits (TP-6 through TP-10) were excavated using a Case CX-55B mini-excavator with a 24-inch wide toothed bucket. A 6-inch-inner-diameter PVC pipe was inserted into each of the prepared test pits or machine-drilled boring and hydraulically-pushed with the excavator or drill rig about 6 inches into the exposed soil at the infiltration test depth. The lower 2 inches of the test pipes was filled with open-graded gravel fill up to about ¾-inch in diameter to prevent scouring. The subsurface soils at the base of the pipes were “soaked” for four hours in accordance with the referenced test method by pouring about 12 inches of water (measured vertically) into the test pipes. After the 4-hour soaking period, testing was initiated by recording the drop in water level of an approximate 6-inch column of water on 10- to 20-minute intervals. A minimum of three trials were administered at each infiltration test location.

**A.3.0 TEST RESULTS**

The following tables present the raw data and calculated rates of infiltration that we observed from the infiltration tests. Please note the calculated infiltration rates do not include any safety or correction factors.

**Table A2: Results of Infiltration Test IT-1**

Infiltration Test	Trial	Time Interval (minutes)	Drop in Water Level <sup>1</sup> (inches)	Raw Infiltration Rate (inches per hour)
IT-1	1	20	1	3
	2	20	1	3
	3	20	1	3

<sup>1</sup> Measured to nearest 1/8- inch using a measuring tape and top of pipe as a fixed datum.

**Table A3: Results of Infiltration Test IT-2**

Infiltration Test	Trial	Time Interval (minutes)	Drop in Water Level <sup>1</sup> (inches)	Raw Infiltration Rate (inches per hour)
IT-2	1	10	¼	1½
	2	10	¼	1½
	3	10	¼	1½

<sup>1</sup> Measured to nearest 1/8- inch using a measuring tape and top of pipe as a fixed datum.

**Table A4: Results of Infiltration Test IT-3**

Infiltration Test	Trial	Time Interval (minutes)	Drop in Water Level <sup>1</sup> (inches)	Raw Infiltration Rate (inches per hour)
IT-3	1	10	2¼	13½
	2	10	17/8	11¼
	3	20	17/8	11¼

<sup>1</sup> Measured to nearest 1/8- inch using a measuring tape and top of pipe as a fixed datum.

**Table A5: Results of Infiltration Test IT-4**

Infiltration Test	Trial	Time Interval (minutes)	Drop in Water Level <sup>1</sup> (inches)	Raw Infiltration Rate (inches per hour)
IT-4	1	20	0	0
	2	20	0	0
	3	20	0	0

<sup>1</sup> Measured to nearest 1/8- inch using a measuring tape and top of pipe as a fixed datum.

**Table A6: Results of Infiltration Test IT-5**

Infiltration Test	Trial	Time Interval (minutes)	Drop in Water Level <sup>1</sup> (inches)	Raw Infiltration Rate (inches per hour)
IT-5	1	10	½	3
	2	10	½	3
	3	10	½	3

<sup>1</sup> Measured to nearest 1/8- inch using a measuring tape and top of pipe as a fixed datum.

**Table A7: Results of Infiltration Test IT-6**

Infiltration Test	Trial	Time Interval (minutes)	Drop in Water Level <sup>1</sup> (inches)	Raw Infiltration Rate (inches per hour)
IT-6	1	10	2¼	13½
	2	10	2¼	13½
	3	10	2⅛	12¾
	4	10	2⅛	12¾

<sup>1</sup> Measured to nearest 1/8- inch using a measuring tape and top of pipe as a fixed datum.

#### **A.4.0 DISCUSSION**

As indicated in the preceding section, we calculated raw infiltration rates ranging from 0 to about 12¾ inches per hour. These infiltration rates do not include any safety or correction factors. We recommend the stormwater infiltration system designer consult the appropriate design manual in order to assign appropriate safety/correction factors to calculate the design infiltration rate for the infiltration system. Because stormwater infiltration facility locations have not been determined yet, the infiltration data presented in this report should be considered preliminary. We understand additional infiltration testing may be required once the civil engineer has a more refined knowledge of where stormwater infiltration facilities will be located.

# Carlson Geotechnical

A Division of Carlson Testing, Inc.

Phone: (503) 601-8250

Fax: (503) 601-8254

Bend Office (541) 330-9155  
Eugene Office (541) 345-0289  
Salem Office (503) 589-1252  
Tigard Office (503) 684-3460



## Appendix B: Site-Specific Seismic Hazards Study

**Sunset Primary School  
2351 Oxford Street  
West Linn, OR**

CGT Project Number G1504201

July 15, 2015

*Prepared for:*

West Linn Wilsonville School District 3JT  
Attn: Mr. Remo Douglas  
2755 SW Borland Road  
Tualatin, Oregon 97062

*Prepared by:*

**CARLSON GEOTECHNICAL**

## TABLE OF CONTENTS

<b>B.1.0</b>	<b>INTRODUCTION</b> .....	<b>3</b>
<b>B.2.0</b>	<b>GROUND MOTION HAZARD ANALYSIS</b> .....	<b>3</b>
<b>B.2.1</b>	<b>Earthquake Sources and Seismicity</b> .....	<b>3</b>
B.2.1.1	Crustal Sources .....	4
B.2.1.2	Cascadia Subduction Zone Seismic Sources .....	7
B.2.1.3	Characteristic Earthquake Magnitude .....	8
B.2.1.4	Seismic Sources in the Vicinity of the Site .....	11
<b>B.3.0</b>	<b>SEISMIC SITE CLASS</b> .....	<b>13</b>
<b>B.3.1</b>	<b>Site Profile to Bedrock</b> .....	<b>13</b>
<b>B.3.2</b>	<b>Site Class Determination</b> .....	<b>13</b>
<b>B.4.0</b>	<b>SEISMIC DESIGN</b> .....	<b>14</b>
<b>B.4.1</b>	<b>Seismic Ground Motion Values</b> .....	<b>14</b>
<b>B.5.0</b>	<b>SEISMIC HAZARDS</b> .....	<b>15</b>
<b>B.5.1</b>	<b>Liquefaction</b> .....	<b>15</b>
B.5.1.1	Overview .....	15
<b>B.5.2</b>	<b>Slope Stability</b> .....	<b>16</b>
<b>B.5.3</b>	<b>Surface Rupture</b> .....	<b>16</b>
B.5.3.1	Faulting.....	16
B.5.3.2	Lateral Spread.....	16
<b>B.5.4</b>	<b>Tsunami/Seiche Inundation</b> .....	<b>16</b>
<b>B.6.0</b>	<b>REPORT SUBMITTAL</b> .....	<b>17</b>

## ATTACHMENTS

Cascadia Subduction Zone .....	Figure B1
--------------------------------	-----------

Doc ID: G:\GEOTECH\PROJECTS\2015 Projects\New Sunset Primary School\008 - Deliverables\Report Files\Appendix B - SSSH.S.docx

## **B.1.0 INTRODUCTION**

Based on the information provided, we understand the proposed building will be classified as a “Special Occupancy Structure” per Oregon Revised Statutes (ORS) 455.447. Accordingly, the building will be assigned as Risk Category III per Table 1604.5 of the 2014 Oregon Structural Specialty Code (OSSC). A Site-Specific Seismic Hazards Study (SSSHS) is required for the project in accordance with Section 1803.3.2 of the 2014 OSSC. This appendix presents the results of that study.

## **B.2.0 GROUND MOTION HAZARD ANALYSIS**

The geological and geotechnical data developed within the geotechnical report were used to evaluate the ground motion response of the project site to various earthquake sources and events. The ground motion hazard analysis addresses the following seismic hazards for the site in accordance with Section 1803.7 of the OSSC:

- Ground Shaking;
- Liquefaction;
- Lateral Spread;
- Earthquake-induced Landsliding;
- Inundation from Tsunami / Seiche; and
- Surface Rupture due to Fault Displacement.

The analysis was based on procedures presented in Section 1613.3.4 of the 2014 OSSC and Section 11.4 of American Society of Civil Engineers (ASCE) Minimum Design Loads for Buildings and Other Structures (ASCE 7-10).

### **B.2.1 Earthquake Sources and Seismicity**

The site is located in a tectonically active area that may be affected by crustal earthquakes, intra-slab earthquakes, or large subduction zone earthquakes. Damaging crustal earthquakes in this region may be derived from local sources such as the Helvetia fault, Beaverton fault zone, Canby-Molalla fault, Newberg fault, Gales Creek fault zone, Mount Angel fault, Bolton fault, Oatfield fault, East Bank fault, Portland Hills fault, Grant Butte fault, Damascus-Tickle Creek fault, Lacamas Lake fault, and the Sandy River fault zone<sup>1</sup>. Crustal earthquakes typically occur at depths ranging from 15 to 40 kilometers bgs<sup>2</sup>. Intra-slab earthquakes occur within the subducting Juan De Fuca Plate at depths ranging from approximately 30 to 60 kilometers bgs. Large subduction zone earthquakes in this region are derived from the Cascadia Subduction Zone (CSZ). Due to the lack of historical data on large subduction zone earthquakes, a typical depth for the occurrence of a subduction zone earthquake was inferred from models presented by Geomatrix Consultants in 1995<sup>3</sup>, and is roughly 10 to 25 kilometers bgs.

---

<sup>1</sup> U.S. Geologic Survey, 2015. Quaternary Fault and Fold Database, <http://earthquake.usgs.gov/qaft/>

<sup>2</sup> Geomatrix Consultants, 1995. Seismic Design Mapping, State of Oregon: unpublished report prepared for Oregon Department of Transportation, Personal Services Contract 11688, January 1995.

<sup>3</sup> Geomatrix Consultants, 1995. *Ibid.*



### B.2.1.1 Crustal Sources

The following mapped faults are considered active or potentially active and are located within about 50 kilometers of the site<sup>4</sup>. Refer to Table B3 presented in Section B.2.1.4 of this appendix for the approximate distance and direction to these faults from the project site.

#### B.2.1.1.1 Helvetia fault (USGS 714)

The Helvetia fault is a north-northwest trending structure located on the northeastern margin of the Tualatin Basin<sup>5</sup>. There is no evidence for displacement of late Quaternary deposits along the fault; however, the most recent age of displacement is poorly constrained<sup>6</sup>. Therefore, the fault is considered active, but with a long recurrence interval.

#### B.2.1.1.2 Beaverton fault zone (USGS 715)

The Beaverton fault zone<sup>7</sup> consists of an east-west striking normal fault that forms the southern margin of the Tualatin basin. This fault offsets Miocene Columbia River Basalt, but is covered by thick sequences of Pliocene to Pleistocene Missoula flood deposits. As a result, no fault scarp is present at the surface, and the Beaverton fault zone is not present on most geologic maps of the area. Yeats and others<sup>8</sup> indicate that the Beaverton Faults displace post-Columbia River Basalt sediments; however, the age and nature of deformation is not known. The Beaverton fault is considered active, but with a long recurrence interval.

#### B.2.1.1.3 Canby-Molalla fault (USGS 716)

The Canby-Molalla fault is a right-lateral strike-slip fault located within the Willamette Valley<sup>9</sup>. The Canby-Molalla fault appears to offset Missoula flood deposits, and seismic reflection surveys suggest Holocene deformation of sediments. The fault has little geomorphologic expression, but is considered active, with a slip rate of less than 0.2 mm per year.

#### B.2.1.1.4 Newberg fault (USGS 717)

The Newberg fault is a 5-kilometer-long portion of the Gales Creek-Mount Angel structural zone, which consists of a 73-kilometer-long zone of right-lateral strike-slip faults located within the Willamette Valley<sup>10</sup>. The fault zone offsets Miocene Columbia River basalts, but no unequivocal evidence for Quaternary displacement has been identified. The Newberg fault is recognized in the subsurface by vertical separation of the Columbia River Basalt, and offset seismic reflectors in overlying basin sediments<sup>11,12</sup>, with no definitive geomorphic evidence of faulting. The majority of the fault trace is covered with Holocene alluvium, which may have buried recent deformation. Due to the uncertainty in activity level, the fault has been classified as active.

---

<sup>4</sup> U.S. Geologic Survey, 2015. Quaternary Fault and Fold Database, <http://earthquake.usgs.gov/qfaults/>

<sup>5</sup> Personius, S.F., compiler, 2002. Fault number 714, Helvetia fault, in Quaternary fault and fold database of the United States: U.S. Geological Survey website, <http://earthquakes.usgs.gov/hazards/qfaults>.

<sup>6</sup> Geomatrix Consultants, 1995. *Ibid.*

<sup>7</sup> Personius, S.F., compiler, 2002. Fault number 715, Beaverton fault zone, in Quaternary fault and fold database of the United States: U.S. Geological Survey website, <http://earthquakes.usgs.gov/hazards/qfaults>.

<sup>8</sup> Yeats, R.S., Graven, E.P., Werner, K.S., Goldfinger, C., and Popowski, T., 1996. *Ibid.*

<sup>9</sup> Personius, S.F., compiler, 2002. Fault number 716, Canby-Molalla fault, in Quaternary fault and fold database of the United States: U.S. Geological Survey website, <http://earthquakes.usgs.gov/hazards/qfaults>.

<sup>10</sup> Personius, S.F., compiler, 2002. Fault number 717, Newberg fault, in Quaternary fault and fold database of the United States: U.S. Geological Survey website, <http://earthquakes.usgs.gov/hazards/qfaults>.

<sup>11</sup> Werner, K.S., Nabelek, J., Yeats, R.S., Malone, S., 1992. The Mount Angel fault: implications of seismic-reflection data and the Woodburn, Oregon, earthquake sequence of August, 1990: Oregon Geology, v. 54, p. 112-117.

<sup>12</sup> Yeats, R.S., Graven, E.P., Werner, K.S., Goldfinger, C., and Popowski, T., 1996. *Ibid.*

**B.2.1.1.5 Gales Creek fault zone (USGS 718)**

The Gales Creek fault zone is a 73-kilometer-long zone of northwest-trending right-lateral strike-slip faults located on the western margin of the Willamette Valley<sup>13</sup>. The fault zone offsets Miocene Columbia River basalts, but no unequivocal evidence for Quaternary displacement has been identified. However, the majority of the faults are covered with very recent alluvium, which may have buried evidence of recent deformation. Estimates for the latest movements along the Gales Creek fault zone typically predate the late Pleistocene; in other words, the fault has not had activity within the last approximately 30,000 years. The recurrence interval for the Gales Creek fault zone is likely greater than 50,000 years, based on the information available.

**B.2.1.1.6 Mount Angel fault (USGS 873)**

The Mount Angel fault is a northwest-trending, steeply northeast-dipping, oblique-slip reverse fault with a length of about 30 kilometers<sup>14</sup>. The fault is mapped in the subsurface based on geophysical data, water well logs, and historical seismicity<sup>15,16</sup>. It displaces Columbia River Basalt at depth, as well as younger, overlying sediments<sup>17</sup>. Surface indications of the fault are minimal. The Mount Angel fault is considered to be the source for a series of small earthquakes (<M3.5) that occurred in 1990 near the town of Woodburn, and a M5.6 earthquake that occurred in 1993 near the town of Scotts Mills<sup>18,19</sup>.

**B.2.1.1.7 Bolton fault (USGS 874)**

The Bolton fault is a northwest-trending reverse fault, with a length of about 9 kilometers in the subsurface<sup>20</sup>. There is no evidence that the Bolton fault has been active since the late Pleistocene; however, the fault is classified as potentially active because of the limited exposures and uncertainties in the relationships between local scarps and late Pleistocene Missoula flood deposits<sup>21</sup>. On this basis, a long recurrence interval is assigned to the Bolton Fault.

**B.2.1.1.8 Oatfield fault (USGS 875)**

The Oatfield fault consists of a 29-kilometer-long steeply dipping reverse fault that forms escarpments in Miocene Columbia River Basalt in the Tualatin Mountains<sup>22</sup>. No fault scarps or displacement of surficial deposits have been described, but exposures within tunnels show offset of Boring Lava, indicating Quaternary activity. The slip rate for the Oatfield fault has been calculated to be about 0.1 mm per year based on the tunnel exposures. Given the very low slip rate and lack of displacement of surficial deposits, this fault is considered to have a very long recurrence interval.

---

<sup>13</sup> Personius, S.F., compiler, 2002. Fault number 718, Gales Creek fault zone, in Quaternary fault and fold database of the United States: U.S. Geological Survey website, <http://earthquakes.usgs.gov/hazards/qfaults>.

<sup>14</sup> Personius, S.F., compiler, 2002. Fault number 873, Mount Angel fault, in Quaternary fault and fold database of the United States: U.S. Geological Survey website, <http://earthquakes.usgs.gov/hazards/qfaults>.

<sup>15</sup> Yeats, R., *et al.*, 1991. Tectonics of the Willamette Valley, Oregon. U.S. Geological Survey Open File Report 91-441-P, 47 p.

<sup>16</sup> Werner, K.S., *et al.*, 1992. The Mount Angel Fault: Implications of Seismic-Refraction Data and the Woodburn, Oregon, Earthquake Sequence of August, 1990. Oregon Geology, v. 54, p. 112-117.

<sup>17</sup> Unruh, J.R., *et al.*, 1994. Seismotectonic Evaluation: Scoggins Dam, Tualatin Project, Northwestern Oregon: Final Report, prepared by William Lettiss and Associates and Woodward Clyde Federal Services, Oakland, California for the U.S. Bureau of Reclamation, Denver, Colorado.

<sup>18</sup> Geomatrix Consultants, 1995. *Ibid.*

<sup>19</sup> Werner, K.S., *et al.*, 1992. *Ibid.*

<sup>20</sup> Personius, S.F., compiler, 2002. Fault number 874, Bolton fault, in Quaternary fault and fold database of the United States: U.S. Geological Survey website, <http://earthquakes.usgs.gov/hazards/qfaults>.

<sup>21</sup> Geomatrix Consultants, 1995. *Ibid.*

<sup>22</sup> Personius, S.F., compiler, 2002. Fault number 875, Oatfield fault, in Quaternary fault and fold database of the United States: U.S. Geological Survey website, <http://earthquakes.usgs.gov/hazards/qfaults>.

**B.2.1.1.9 East Bank fault (USGS 876)**

The East Bank fault<sup>23</sup> consists of a 29-kilometer-long steeply dipping reverse fault that parallels the Portland Hills fault. No Quaternary surficial fault scarps have been identified, and the fault is largely buried by thick sequences of Pleistocene Missoula flood deposits. Recent shallow seismic reflection data suggest subsurface displacement of the older Missoula flood deposits.

**B.2.1.1.10 Portland Hills fault (USGS 877)**

The Portland Hills fault zone<sup>24</sup> is a series of northwest-trending faults forming the northeastern margin of the Tualatin Mountains. The faults associated with this structural zone vertically displace the Columbia River Basalt Group by 1,130 feet, and appear to control thickness changes in late Pleistocene sediment<sup>25</sup>. Geomorphic lineaments suggestive of Pleistocene deformation have been identified within the fault zone, but none of the fault segments has been shown to cut Holocene deposits<sup>26,27</sup>. The fact that the faults do not cut Holocene sediments is most likely a result of the faulting being related to a time of intense uplift of the Oregon Coast Range during the Miocene, and little to no movement along the faults during the Holocene.

Recent studies of this fault<sup>28</sup> concluded that the Portland Hills fault is active, based on contemporary seismicity in the vicinity of the fault, and seismic reflection data suggesting that the fault cuts late Pleistocene layered strata. Additionally, in May of 2000, while taking magnetic readings to map the fault, an Oregon Department of Geology and Mineral Industries (DOGAMI) geologist observed folded sediment in a retaining wall cut in North Clackamas Park south of Portland. The folded sediments consisted of sand and silt deposited by Pleistocene floods derived from glacial Lake Missoula approximately 12,800 to 15,000 years ago. An investigation of the folded strata by DOGAMI geologists and engineering consultants showed that the entire sequence of sediment layers is folded and they concluded that this folding is evidence for an active fault beneath the site, and the fault is either the Portland Hills fault, or a closely related structure<sup>29</sup>.

**B.2.1.1.11 Grant Butte fault (USGS 878)**

The Grant Butte fault<sup>30</sup> forms the southern margin of the Portland basin, and consists of a 10-kilometer-long normal fault. The Grant Butte fault offsets Pliocene-Pleistocene Springwater Formation and Boring Lava. No Quaternary surficial fault scarps have been identified, but the fault is largely buried by thick sequences of Pliocene to Pleistocene Missoula flood deposits. Based on radiometric age dating techniques, the fault

---

<sup>23</sup> Personius, S.F., compiler, 2002. Fault number 876, East Bank fault, in Quaternary fault and fold database of the United States: U.S. Geological Survey website, <http://earthquakes.usgs.gov/hazards/qfaults>.

<sup>24</sup> Personius, S.F., compiler, 2002. Fault number 877, Portland Hills fault, in Quaternary fault and fold database of the United States: U.S. Geological Survey website, <http://earthquakes.usgs.gov/hazards/qfaults>.

<sup>25</sup> Mabey, M.A., Madin, I.P., Youd, T.L., Jones, C.F., 1993, Earthquake hazard maps of the Portland quadrangle, Multnomah and Washington Counties, Oregon, and Clark County, Washington: Oregon Department of Geology and Mineral Industries Geological Map Series GMS-79, Plate 2, 1:24,000.

<sup>26</sup> Conforth and Geomatrix Consultants, 1992. Seismic hazard evaluation, Bull Run dam sites near Sandy, Oregon: unpublished report to City of Portland Bureau of Water Works.

<sup>27</sup> Balsillie, J.J. and Benson, G.T., 1971. Evidence for the Portland Hills fault: The Ore Bin, Oregon Dept. of Geology and Mineral Industries, v. 33, p. 109-118.

<sup>28</sup> Wong *et al.*, 2001. The Portland Hills Fault: An Earthquake Generator or Just Another Old Fault? Published by Oregon Geology, V63, number 2, Spring 2001.

<sup>29</sup> Madin and Hemphill-Haley, 2001: The Portland Hills Fault at Rowe Middle School. Oregon Geology V63 p47.

<sup>30</sup> Personius, S.F., compiler, 2002. Fault number 878, Grant Butte fault, in Quaternary fault and fold database of the United States: U.S. Geological Survey website, <http://earthquakes.usgs.gov/hazards/qfaults>.

has been active within the late Quaternary. Therefore, the Grant Butte fault is considered active with a long recurrence interval.

#### B.2.1.1.12 Damascus-Tickle Creek fault zone (USGS 879)

The Damascus-Tickle Creek fault zone consists of numerous relatively short northeast and northwest trending forming a broad fault zone along the southern edge of the Portland basin<sup>31</sup>. The location of several eruptive vents of the Boring Lava suggest a direct relationship with the Damascus-Tickle Creek fault zone. The majority of the faults within the zone are buried by Pliocene to Pleistocene Missoula flood deposits, however, at least one fault strand may offset the flood deposits.

#### B.2.1.1.13 Lacamas Lake fault (USGS 880).

The Lacamas Lake fault<sup>32</sup> is a northwest-trending structure located in the vicinity of Lacamas Lake, near Camas, Washington, at the northeastern margin of the Portland basin. This fault was originally identified by well-expressed lineaments defined by the relatively steep linear valley margins along both sides of Lacamas Lake<sup>33</sup>. Although recent activity on the Lacamas Lake fault is uncertain, the fault is considered active based on possible displacement of Troutdale sediments, prominent topographic lineaments associated with the fault, and possible associated seismicity. The fault is buried by Pleistocene Missoula flood deposits, suggesting a long recurrence interval.

#### B.2.1.2 Cascadia Subduction Zone Seismic Sources

The Cascadia Subduction Zone (CSZ) is a 1,000-kilometer-long zone of active tectonic convergence where oceanic crust of the Juan De Fuca Plate is subducting beneath the North American continental plate at a rate of about 3 to 4 centimeters per year<sup>34</sup>. The fault trace is located off of the Oregon Coast, approximately 215 kilometers west of the site. Two primary sources of seismicity are associated with the CSZ: the interface between the two plates, and faulting within the subducting plate. These sources are detailed below. The location of the CSZ and associated sources of seismicity are shown on the attached Figure B1.

##### B.2.1.2.1 Plate Interface Source

Very little seismicity has occurred on the plate interface in historic time, and as a result, the seismic potential of the CSZ is a subject of scientific controversy. The lack of seismicity may be interpreted as a period of quiescent stress buildup between large magnitude earthquakes, or characteristic of the long-term behavior of the subduction zone. A growing body of geologic evidence; however, strongly suggests that large prehistoric subduction zone earthquakes have occurred<sup>35,36,37,38</sup>. This evidence includes:

---

<sup>31</sup> Personius, S.F., compiler, 2002. Fault number 879, Damascus-Tickle Creek fault zone, in Quaternary fault and fold database of the United States: U.S. Geological Survey website, <http://earthquakes.usgs.gov/hazards/qfaults>.

<sup>32</sup> Personius, S.F., compiler, 2002. Fault number 880, Lacamas Lake fault, in Quaternary fault and fold database of the United States: U.S. Geological Survey website, <http://earthquakes.usgs.gov/hazards/qfaults>.

<sup>33</sup> Madin and Hemphill-Haley, 2001: The Portland Hills Fault at Rowe Middle School. Oregon Geology V63 p47.

<sup>34</sup> DeMets, C., Gordon, R.G., Argus, D.F., Stein, S., 1990. Current plate motions: Geophysical Journal International, v. 101, p. 425-478.

<sup>35</sup> Geomatrix Consultants, 1995. *Ibid*.

<sup>36</sup> Atwater, B.F., 1992. Geologic evidence for earthquakes during the past 2,000 years along the Copalis River, southern coastal Washington: Journal of Geophysical Research, v. 97, p. 1901-1919.

<sup>37</sup> Carver, G., 1992. Late Cenozoic tectonics of coastal northern California: American Association of Petroleum Geologists-SEPM Field Trip Guidebook, May, 1992.

<sup>38</sup> Peterson, C.D., Darioenzo, M.E., Burns, S.F., and Burris, W.K., 1993. Field trip guide to Cascadia paleoseismic evidence along the northern California coast: evidence of subduction zone seismicity in the central Cascadia margin: Oregon Geology, v. 55, p. 99-144.

(1) buried tidal marshes recording episodic, sudden subsidence along the coast of northern California, Oregon, and Washington; (2) burial of subsided tidal marshes by tsunami wave deposits; (3) paleoliquefaction features; and (4) geodetic uplift patterns on the Oregon Coast. Radiocarbon dates on buried tidal marshes indicate a recurrence interval for major subduction zone earthquakes of 250 to 650 years, with the last major event occurring 300 years ago<sup>39,40,41,42,43</sup>. The inferred seismogenic portion of the plate interface is roughly 10 to 25 kilometers deep, spanning a 75-kilometer wide area roughly centered on the Oregon coastline. The eastern margin of the plate interface seismogenic zone is approximately 110 kilometers west of the site.

#### B.2.1.2.2 Intra-Slab Source

The subducting Juan De Fuca (oceanic) Plate dips at an angle of 10 to 20 degrees as it descends beneath the North American plate. The curvature of the subducted plate increases as the advancing edge moves east, creating extensional forces within the plate. Normal faulting occurs in response to these extensional forces. This region of maximum curvature and faulting of the slab is where large intra-slab earthquakes are expected to occur, and is located at depths ranging from 30 to 60 kilometers<sup>44</sup>. The site is located on the eastern margin of the intra-slab seismogenic zone<sup>45</sup> (see attached Figure B1). Historically, the seismicity rate within the Juan De Fuca Plate beneath Oregon is very low in northern Oregon and southwest Washington, and extremely low along the southern and central Oregon coast<sup>46,47,48</sup>.

#### B.2.1.3 Characteristic Earthquake Magnitude

The maximum characteristic earthquake magnitude is defined as the largest earthquake that could be expected to be generated by a specific seismic source, independent of recurrence interval. CGT determined the magnitude of characteristic earthquakes from a review of historical earthquake records and empirical relationships.

##### B.2.1.3.1 Historical Earthquakes

Magnitude estimates for the characteristic earthquake are based largely on the record of historical earthquakes in the region of interest. Table B1 lists earthquakes with magnitudes larger than M4.9 that have occurred within 300 kilometers of the site since 1873<sup>49</sup>. These earthquakes are also shown on Inset 1: Historical Earthquakes.

---

<sup>39</sup> Geomatrix Consultants, 1995. *Ibid.*

<sup>40</sup> Atwater, B.F., 1992. *Ibid*

<sup>41</sup> Carver, G., 1992. *Ibid*

<sup>42</sup> Peterson, C.D., Darioenzo, M.E., Burns, S.F., and Burris, W.K., 1993. *Ibid.*

<sup>43</sup> Personius, S.F., and Nelson, A.R., compilers, 2005. Fault number 781, in Quaternary fault and fold database of the United States: U.S. Geological Survey website, <http://earthquakes.usgs.gov/regional/qfaults>.

<sup>44</sup> Geomatrix Consultants, 1995. *Ibid.*

<sup>45</sup> McCrory, Blair, Oppenheimer, and Walter, 2004. Depth to the Juan de Fuca slab beneath the Cascadia subduction margin – A 3-D model for storing earthquakes: U.S. Geological Survey Data Series 91.

<sup>46</sup> Geomatrix Consultants, 1995. *Ibid.*

<sup>47</sup> Geomatrix Consultants, 1993. Seismic margin Earthquake For the Trojan Site: Final Unpublished Report For Portland General Electric Trojan Nuclear Plant, Rainier, Oregon, May 1993.

<sup>48</sup> Personius, S.F., and Nelson, A.R., compilers, 2005. Fault number 781, in Quaternary fault and fold database of the United States: U.S. Geological Survey website, <http://earthquakes.usgs.gov/regional/qfaults>.

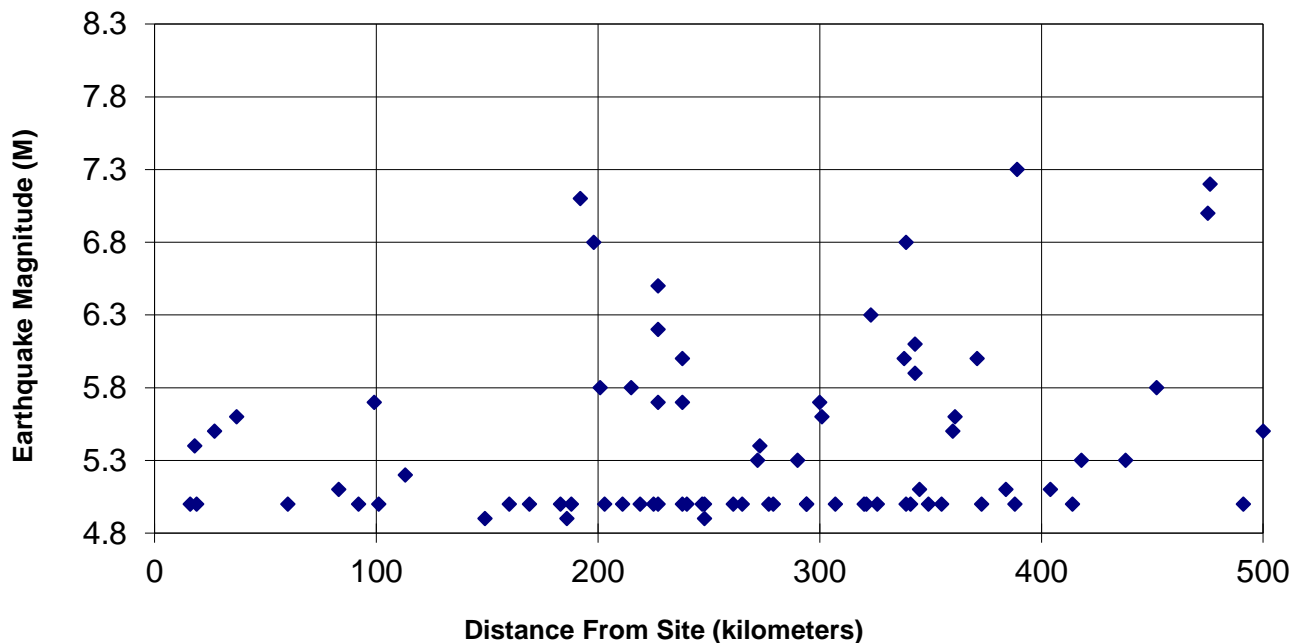
<sup>49</sup> Wong et al, 2000. Wong, I. Silva, W. Bott, J., Wright, D., Thomas, P., Gregor, N., Li, S., Mabey, M., Sojourner, A., Wang, Y. IMS-15. Earthquake Scenario and Probabilistic Ground Shaking Maps for the Portland, Oregon, Metropolitan area. Portland Hills Fault M6.8 Earthquake, Peak Horizontal Acceleration at the Ground Surface.

**Table B1 Historical Earthquakes since 1873 within 250 kilometers of the site with Magnitudes Greater than M4.9**

Date	Magnitude	Distance from Site	Location
December 16, 1953	M5.0	16 km	7 km WSW of Portland, OR
October 12, 1877	M5.4*	18 km	10 km ESE of Portland, OR
December 29, 1941	M5.0	19 km	1 km S of Portland, OR
November 06, 1962	M5.5	27 km	8 km NNE of Portland, OR
March 25, 1993	M5.6	37 km	23 km ESE of Woodburn, OR (Scotts Mills)
July 19, 1930	M5.0	60 km	15 km WNW of Salem, OR
September 17, 1961	M5.1	83 km	20 km SSE of Mt St Helens, WA
November 17, 1957	M5.0	92 km	18 km S of Tillamook, OR
May 18, 1980	M5.7	99 km	1 km NNE of Mt St Helens, WA
March - May, 1980	M4.9 - M5.2	101 km	27 events at Mt St Helens, WA
February 14, 1981	M5.2	113 km	2 km N of Elk Lake, WA
December 24, 1989	M4.9	149 km	16 km NE of Morton, WA
May 28, 1981	M5.0	160 km	4 km ENE of Goat Rocks, WA
February 15, 1946	M5.0	169 km	1 km NW of Eatonville, WA
October 07, 1958	M5.0	183 km	34 km SSW of Aberdeen, WA
July 12, 2004	M4.9	186 km	48 km SW of Newport, OR
February 23, 1946	M5.0	188 km	1 km SE of Olympia, WA
April 13, 1949	M7.1	192 km	12 km ENE of Olympia, WA
February 28, 2001	M6.8	198 km	17 km NE of Olympia, WA (Nisqually)
July 03, 1999	M5.8	201 km	8 km N of Satsop, WA
December 07, 1944	M5.0	203 km	6 km W of Aberdeen, WA
June 10, 2001	M5.0	211 km	18 km N of Satsop, WA
February 15, 1946	M5.8	215 km	28 km N of Olympia, WA
November 08, 1960	M5.0	219 km	115 km WNW of Newport, OR
January 29, 1995	M5.0	225 km	18 km NNE of Tacoma, WA
May 15, 1954	M5.0	227 km	19 km NNW of Tacoma, WA
April 30, 1882	M5.7*	227 km	19 km S of Bremerton, WA
November 13, 1939	M6.2	227 km	19 km S of Bremerton, WA
April 29, 1965	M6.5	227 km	18 km N of Tacoma, WA
April 30, 1945	M5.0	238 km	13 km SSE of North Bend, WA
April 29, 1945	M5.7	238 km	13 km SSE of North Bend, WA
December 12, 1880	M6.0*	238 km	12 km SE of Bremerton, WA
December 31, 1931	M5.0	240 km	29 km WSW of Bremerton, WA
March 07, 1891	M5.0*	247 km	3 km E of North Bend, WA
June 23, 1997	M4.9	248 km	6 km NE of Bremerton, WA
February 11, 1957	M5.0	248 km	6 km E of North Bend, WA

\* estimated from historical accounts.

**Inset 1. Historical Earthquakes**



Based on the historical record and crustal faulting models of the region, the maximum earthquake for crustal sources within the Pacific Northwest is estimated to be M5.75<sup>50</sup> (independent of recurrence interval). Similarly, the maximum earthquake for an intra-slab source on the subducting Juan De Fuca plate is estimated to be M7.5 to M7.7.

**B.2.1.3.2 Empirical Determination of Characteristic Earthquake**

Another method for estimating the characteristic earthquake that a particular seismic source could generate is by using empirical relationships between earthquake magnitude and fault rupture length<sup>51</sup>. Based on these relationships, the size of historical earthquakes, and the thickness of seismogenic crust in the region, the maximum earthquake magnitude expected from crustal sources is M6.0 to M6.6<sup>52</sup>. Based on the likely thin nature of the Juan De Fuca Plate, and comparing the historic seismicity along the CSZ intra-slab area with other similar intra-slab regions, Geomatrix Consultants<sup>53</sup> estimated the maximum magnitude earthquake for intra-slab sources as M7.0 to M7.5. Similarly, based on magnitude versus rupture area relationships for subduction zone earthquakes worldwide, the maximum magnitude of a CSZ earthquake is estimated to be M8.0 to M9.0<sup>54</sup>. These magnitudes are also reflected in the probabilistic analyses used by U.S. Geological Survey.

<sup>50</sup> Geomatrix Consultants, 1995. *Ibid.*  
<sup>51</sup> Bonilla, M.G., R. K. Mark, and J.J. Lienkaemper, 1984, Statistical relations among earthquake magnitude, surface rupture length, and surface fault displacement: Bulletin of the Seismological Society of America, V. 74, p. 2379-2411.  
<sup>52</sup> Geomatrix Consultants, 1995. *Ibid.*  
<sup>53</sup> Geomatrix Consultants, 1995. *Ibid.*  
<sup>54</sup> Geomatrix Consultants, 1995. *Ibid.*

**B.2.1.3.3 Code Specified Design Earthquake**

Section 1803.3.2.1 of the 2014 Oregon Structural Specialty Code (OSSC) indicates specific minimum requirements for earthquake magnitudes to be used in seismic analyses, which are summarized in the following table:

**Table B2 OSSC Minimum Design Earthquake**

Seismic Source	<u>Minimum</u> Design Earthquake
Shallow Crustal Faults	6.0
Cascadia Subduction Zone - Intra-Slab	7.0
Cascadia Subduction Zone - Interface	8.5

**B.2.1.4 Seismic Sources in the Vicinity of the Site**

Table B3 shows the previously discussed faults (Section B.2.1.1), the characteristic earthquake magnitude for each, and the distance and direction of the fault from the site.



**Table B3 Fault, Characteristic Earthquake Magnitude, and Distance from Site.**

USGS Fault No.	Earthquake Source	Char Mag	Type of Fault	USGS Fault Class <sup>1</sup>	Fault Orientation (strike & dip)	Approximate Earthquake depth (km)	Fault Trace Distance (km) & Direction from Site	Notes
874	Bolton fault	6.19	Reverse	B	N53W 60N	15 to 40 km	0.75 km NE	2
875	Oatfield fault	6.00	Reverse	A	N41W 70S	15 to 40 km	4 km NE	3,4
877	Portland Hills fault	7.05	Reverse	A	N37W 70N	15 to 40 km	5.5 km NE	2
716	Canby-Molalla fault	6.00	Right Lateral Strike Slip	A	N34W 90 (vertical)	15 to 40 km	6 km WSW	3,4
879	Damascus-Tickle Creek fault	6.00	Right Lateral Strike Slip	A	N-S 90 (Vertical)	15 to 40 km	8.5 km ENE	3,4
876	East Bank fault	6.00	Reverse	A	N46W 70N	15 to 40 km	12 km NE	3,4
878	Grant Butte fault	6.21	Normal	A	N90E 60N	15 to 40 km	14 km NNE	2
715	Beaverton fault zone	6.00	Normal	A	N86E Unknown Dip	15 to 40 km	19 km NW	3,4
717 / OR3	Newberg fault	6.85	Right Lateral Strike Slip	A	N42W 90 (vertical)	15 to 40 km	27 km WSW	2
OR4	Sandy River fault zone	6.50	Strike-Slip	C	90.00	15 to 40 km	28 km NE	2
873	Mount Angel fault	6.80	Thrust	A	N43E 60 to 70 N	15 to 40 km	30 km SW	2
880	Lacamas Lake fault	6.67	Normal	A	N43W 75S	15 to 40 km	30 km NE	2
714	Helvetia fault	6.40	Normal	A	N26W SW	15 to 40 km	31 km NW	2
718 / OR1	Gales Creek fault zone	6.75	Right Lateral Strike Slip	A	N41W 90 (vertical)	15 to 40 km	41 km WNW	2
	Intra Slab	7.00	Normal	A	N30W 10 to 20 E	30 to 60 km	On eastern margin of seismogenic zone	3
784	Cascadia Subduction Zone	9.0 8.3	Mega-Thrust	A	N30W 10 to 20 E	10 to 25 km	110 km W (to east edge of seismogenic zone)	3,5

1 USGS Fault Classes from USGS Earthquake Hazards Program, 2008 National Seismic Hazard Maps  
 Class A: Fault with convincing evidence of Quaternary activity (ACTIVE)  
 Class B: Fault that requires further study in order to confidently define their potential as possible sources of earthquake-induced ground motion (POTENTIALLY ACTIVE)  
 Class C: Fault with insufficient evidence for Quaternary activity (LOW POTENTIAL FOR ACTIVITY)

2 Characteristic earthquake magnitude from USGS Earthquake Hazards Program, 2008 National Seismic Hazard Maps – Fault Parameters

3 Characteristic earthquake magnitude from USGS Quaternary Fault and Fold Database of the United States

4 Characteristic earthquake magnitude from Section 1803.3.2.1 of the 2014 OSSC - Design Earthquake.

5 Models of earthquake magnitude assign variable magnitudes for different portions of the Cascadia Subduction Zone, so multiple magnitudes are provided.

### B.3.0 SEISMIC SITE CLASS

#### B.3.1 Site Profile to Bedrock

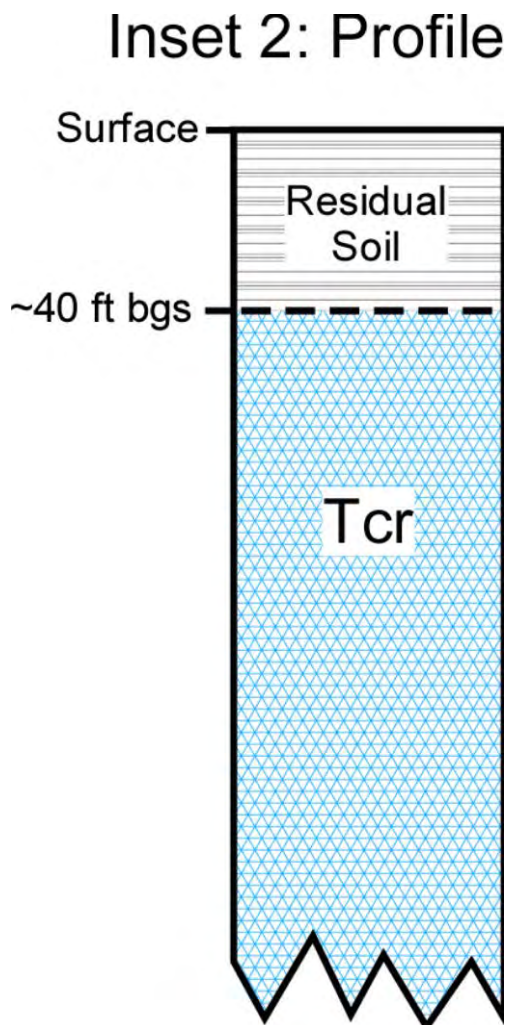
The estimated soil profile to bedrock is shown on Inset 2.

Based on review of the geologic map<sup>55</sup>, the site is underlain by Columbia River Basalt. The Columbia River Basalt consists of numerous fine-grained lava flows that primarily erupted from fissures in eastern Washington and Oregon and western Idaho during the Miocene (23.8 to 5.3 million years ago). A thick, clay-rich residual soil often forms on the upper portion of the Columbia River Basalt from the in-place weathering of the rock. The Columbia River Basalt is several thousand feet thick in the vicinity of the site.

The materials encountered in the upper portion of our explorations at the site were not consistent with descriptions of decomposed Columbia River Basalt mapped within the area. The materials consisted of decomposed volcanoclastic sediments and heavily weathered basalt. These soils extended to at least 61 feet bgs at the site (the deepest point explored during this investigation). Logs of wells in the vicinity of the site indicate intact, hard, basalt bedrock is generally encountered within about 10 feet of the ground surface. Numerous ancient (non-active) faults are located within the vicinity of the site, which may explain the presence of the localized deep soils. Additional deep borings and/or geophysical surveys could be performed to refine the geology within the vicinity of the site. However, based on the very stiff to hard consistencies of the soils encountered in the borings, the additional exploration would be of limited benefit to the analysis and design of the proposed project.

#### B.3.2 Site Class Determination

Section 1613.3.2 of the 2014 OSSC requires that the determination of the seismic site class be based on subsurface data in accordance with Chapter 20 of the ASCE 7-10. CGT chose to use Standard Penetration Test (SPT) N-values for determination of the site classification for this project. The SPT subsurface exploration method is described in the geotechnical investigation report. Boring B-1 was advanced to a depth of about 61 feet bgs and terminated in hard sandy clay. Chapter 20 of ASCE 7-10 requires that the stiffness of the soils be measured or reasonably estimated for the upper 100 feet bgs. As discussed in Section B.3.1, basalt bedrock is anticipated to extend to depths of several thousand feet bgs. The materials encountered in the deeper portions of the borings was consistent with the



<sup>55</sup> Madin, I.P., 2009, Geologic map of the Oregon City 7.5' quadrangle, Clackamas County, Oregon: Oregon Department of Geology and Mineral Industries, Geological Map Series 119, scale 1:24,000.

decomposed basalt mapped in the area of the site. To satisfy code requirements we averaged the SPT N-values from B-1 from 45 to 61 feet bgs, and extrapolated the results to a depth of 100 feet bgs. The results of the site class calculations are shown in the following table.

**Table B4 Calculation for Determination of Site Classification**

Bottom Depth (feet)	Soil Type	Field SPT (N <sub>i</sub> )	Layer Thickness [d <sub>i</sub> ] (feet)	d <sub>i</sub> /N <sub>i</sub>
1.5	CL-CH	15	1.5	0.10
4	CL-CH	17	2.5	0.15
7.4	CL	17	3.4	0.20
11.5	CL	8	4.1	0.51
14	CL	14	2.5	0.18
16.5	CL	22	2.5	0.11
20.9	CL	100	4.4	0.04
26.5	CL	28	5.6	0.20
30.9	CL	100	5	0.05
36.5	SC	19	5	0.26
41.5	SC	46	5	0.11
46.5	SC	75	5	0.07
50.4	SC	100	3.9	0.04
56.5	CL	44	6.1	0.14
60.9	CL	100	4.4	0.04
100	CL	80 (average of previous 4 readings)	39.1	0.49
<b>TOTALS</b>			<b>100.0</b>	<b>2.69</b>
Geometric Mean: (ASCE 7-10 Section 20.4.2 Equation 40.4.-2)		$\bar{N} = \frac{\sum_{i=1}^n d_i}{\sum_{i=1}^n \frac{d_i}{N_i}} = 37.17$		

Based on the guidelines presented in Table 20.3-1 in Chapter 20 of the ASCE 7-10, the project site is designated as Site Class D.

#### **B.4.0 SEISMIC DESIGN**

##### **B.4.1 Seismic Ground Motion Values**

Earthquake ground motion parameters for the site were obtained based on the United States Geological Survey (USGS) Seismic Design Values for Buildings - Ground Motion Parameter Calculator<sup>56</sup>. The following table shows the recommended seismic design parameters for the site.

<sup>56</sup> United States Geological Survey, 2015. Seismic Design Parameters determined using: "U.S. Seismic Design Maps Web Application," from the USGS website <http://geohazards.usgs.gov/designmaps/us/application.php>.

**Table B5 Seismic Ground Motion Values**

Parameter		Value
Mapped Acceleration Parameters	Spectral Acceleration, 0.2 second ( $S_s$ )	0.945g
	Spectral Acceleration, 1.0 second ( $S_1$ )	0.407g
Coefficients (Site Class D)	Site Coefficient, 0.2 sec. ( $F_A$ )	1.122
	Site Coefficient, 1.0 sec. ( $F_V$ )	1.593
Adjusted MCE Spectral Response Parameters	MCE Spectral Acceleration, 0.2 sec. ( $S_{MS}$ )	1.060g
	MCE Spectral Acceleration, 1.0 sec. ( $S_{M1}$ )	0.648g
Design Spectral Response Accelerations	Design Spectral Acceleration, 0.2 seconds ( $S_{DS}$ )	0.707g
	Design Spectral Acceleration, 1.0 second ( $S_{D1}$ )	0.432g

Based on Section 1613.3.5 of the 2014 OSSC, the site falls into a Seismic Design Category D.

The recommendations presented above were based on design procedures presented in Section 11.4 of ASCE 7-10. A site-specific response analysis could be performed to develop a site-specific design response spectrum at the owner's discretion, if desired, for an additional fee.

## **B.5.0 SEISMIC HAZARDS**

### **B.5.1 Liquefaction**

#### **B.5.1.1 Overview**

In general, liquefaction occurs when deposits of loose/soft, saturated, cohesionless soils, generally sands and silts, are subjected to strong earthquake shaking. If these deposits cannot drain quickly enough, pore water pressures can increase, approaching the value of the overburden pressure. The shear strength of a cohesionless soil is directly proportional to the effective stress, which is equal to the difference between the overburden pressure and the pore water pressure. When the pore water pressure increases to the value of the overburden pressure, the shear strength of the soil reduces to zero, and the soil deposit can liquefy. The liquefied soils can undergo rapid consolidation or, if unconfined, can flow as a liquid. Structures supported by the liquefied soils can experience rapid, excessive settlement, shearing, or even catastrophic failure.

The susceptibility of sands, gravels, and sand-gravel mixtures to liquefaction is typically assessed based on penetration resistance, as measured using SPTs, CPTs, or Becker Hammer Penetration tests (BPTs). For fine-grained soils, susceptibility to liquefaction is evaluated based on penetration resistance and plasticity, among other characteristics. Criteria for identifying non-liquefiable, fine-grained soils are constantly evolving. Current practice to identify non-liquefiable, fine-grained soils is based on plasticity characteristics of the soils, as follows: (1) liquid limit greater than 47 percent, (2) plasticity index greater than 20 percent, and (3) moisture content less than 85 percent of the liquid limit<sup>57</sup>.

<sup>57</sup> Seed, R.B. et al., 2003. Recent Advances in Soil Liquefaction Engineering: A Unified and Consistent Framework. Earthquake Engineering Research Center Report No. EERC 2003-06.

Review of hazard mapping available at the Oregon Statewide Geohazards Viewer website<sup>58</sup> indicates the site and immediate vicinity are shown as having no hazard associated with soil liquefaction (non-liquefiable).

Based on the findings of our explorations the soils encountered within our borings are considered non-liquefiable since they are above the groundwater level.

Based on the conditions encountered within our explorations, review of available mapping, and experience with similar soils in the area of the site, the risk of significant settlement at the site due to soil liquefaction during a design level earthquake is considered very low.

### **B.5.2 Slope Stability**

Due to the relatively flat to gently sloping topography of the site and vicinity, the risk of seismically-induced slope instability at the site is considered low.

### **B.5.3 Surface Rupture**

#### **B.5.3.1 Faulting**

As discussed above, the site is situated in a region of the country characterized by extensive faulting and known for seismic activity. The site is located approximately ¾-mile southwest of a strand of the Bolton Fault. However, no known faults are mapped on or immediately adjacent to the site, the risk of surface rupture impacting the proposed development at the site due to faulting is considered low.

#### **B.5.3.2 Lateral Spread**

Surface rupture due to lateral spread can occur on sites underlain by liquefiable soils that are located on or immediately adjacent to slopes steeper than about 3 degrees (20H:1V), and/or adjacent to a free face, such as a stream bank or the shore of an open body of water. During lateral spread, the materials overlying the liquefied soils are subject to lateral movement downslope or toward the free face. Given the lack of liquefiable soils at the site, the risk of surface rupture due to lateral spread is considered very low.

### **B.5.4 Tsunami/Seiche Inundation**

The site is geographically remote to the Oregon coast and therefore not at risk of inundation from a tsunami occurring in the Pacific Ocean.

The term seiche refers to oscillating standing waves that can produce dramatic changes in water level over relatively short periods of time and can cause inundation of nearby areas. A seiche can be generated in enclosed or partially enclosed bodies of water by atmospheric conditions or seismic activity. The site is located near the top of the Tualatin Mountains in a relatively flat area, with no nearby bodies of water that could produce a seismically-induced seiche. Accordingly, the hazard associated with seiche inundation at the site is generally considered negligible.

---

<sup>58</sup> Oregon HazVu: Statewide Hazards Viewer, 2015. Oregon Department of Geology and Mineral Industries: <http://www.oregongeology.org/hazvu>

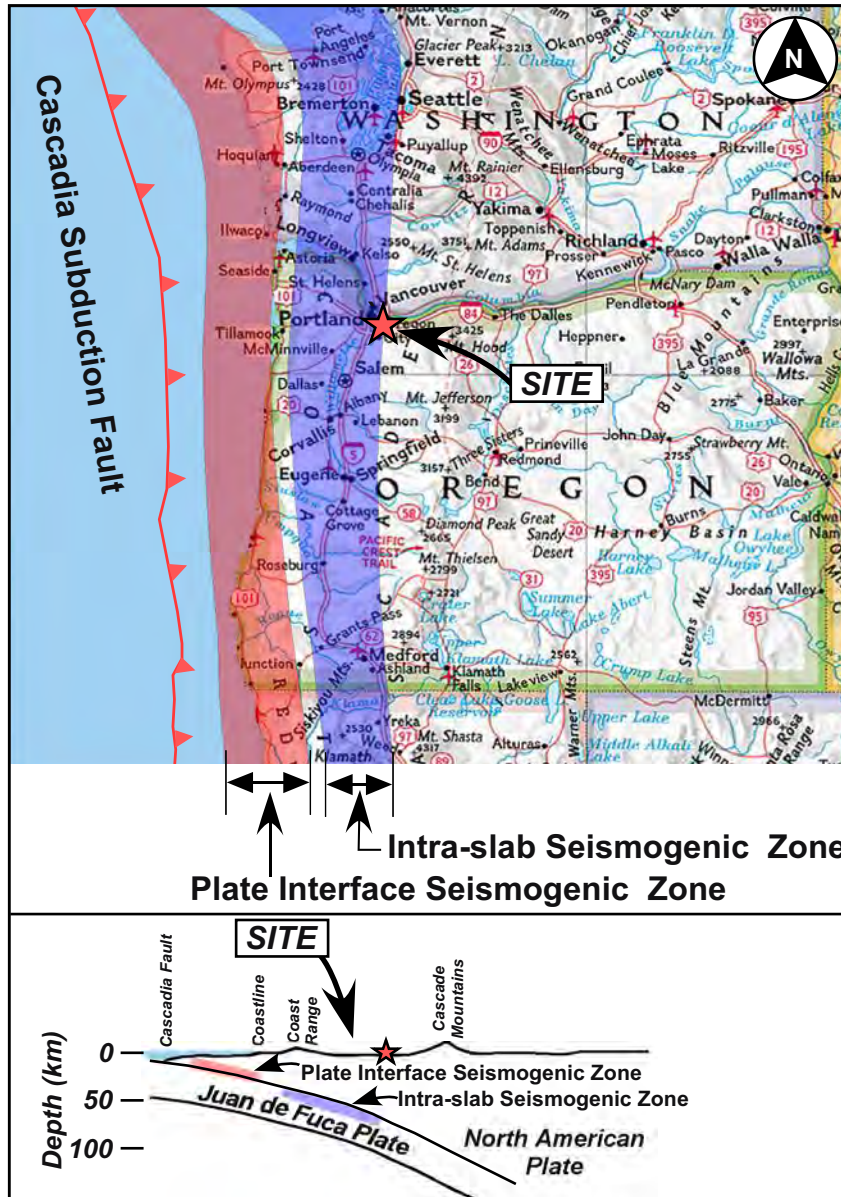
*Appendix B – Site Specific Seismic Hazards Study  
Sunset Primary School  
West Linn, Oregon  
CGT Project Number G1504201  
July 15, 2015*

#### **B.6.0 REPORT SUBMITTAL**

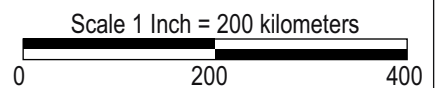
According to Section 1803.9 of the 2014 OSSC, the applicant should submit one copy of the Site-Specific Seismic Hazards Study to the building permit issuing agency (the jurisdiction), and one copy to the Oregon Department of Geology and Mineral Industries (DOGAMI). The DOGAMI report can be submitted to the following address:

DOGAMI – Site Specific Seismic Hazards Study  
Administrative Offices  
800 NE Oregon Street #28, Suite 965  
Portland, Oregon 97232

**CASCADIA SUBDUCTION ZONE**



McCrary, Blair, Oppenheimer, and Walter, 2004. Depth to the Juan de Fuca slab beneath the Cascadia subduction margin - A 3-D model for storing earthquakes: U.S. Geological Survey Data Series 91.



# Carlson Geotechnical

A Division of Carlson Testing, Inc.  
Phone: (503) 601-8250  
Fax: (503) 601-8254

Bend Office (541) 330-9155  
Eugene Office (541) 345-0289  
Salem Office (503) 589-1252  
Tigard Office (503) 684-3460



June 20, 2016

West Linn Wilsonville School District 3JT  
Attn: Mr. Remo Douglas  
2755 SW Borland Road  
Tualatin, Oregon 97062

## **Suitability of Proposed Stormwater Management Facility Sunset Primary School**

CGT Project Number G1504201.A

Dear Mr. Douglas:

Carlson Geotechnical (CGT) has prepared this letter to provide our opinion regarding the suitability of the proposed, on-site stormwater facility for the new Sunset Primary School project. CGT is the geotechnical engineer of record for this project and previously submitted our Report of Preliminary Geotechnical Investigation, Infiltration Testing & Site Specific Seismic Hazards Study, dated July 15, 2015.

We understand the following:

- One of the conditions of the City Council's land-use approval for this project is to provide an impervious, lined stormwater detention facility,
- KPFF, the project civil engineer, has recently provided the design of this stormwater facility in their storm report,
- The proposed impervious, lined stormwater detention facility will occupy an approximate 8,400 square-foot area and will be approximately 4 feet deep, and
- Will be lined with a pre-manufactured, geosynthetic clay liner (GCL), consisting of two layers of geotextiles surrounding a layer of low permeability sodium bentonite (i.e., clay).

This letter was prepared in response to the City of West Linn Development Engineering Supervisor, Mr. Khoi Le's comments on KPFF's storm report. Mr. Le's comments were received in an email forwarded to CGT by Mr. Remo Douglas of the West Linn Wilsonville School District (WLWSD) on June 17, 2016. One of Mr. Le's comments pertained to the above-referenced geotechnical report (attached to KPFF's storm report as Appendix A), requesting additional information be provided regarding the geotechnical suitability of the construction of an impervious lined stormwater detention facility at the site.

CGT is of the opinion that constructing an impervious, lined stormwater detention facility at the site will not cause any negative geotechnical impacts to the existing site conditions. Subgrade preparation should be completed in general accordance with the above-referenced CGT geotechnical report and per the GCL manufacturer's specific recommendations.

We appreciate the opportunity to work with you on this project. Please contact the undersigned if you have any questions regarding this letter.



June 20, 2016  
Sunset Primary School  
West Linn, Oregon  
CGT Project No. G1504201.A

Respectfully Submitted,  
**CARLSON GEOTECHNICAL**



EXPIRES: 12/31/2016

Jeffrey P. Quinn, P.E.  
Geotechnical Engineer  
[jquinn@carlsontesting.com](mailto:jquinn@carlsontesting.com)



Ryan T. Houser, CEG  
Senior Engineering Geologist  
[rhouser@carlsontesting.com](mailto:rhouser@carlsontesting.com)

Attachments: None

Doc ID: G:\GEOTECH\PROJECTS\2015 Projects\New Sunset Primary School\G1504201.A\008 - Deliverables\Impervious Storm Pond Letter.docx

# Appendix D

## Operations & Maintenance Report

# Operation and Maintenance Plan

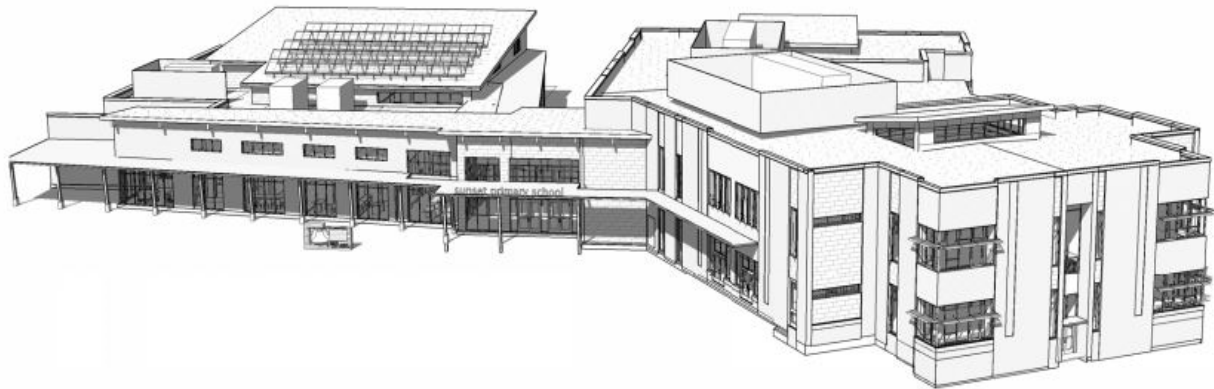
## Sunset Primary School

Prepared for: West Linn Wilsonville School District

Prepared by: Andrew Chung, Matt Johnson

Project Engineer: Mark Wharry, PE

June 2016 | KPFF Project #315087



#### KPFF'S COMMITMENT TO SUSTAINABILITY

As a member of the US Green Building Council, a sustaining member of Oregon Natural Step, and a member of the Sustainable Products Purchasers Coalition, KPFF is committed to the practice of sustainable design and the use of sustainable materials in our work.

When hardcopy reports are provided by KPFF, they are prepared using recycled and recyclable materials, reflecting KPFF's commitment to using sustainable practices and methods in all of our products.



## Table of Contents

I.	Description .....	4
II.	Schedule.....	4
III.	Inspection and Maintenance Procedures.....	5
IV.	Financial Responsibilities.....	6

## Appendix

### Appendix A

Facilities Specifications

### Appendix B

Inspection Log

# I. Description

The Sunset Primary School project is located at 2531 Oxford St. West Linn, Oregon. Currently, the site is occupied by the existing Sunset Primary school, baseball field, playground equipment and wooded area. The proposed project site is bound to the South by Oxford Street, Park Street, and Bittner Street, to the west by adjacent property, and to the north and east by woods (see Figure 1 – Vicinity Map). Currently, stormwater runoff from the project site is served by catch basins and surface runoff to public storm system on Exeter Street and Park Street.

The proposed project is an entire replacement of the Sunset Primary school building, asphalt parking lots, sidewalks, landscape, plays areas, and sports fields. All of this redevelopment will require stormwater treatment and detention. One adequately sized stormwater facility will meet City of West Linn Design Standards Section 2 Storm Drain requirements. The drainage area for the total project area is approximately 4.8 acres.

Water quality facilities used on property (see Storm Plans for location):

- *Planters*: A vegetated landscaped reservoir used to collect, filter, and infiltrate stormwater. The stormwater is treated as it percolates through the vegetation, growing medium, and gravel. Each has an open bottom, allowing for infiltration into the native soil to occur. It has an overflow pipe that will discharge into the drywell system.
- *Piped Storm System*: The piped storm system consists of all underground pipes and structures that connect the roof drains, drywells, overflows, and rain gardens.
- *Rain Garden*: An engineered planter that filters pollutants out of stormwater as it passes through engineered growing medium prior to infiltration. The rain garden contains an overflow inlet structure that conveys excess stormwater from large rain events to public storm system and rip rap protection at inlets to prevent erosion and damage to the planter soil and vegetation.
- *Trapped Catch Basin*: A 24-inch square basin that collects stormwater runoff, traps debris, and conveys runoff into the stormwater system.
- *Overflow Inlet*: A vertical pipe with a grate over it that allows stormwater from large rain events to enter the downstream storm system. The grate prevents debris and rodents from entering the piped storm system.
- *Sedimentation Manhole*: A manhole with a sump to collect sediment and a down-turned elbow to prevent floatables from entering the piped system. This structure prevents debris and sediment from entering the drywell manholes.

## II. Schedule

Each part of the system shall be inspected and maintained quarterly within the first two years. After two years, all facilities should be inspected twice a year. All facilities should be inspected 48 hours after each major storm event. For this O&M Plan, a major storm event is defined as 1 inch of rain or more in 24 hours. All components of the storm system as described above must be inspected and maintained frequently or they will cease to function effectively. The facility owner shall keep a log, recording all inspection dates, observations, and maintenance activities. Receipts shall be saved when maintenance is performed and there is record of expense.

## III. Inspection and Maintenance Procedures

The following items shall be inspected and maintained as stated:

### Piped Storm System

- Sediment shall be removed biannually.
- Debris shall be removed from inlets and outlets quarterly.
- Quarterly inspection for clogging shall be performed.
- Grates shall be tamper proof.

Source Control measures prevent pollutants from mixing with stormwater. Typical non-structural control measures include raking and removing leaves, street sweeping, vacuum sweeping, and limited and controlled application of pesticides, herbicides, and fertilizers.

- Source control measures shall be inspected and maintained quarterly.
- Signage shall be maintained.

Spill Prevention measures shall be exercised when handling substances that can contaminate stormwater. Virtually all sites, including residential and commercial, present dangers from spills. It is important to exercise caution when handling substances that can contaminate stormwater. Activities that pose the chance of hazardous material spills shall not take place near collection facilities.

- The proper authority and the property owner shall be contacted immediately if a spill is observed.
- A spill kit shall be kept near spill-prone operations and refreshed annually.
- Employees shall be trained on spill control measures.
- Shut-off valves shall be tested quarterly.
- Releases of pollutants shall be corrected within 12 hours.

Insects and Rodents shall not be harbored in any part of the storm system.

- Pest control measures shall be taken when insects/rodents are found to be present. Standing water and food sources shall be prevented.
- If sprays are considered, a mosquito larvicide such as Bacillus thurendensis or Altoside formulations can be applied only if absolutely necessary and shall not be used where it will enter groundwater or come into contact with any standing water. Sprays shall be applied only by licensed individuals or contractors.
- Holes in the ground located in and around the storm system shall be filled.

- Outfalls draining into vegetated swales shall be inspected and cleaned regularly to ensure no rodent activity, which can clog or decrease the efficiency of the storm system.

Access shall be maintained for all facilities so operations and maintenance can be performed as regularly scheduled.

- Existing drywells shall be raised with a locking manhole cover to ensure access.

## **IV. Financial Responsibilities**

The facility is to be maintained by West Linn Wilsonville School District. The preparer has worked closely with personnel to design a system that can be easily maintained by maintenance staff.

The West Linn Wilsonville School District Facilities Manager is Pat McGough (503-673-7975).

*A copy of the O&M Plan shall be provided to the property owner.*



# Appendix A

## Facilities Specifications

## Simplified O&M Specifications BASINS

Maintenance Indicator	Corrective Action
<p><b>Structural Components</b>, including inlets and outlets/overflows, shall freely convey stormwater.</p>	
<ul style="list-style-type: none"> <li>➤ Clogged inlets or outlets</li> <li>➤ Broken inlets or outlets, including grates</li> <li>➤ Cracked or exposed drain pipes</li> <li>➤ Check dams</li> </ul>	<ul style="list-style-type: none"> <li>➤ Remove sediment and debris from catch basins, trench drains, curb inlets, and pipes to maintain at least 50% conveyance capacity at all times.</li> <li>➤ Repair or replace broken downspouts, curb cuts, standpipes, and screens as needed.</li> <li>➤ Repair/seal cracks. Replace when repair is insufficient. Cover with 6 inches of growing medium to prevent freeze/thaw and UV damage.</li> <li>➤ Maintain rock check dams per design standards.</li> </ul>
<p><b>Vegetation</b> shall cover 90% of the facility.</p>	
<ul style="list-style-type: none"> <li>➤ Dead or strained vegetation</li> <li>➤ Tall grass and vegetation</li> <li>➤ Weeds</li> </ul>	<ul style="list-style-type: none"> <li>➤ Replant per original planting plan, or substitute from <a href="#">Appendix F.4</a> plant list.</li> <li>➤ Irrigate as needed. Mulch banks as needed. DO NOT apply fertilizers, herbicides, or pesticides.</li> <li>➤ Prune to allow sight lines and foot traffic. Prune to ensure inlets and outlets freely convey stormwater into and/or out of the facility. Manually remove weeds. Remove all plant debris.</li> </ul>
<p><b>Growing/Filter Medium</b>, including soil and gravels, shall sustain healthy plant cover and infiltrate within 48 hours.</p>	
<ul style="list-style-type: none"> <li>➤ Erosion, and/or exposed soils</li> <li>➤ Scouring at inlet(s)</li> <li>➤ Slope slippage</li> <li>➤ Ponding</li> </ul>	<ul style="list-style-type: none"> <li>➤ Fill and lightly compact areas of erosion with City-approved soil mix. Stabilize soils with plantings from <a href="#">Appendix F.4</a>.</li> <li>➤ Replace splash pads at inlet(s) with gravel/rock.</li> <li>➤ Stabilize 3:1 slopes/banks with plantings from <a href="#">Appendix F.4</a>.</li> <li>➤ Remove the top 2-4 inches of sediment at the inlet. Add City-approved soil mix to match elevation of the inlet. Rake, till, or amend with City-approved soil mix to restore infiltration rate.</li> </ul>

**Maintenance Schedule:**

*Summer:* Make any structural repairs. Improve filter medium as needed. Clear drains and inlets. Irrigate as needed.

*Fall:* Replant exposed soil and replace dead plants. Remove sediment and plant debris.

*Winter:* Monitor infiltration/flow-through rates. Clear inlets and outlets/overflows to maintain conveyance.

*Spring:* Remove sediment and plant debris. Replant exposed soil and replace dead plants. Mulch as needed but do not block the inlets, outlets, or flow paths with mulch.

*All seasons:* Weed as necessary.

**Maintenance Records:**

*All maintenance operators are required to keep an annual inspection and maintenance log.*

Record the date, description, and contractor (if applicable) for all structural repairs, landscape maintenance, and facility cleanout activities. Keep work orders and invoices on file and make available upon request of the City inspector.

**Access:** Maintain ingress/egress, including access roads, to design standards.

**Infiltration/Flow Control:** All facilities shall drain within 48 hours. Record the time/date, weather, and site

conditions when ponding occurs.

**Pollution Prevention:** All sites shall implement BMPs to prevent hazardous or solid wastes or excessive oil and sediment from contaminating stormwater. Contact Spill Prevention & Citizen Response at 503-823-7180 for immediate assistance responding to spills. Record the time/date, weather, and site conditions if site activities contaminate stormwater. Record the time/date and description of corrective action taken.

**Vectors (Mosquitoes and Rodents):** Stormwater facilities shall not harbor mosquito larvae or rats that pose a threat to public health or that undermine the facility structure. Monitor standing water for small wiggling sticks perpendicular to the water's surface. Note holes/burrows in and around facilities. Call Multnomah County Vector Control at 503-988-3464 for immediate assistance to eradicate vectors. Record the time/date, weather, and site conditions when vector activity is observed.

# Appendix B

## Inspection Log



# Appendix E

## Offsite Stormwater Drainage Summary Memo

# Memorandum

Page 1 of 3



**DATE:** May 6, 2016

**PROJECT:** 315087-Sunset Primary School Public Improvements      **SUBJECT:** Storm Drainage Summary

**TO:** Khoi Le  
City of West Linn      **FROM:** Tyson Leggate  
KPFF Consulting Engineers

**PHONE:** 503-722-5517      **PHONE:** 503-542-3831

**EMAIL:** kle@westlinnoregon.gov      **EMAIL:** tyson.leggate@kpff.com

## Calculations Overview

Each basin described below flows toward a Flow-Through Planter (FTP), which is sized per the City of Portland PAC Calculator to meet the water quality event. The FTPs each have the following characteristics (unless noted otherwise):

- Assumed infiltration rate of 1 inch/hour
- Stormwater Hierarchy 2 (on-site infiltration, with overflow)
- Facility Configuration C
- 18 inches of growing media
- 12 inches of rock storage
- Underdrain pipe included in rock storage
- Planter (sloped) OR planter (flat) as outlined below

See the attached basin map and PAC Calculator calculations form more information on each basin and facility.

## Basin Summaries

**Basin A** is an area along Oxford Street, west of Exeter Street and north of the right-of-way centerline. The basin has 10,530 square feet of new and existing impervious area and slopes from NW to SE at 3% - 6% slopes toward a FTP-A. A concrete inlet conveys the water into the sloped FTP, which has a longitudinal slope of 4.5%. The FTP is divided into 2 bays of varying length and width that are divided by a check dam. The FTP may overflow via a curb notch into the street gutter line and a storm inlet located downstream. The PAC calculations prove that the planter passes the routing of the pollution reduction storm with 199 square feet of infiltration area and using 69% of the surface capacity.

**Basin B** is an area along Oxford Street, west of Exeter Street and south of the right-of-way centerline. The basin has 13,100 square feet of new and existing impervious area and slopes from NW to SE at 3% - 6% slopes toward a FTP-B. A concrete inlet conveys the water into the sloped FTP, which has a longitudinal slope of 3.4%. The FTP is divided into 3 bays of varying length and width that are divided by check dams. The FTP may overflow via a curb notch into the street gutter line and a storm inlet located downstream.



# Memorandum

Page 2 of 3  
May 6, 2016



The PAC calculations prove that the planter passes the routing of the pollution reduction storm with 218 square feet of infiltration area and using 100% of the surface capacity.

**Basin C** is an area along Oxford Street, east of Exeter Street and north of the right-of-way centerline. The basin has 5,900 square feet of new impervious area and slopes from east to west at 1% - 1.5% toward FTP-C. A concrete inlet conveys the water into the flat FTP, which is 110 square feet in size. The FTP may overflow via a curb notch into the street gutter line and a storm inlet located downstream. The PAC calculations prove that the planter passes the routing of the pollution reduction storm using 83% of the surface capacity.

**Basin D** is an area along Oxford Street, east of Exeter Street and south of the right-of-way centerline. The basin has 5,150 square feet of new impervious area and slopes from east to west at 1% - 1.5% slopes toward FTP-D. A concrete inlet conveys the water into the flat FTP, which is 100 square feet in size. The FTP may overflow via a curb notch into the street gutter line and a storm inlet located downstream. The PAC calculations prove that the planter passes the routing of the pollution reduction storm using 57% of the surface capacity.

**Basin E** is an area along Bittner Street, south of Oxford Street and east of the right-of-way centerline, encompassing a majority of the new impervious area proposed. The basin has 5,750 square feet of new impervious area and slopes from north to south at 5.4% slope toward a FTP-E. A scupper drain conveys the water into the sloped FTP, which has a longitudinal slope of 5.4%. The FTP is divided into 2 bays of varying length and width that are divided by a check dam. The FTP may overflow via a curb notch into the street gutter line and a storm inlet located downstream. The PAC calculations prove that the planter passes the routing of the pollution reduction storm with 121 square feet of infiltration area and using 39% of the surface capacity.

**Basin F** is an area along Bittner Street, south of Oxford Street and west of the right-of-way centerline, encompassing a large portion of the new impervious area proposed. The basin has 4,650 square feet of new impervious area and slopes from north to south at 5.4% slope toward a FTP-F. A scupper drain conveys the water into the sloped FTP, which has a longitudinal slope of 5.4%. The FTP is divided into 2 bays, 6.5 feet wide and 8.0 feet long, which are separated by a check dam. The FTP may overflow via a curb notch into the street gutter line and a storm inlet located downstream. The PAC calculations prove that the planter passes the routing of the pollution reduction storm, with 89 square feet of infiltration area and using 36% of the surface capacity.

**Area X** is 10,250 square feet of new impervious area, which could not be conveyed into a FTP facility. The area is at the intersection of Oxford Street and Exeter Street (5,790 square feet) and south of the new FTP planters on Bittner Street (4,460 square feet). However, this untreated area is much less than the additional amount of existing impervious area being treated from Basins A & B to more than offset this area.



# Memorandum

Page 3 of 3  
May 6, 2016



## Table Summary

Basin	Ownership	Storm Facility	Source (Roof, Road or Other)	Total Imp. Area (sf)	New Imp. Area (Non-roof) (sf)	Facility Max. Wet Area (sf)	Actual Sizing Factor (Facility Area/ Total Imp. Area)
Basin A	Public	A	Road, Sidewalk	10,530	5,200	220	2.0%
Basin B	Public	B	Road, Sidewalk	13,100	6,050	210	1.9%
Basin C	Public	C	Road, Sidewalk	5,900	5,900	110	1.9%
Basin D	Public	D	Road, Sidewalk	5,150	5,150	100	2.2%
Basin E	Public	E	Road, Sidewalk	5,750	5,750	130	2.9%
Basin F	Public	F	Road, Sidewalk	4,650	3,850	100	2.4%
Area X	Public	N/A	Road, Sidewalk	10,250	10,250	N/A	N/A

## Detention

The stormwater planters in the right of way do not need to account for meeting any detention requirements because the net impervious area of the area of disturbance is decreased. Table 2 below compares the existing and proposed impervious areas within the area of disturbance.

	Impervious Surface Area (sf)	Pervious Surface Area (sf)	Total Site Area* (sf)
Existing	44,240	5,060	49,300
Post-Development	40,670	8,630	49,300

\*=within area of disturbance

AREA X

FTP-D

BASIN D

BASIN E

BASIN F

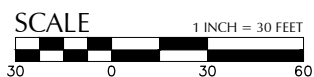
FTP-F

FTP-E

AREA X

File: N:\c\p\2015\315087-Sunset-Primary-School\CAD\LOT\PUBLIC\PIC0.6-KEY.dwg TAB:MAP  
Plotted: 5/6/16 at 8:23am By: RQuinn  
22x34 XREFS: 5087-xsv 5087-xst 5087-xar X-LS 5087-pw-xst 5087-pw-xlb-22x34 A-Plan-1 x-MEP A-Plan-1-alt5

REVISION	DATE	DESCRIPTION	BY
	4/19/16	BID SET	



111 SW Fi  
Portland, 1  
O: 503.227.3251  
F: 503.224.4681  
www.kpff.com

# MASTER BASIN MAP



PLOT DATE: 5/6/16 8:23am  
PLOTTED BY: RQuinn  
DWG NAME: PIC0.6-KEY.dwg  
TAB NAME: MAP

2351 OXFORD ST, WEST LINN, OR 97088

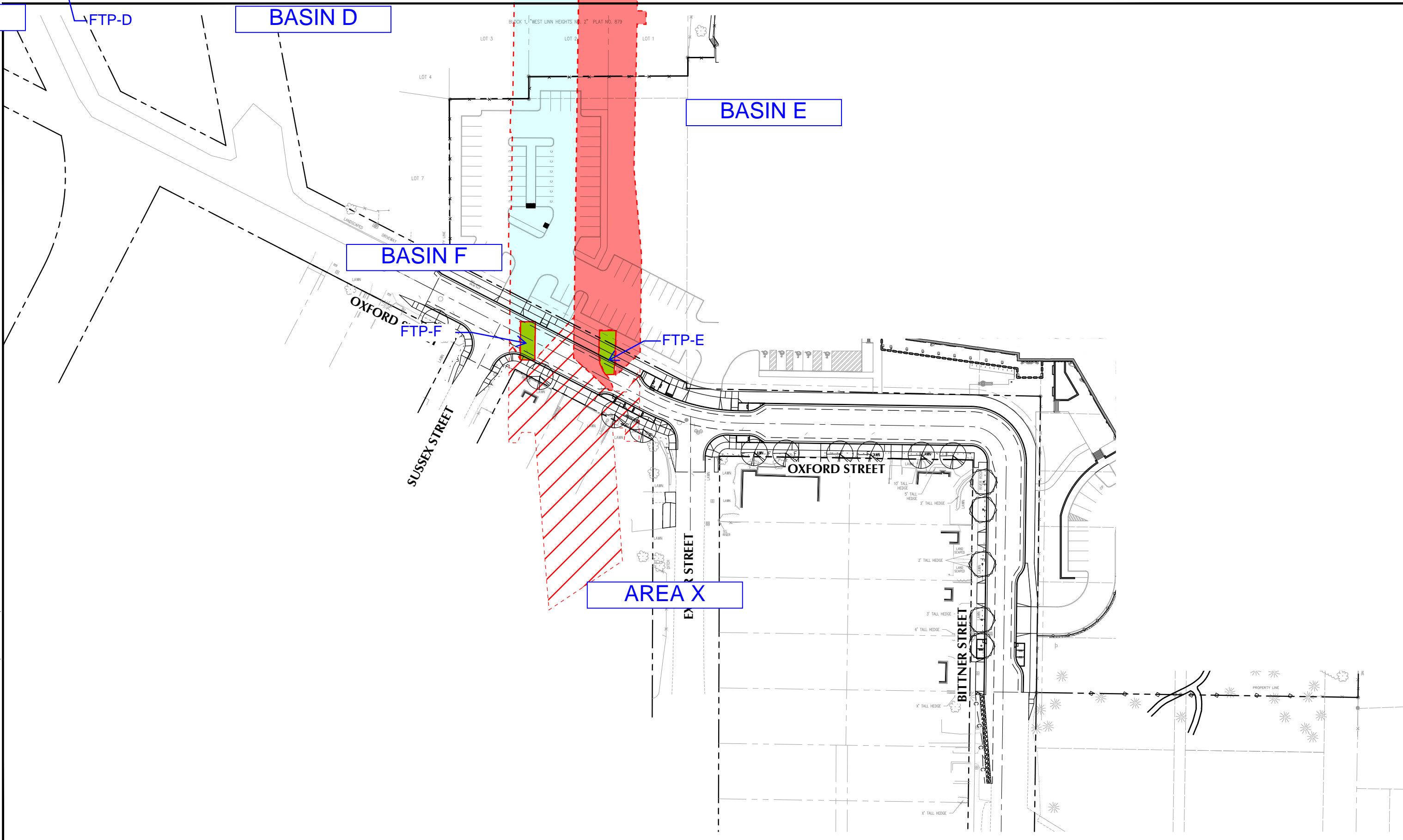
PUBLIC IMPROVEMENT PLANS  
SUNSET PRIMARY SCHOOL  
CITY OF WEST LINN, OR

HORIZONTAL CONTROL PLAN

SHEET NO.

# MAP

SHEET 5 OF 41  
RECORD NO.  
315087-5



# PAC Report

Project Name <b>315087 Sunset PS</b>	Permit No.	Created <b>5/3/16 5:25 PM</b>
Project Address <b>2351 Oxford Street West Linn, OR 97068</b>	Designer <b>Tyson Leggate</b>	Last Modified <b>5/5/16 8:15 PM</b>
	Company <b>KPFF Consulting Engineers</b>	Report Generated <b>5/5/16 8:15 PM</b>

## Project Summary

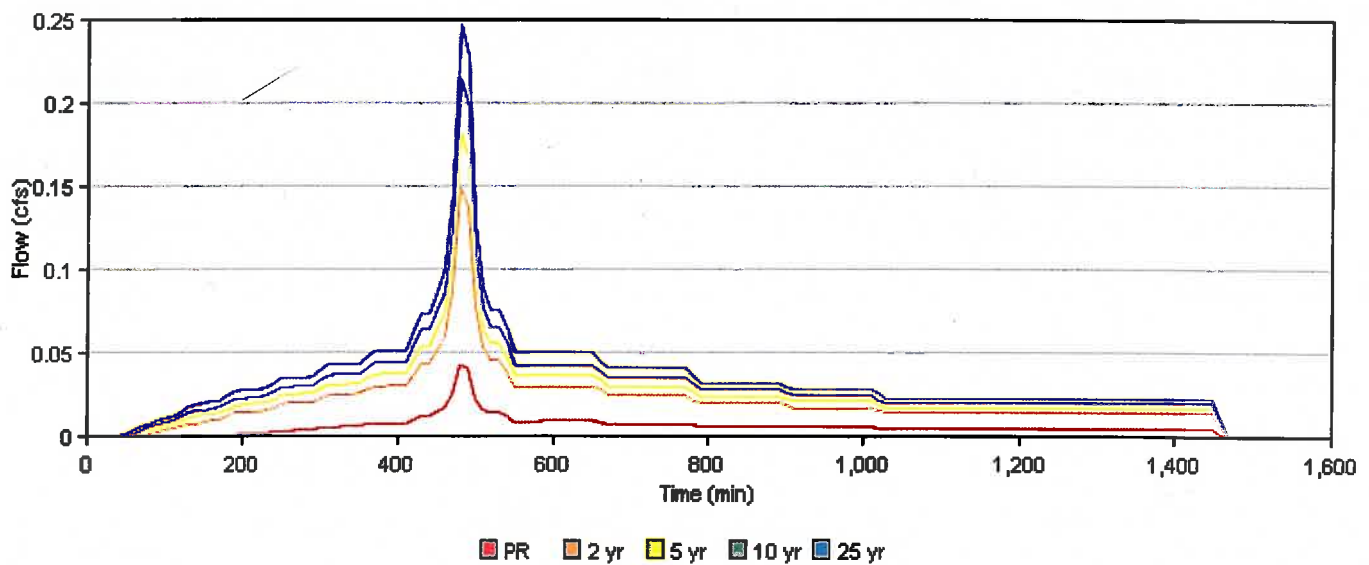
Public improvements to frontage of new school project.

Catchment Name	Impervious Area (sq ft)	Native Soil Design Infiltration Rate	Hierarchy Category	Facility Type	Facility Config	Facility Size (sq ft)	Facility Sizing Ratio	PR Results	Flow Control Results
A	10530	1.00	2	Planter (Sloped)	C		2%	Pass	Not Used
B	13100	1.00	2	Planter (Sloped)	C		1.9%	Pass	Not Used
C	5900	1.00	2	Planter (Sloped)	C		1.9%	Pass	Not Used
D	5150	1.00	2	Planter (Sloped)	C		2.2%	Pass	Not Used
E	5750	1.00	2	Planter (Sloped)	C		2.9%	Pass	Not Used
F	4650	1.00	2	Planter (Sloped)	C		2.4%	Pass	Not Used

## Catchment A

<b>Site Soils &amp; Infiltration Testing Data</b>	Infiltration Testing Procedure	<b>Open Pit Falling Head</b>
	Native Soil Infiltration Rate ( $I_{test}$ )	<b>1.00</b>
<b>Correction Factor</b>	$CF_{test}$	<b>2</b>
<b>Design Infiltration Rates</b>	Native Soil ( $I_{dsgn}$ )	<b>0.50 in/hr</b>
	Imported Growing Medium	<b>2.00 in/hr</b>
<b>Catchment Information</b>	Hierarchy Category	<b>2</b>
	Hierarchy Description	<b>On-site infiltration through use of approved UIC facility</b>
	Pollution Reduction Requirement	<b>Pass</b>
	10-year Storm Requirement	<b>Pass or if Fail, disposal through separate approved UIC</b>
	Flow Control Requirement	<b>Pass or if Fail, disposal through separate approved UIC</b>
	Impervious Area	<b>10530 sq ft 0.242 acre</b>
	Time of Concentration ( $T_c$ )	<b>5</b>
	Post-Development Curve Number ( $CN_{post}$ )	<b>98</b>

## SBUH Results



	Peak Rate (cfs)	Volume (cf)
PR	0.043	550.222
2 yr	0.149	1905.36

<b>5 yr</b>	0.182	2341.783
<b>10 yr</b>	0.214	2778.859
<b>25 yr</b>	0.247	3216.347

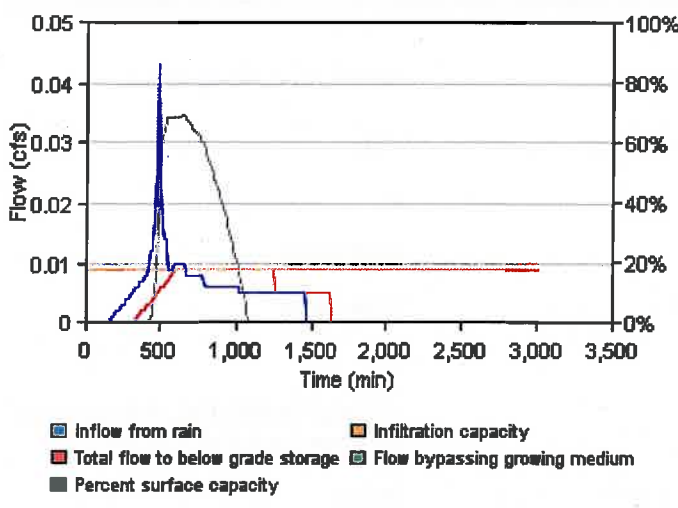
# Facility A

<b>Facility Details</b>	Facility Type	<b>Planter (Sloped)</b>
	Facility Configuration	<b>C: Infl. with RS and underdrain (Ud)</b>
	Facility Shape	<b>Sloped</b>
	<b>Above Grade Storage Data</b>	
	Growing Medium Depth	<b>18 in</b>
	Surface Capacity at Depth 1	<b>114.3 cu ft</b>
	Design Infiltration Rate for Native Soil	<b>0.002 in/hr</b>
	Infiltration Capacity	<b>0.009 cfs</b>
	<b>Below Grade Storage Data</b>	
	Rock Storage Depth	<b>12 in</b>
	Rock Porosity	<b>0.30 in</b>
	Storage Depth 3	<b>6.0 in</b>
<b>Facility Facts</b>	Total Facility Area Including Freeboard	<b>211.00 sq ft</b>
	Sizing Ratio	<b>2%</b>
<b>Pollution Reduction Results</b>	Pollution Reduction Score	<b>Pass</b>
	Overflow Volume	<b>346.930 cf</b>
	Surface Capacity Used	<b>69%</b>
	Rock Capacity Used	<b>100%</b>
<b>10 Year Results</b>	10 Year Score	<b>Fail</b>
	Overflow Volume	<b>2536.303 cf</b>
	Surface Capacity Used	<b>100%</b>
	Rock Capacity Used	<b>100%</b>

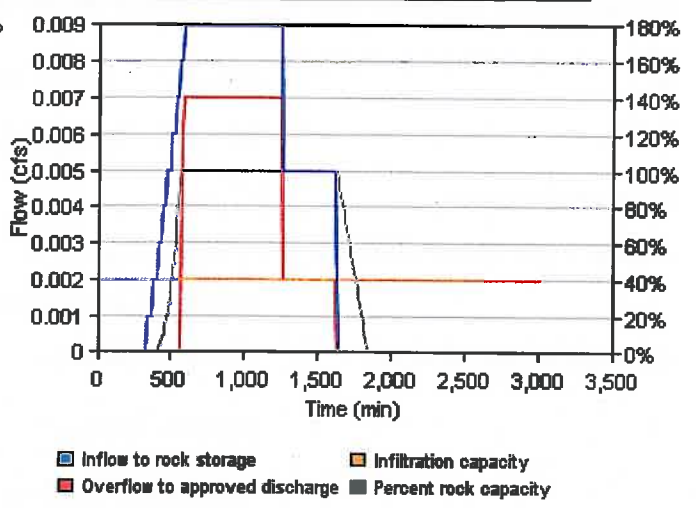
## Sloped Facility Worksheet

#	Segment Length (ft)	Check Dam Length (ft)	Slope, v/h (ft/ft)	Bottom Width (ft)	Right Side Slope, h/v (ft/ft)	Left Side Slope, h/v (ft/ft)	Downstream Depth (in)	Landscape Width (ft)	Rock Storage Width (ft)
1	8.50	0.50	0.0250	8.00	0.0	0.0	9.5	8.00	8.00
2	7.30	0.50	0.0250	10.00	0.0	0.0	8.0	10.00	9.00
3	7.00	0.50	0.0250	10.00	0.0	0.0	6.0	10.00	9.00

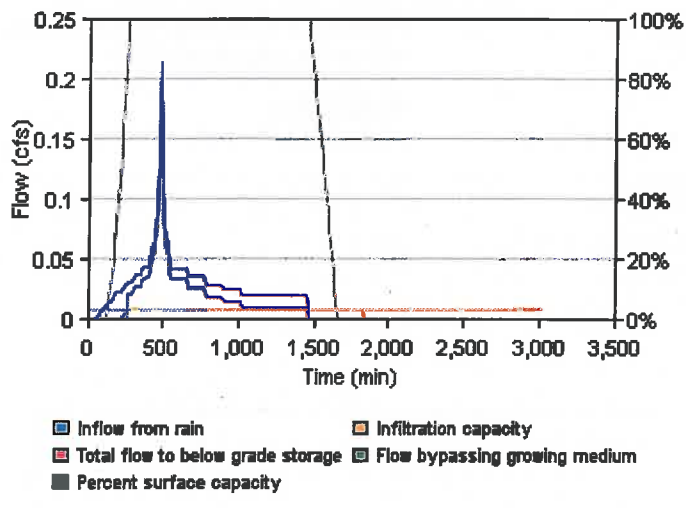
**Pollution Reduction Event Surface Facility Modeling**



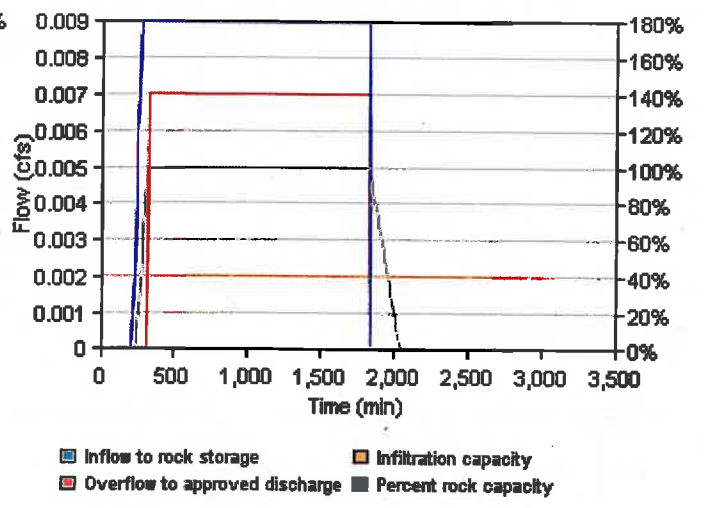
**Pollution Reduction Event Below Grade Modeling**



**10 Year Event Surface Facility Modeling**



**10 Year Event Below Grade Modeling**



## Catchment B

### Site Soils & Infiltration Testing Data

Infiltration Testing Procedure

Open Pit Falling Head

Native Soil Infiltration Rate ( $I_{test}$ )

1.00

### Correction Factor

$CF_{test}$

2

### Design Infiltration Rates

Native Soil ( $I_{dsgn}$ )

0.50 in/hr

Imported Growing Medium

2.00 in/hr

### Catchment Information

Hierarchy Category

2

Hierarchy Description

On-site infiltration through use of approved UIC facility

Pollution Reduction Requirement

Pass

10-year Storm Requirement

Pass or if Fail, disposal through separate approved UIC

Flow Control Requirement

Pass or if Fail, disposal through separate approved UIC

Impervious Area

13100 sq ft  
0.301 acre

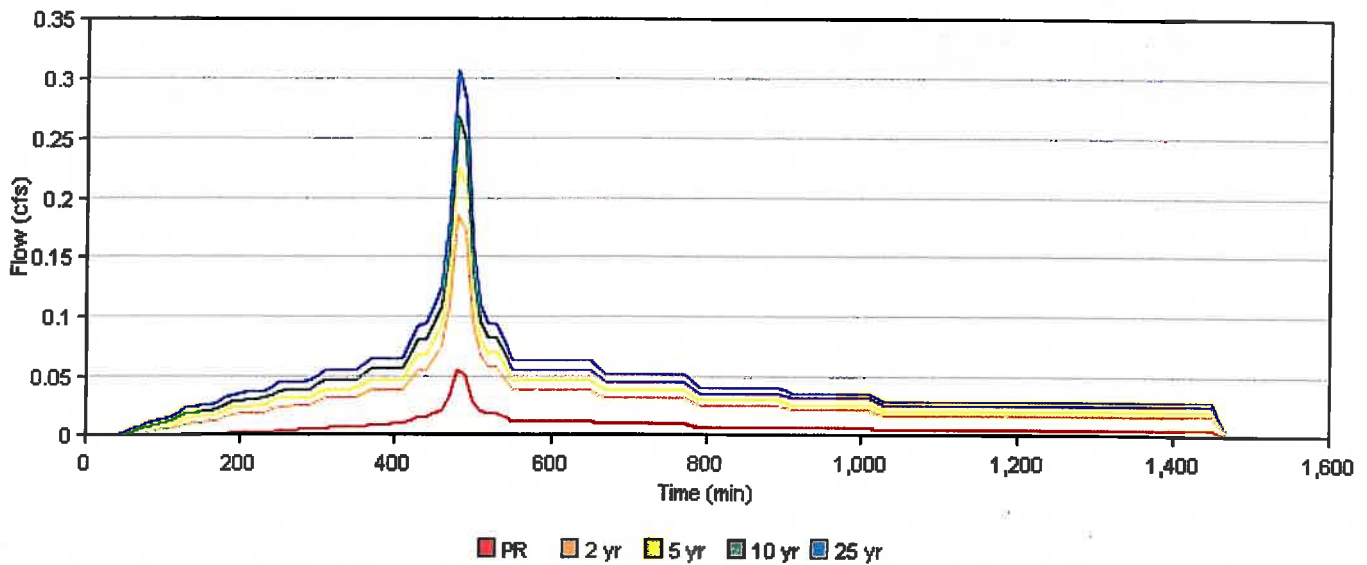
Time of Concentration ( $T_c$ )

5

Post-Development Curve Number ( $CN_{post}$ )

98

## SBUH Results



PR

Peak Rate (cfs)

0.054

Volume (cf)

684.512

2 yr

0.185

2370.391



<b>5 yr</b>	0.226	2913.329
<b>10 yr</b>	0.267	3457.08
<b>25 yr</b>	0.307	4001.343

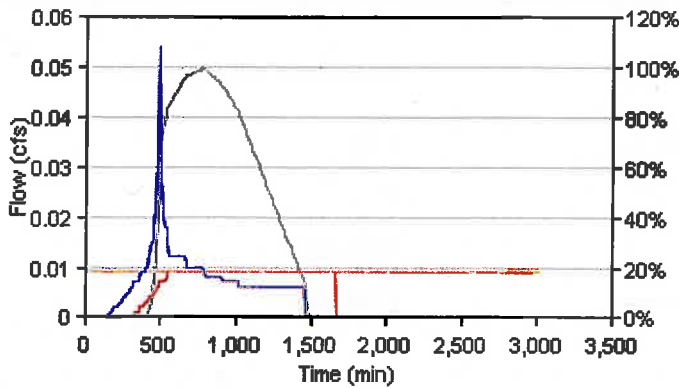
## Facility B

<b>Facility Details</b>	Facility Type	<b>Planter (Sloped)</b>
	Facility Configuration	<b>C: Infl. with RS and underdrain (Ud)</b>
	Facility Shape	<b>Sloped</b>
	<b>Above Grade Storage Data</b>	
	Growing Medium Depth	<b>18 in</b>
	Surface Capacity at Depth 1	<b>139.8 cu ft</b>
	Design Infiltration Rate for Native Soil	<b>0.002 in/hr</b>
	Infiltration Capacity	<b>0.009 cfs</b>
	<b>Below Grade Storage Data</b>	
	Rock Storage Depth	<b>12 in</b>
	Rock Porosity	<b>0.30 in</b>
	Storage Depth 3	<b>6.0 in</b>
<b>Facility Facts</b>	Total Facility Area Including Freeboard	<b>243.00 sq ft</b>
	Sizing Ratio	<b>1.9%</b>
<b>Pollution Reduction Results</b>	Pollution Reduction Score	<b>Pass</b>
	Overflow Volume	<b>465.078 cf</b>
	Surface Capacity Used	<b>100%</b>
	Rock Capacity Used	<b>100%</b>
<b>10 Year Results</b>	10 Year Score	<b>Fail</b>
	Overflow Volume	<b>3203.457 cf</b>
	Surface Capacity Used	<b>100%</b>
	Rock Capacity Used	<b>100%</b>

### Sloped Facility Worksheet

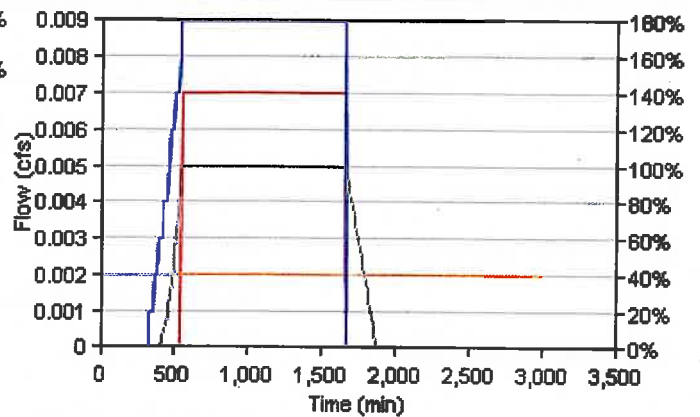
#	Segment Length (ft)	Check Dam Length (ft)	Slope, v/h (ft/ft)	Bottom Width (ft)	Right Side Slope, h/v (ft/ft)	Left Side Slope, h/v (ft/ft)	Downstream Depth (in)	Landscape Width (ft)	Rock Storage Width (ft)
1	12.20	0.50	0.0340	3.50	0.0	0.0	8.4	5.00	3.50
2	9.60	0.50	0.0340	4.50	0.0	0.0	9.6	5.00	4.50
3	9.00	0.50	0.0340	4.50	0.0	0.0	10.8	5.00	4.50
4	9.00	0.50	0.0340	4.50	0.0	0.0	10.8	5.00	4.50
5	8.80	0.50	0.0340	4.50	0.0	0.0	12.0	5.00	4.50

**Pollution Reduction Event Surface Facility Modeling**



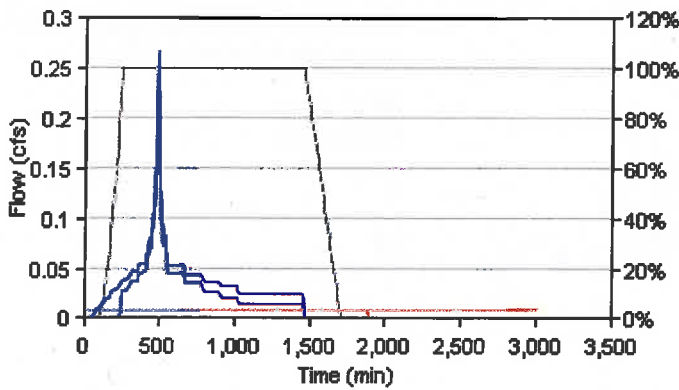
- Inflow from rain
- Total flow to below grade storage
- Percent surface capacity
- Infiltration capacity
- Flow bypassing growing medium

**Pollution Reduction Event Below Grade Modeling**



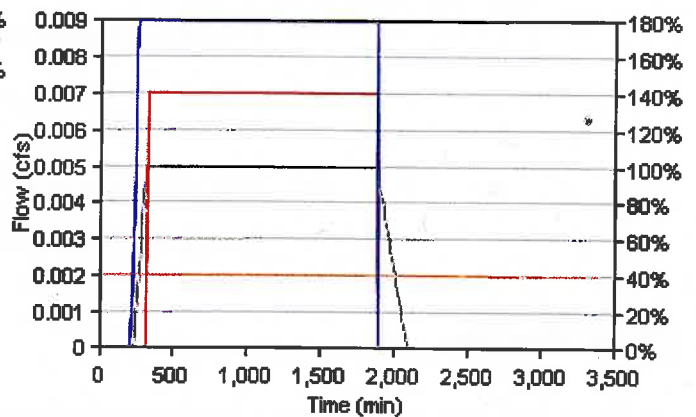
- Inflow to rock storage
- Overflow to approved discharge
- Percent rock capacity
- Infiltration capacity

**10 Year Event Surface Facility Modeling**



- Inflow from rain
- Total flow to below grade storage
- Percent surface capacity
- Infiltration capacity
- Flow bypassing growing medium

**10 Year Event Below Grade Modeling**



- Inflow to rock storage
- Overflow to approved discharge
- Percent rock capacity
- Infiltration capacity

## Catchment C

### Site Soils & Infiltration Testing Data

Infiltration Testing Procedure

Open Pit Falling Head

Native Soil Infiltration Rate ( $I_{test}$ )

1.00

### Correction Factor

$CF_{test}$

2

### Design Infiltration Rates

Native Soil ( $I_{dsgn}$ )

0.50 in/hr

Imported Growing Medium

2.00 in/hr

### Catchment Information

Hierarchy Category

2

Hierarchy Description

On-site infiltration through use of approved UIC facility

Pollution Reduction Requirement

Pass

10-year Storm Requirement

Pass or If Fail, disposal through separate approved UIC

Flow Control Requirement

Pass or if Fail, disposal through separate approved UIC

Impervious Area

5900 sq ft  
0.135 acre

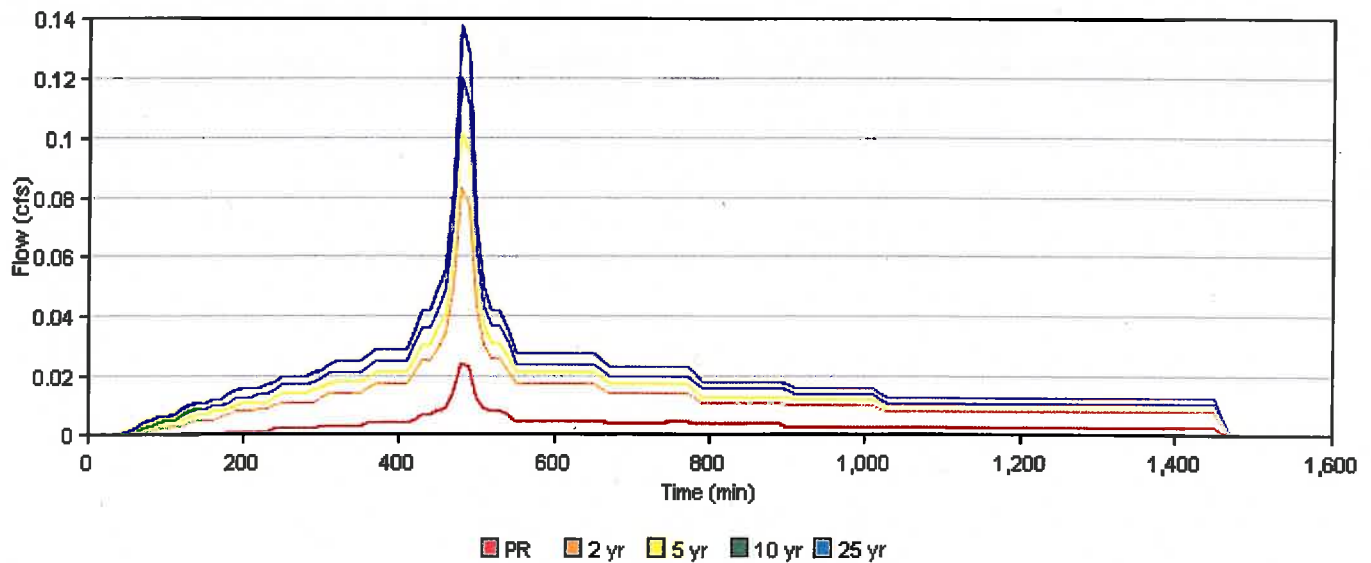
Time of Concentration ( $T_c$ )

5

Post-Development Curve Number ( $CN_{post}$ )

98

## SBUH Results



	Peak Rate (cfs)	Volume (cf)
PR	0.024	308.292
2 yr	0.083	1067.581

<b>5 yr</b>	<b>0.102</b>	<b>1312.11</b>
<b>10 yr</b>	<b>0.12</b>	<b>1557.005</b>
<b>25 yr</b>	<b>0.138</b>	<b>1802.132</b>

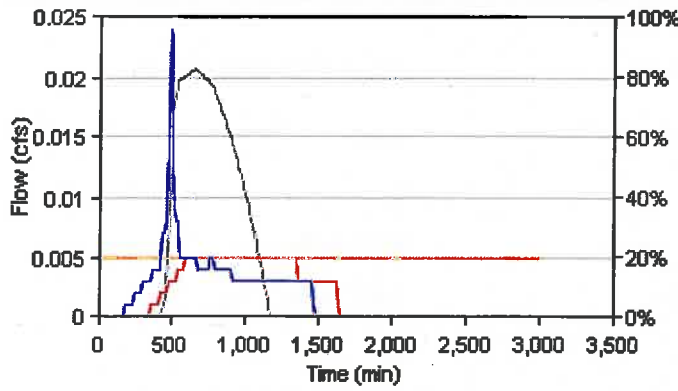
# Facility C

<b>Facility Details</b>	Facility Type	<b>Planter (Sloped)</b>
	Facility Configuration	<b>C: Infl. with RS and underdrain (Ud)</b>
	Facility Shape	<b>Sloped</b>
<b>Above Grade Storage Data</b>		
	Growing Medium Depth	<b>18 in</b>
	Surface Capacity at Depth 1	<b>58.9 cu ft</b>
	Design Infiltration Rate for Native Soil	<b>0.001 in/hr</b>
	Infiltration Capacity	<b>0.005 cfs</b>
<b>Below Grade Storage Data</b>		
	Rock Storage Depth	<b>12 in</b>
	Rock Porosity	<b>0.30 in</b>
	Storage Depth 3	<b>6.0 in</b>
<b>Facility Facts</b>	Total Facility Area Including Freeboard	<b>110.40 sq ft</b>
	Sizing Ratio	<b>1.9%</b>
<b>Pollution Reduction Results</b>	Pollution Reduction Score	<b>Pass</b>
	Overflow Volume	<b>194.608 cf</b>
	Surface Capacity Used	<b>83%</b>
	Rock Capacity Used	<b>100%</b>
<b>10 Year Results</b>	10 Year Score	<b>Fail</b>
	Overflow Volume	<b>1419.877 cf</b>
	Surface Capacity Used	<b>100%</b>
	Rock Capacity Used	<b>100%</b>

## Sloped Facility Worksheet

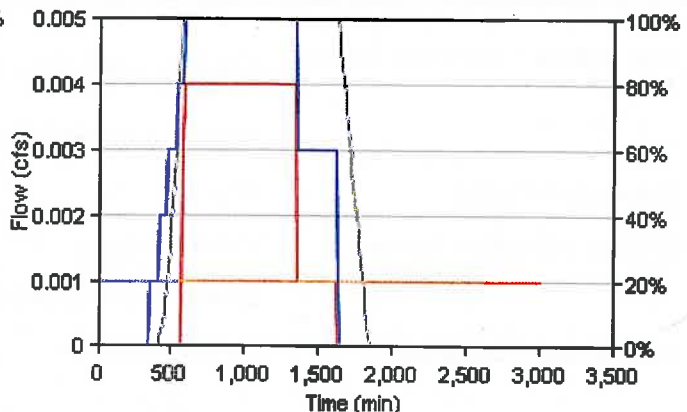
#	Segment Length (ft)	Check Dam Length (ft)	Slope, v/h (ft/ft)	Bottom Width (ft)	Right Side Slope, h/v (ft/ft)	Left Side Slope, h/v (ft/ft)	Downstream Depth (in)	Landscape Width (ft)	Rock Storage Width (ft)
1	10.90	0.50	0.0110	5.00	0.0	0.0	7.2	5.00	5.00
2	8.60	0.50	0.0110	6.50	0.0	0.0	7.2	6.50	6.50

**Pollution Reduction Event Surface Facility Modeling**



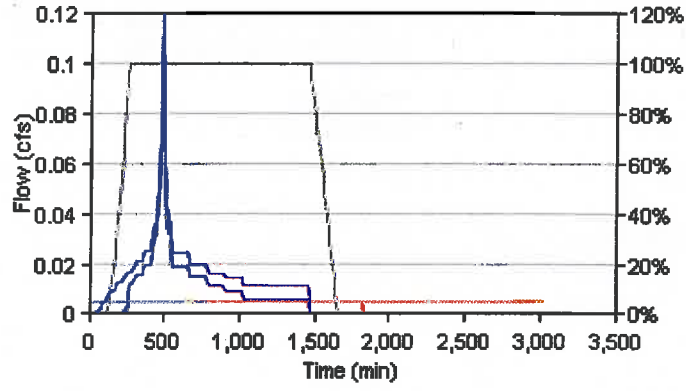
- Inflow from rain
- Total flow to below grade storage
- Flow bypassing growing medium
- Infiltration capacity
- Percent surface capacity

**Pollution Reduction Event Below Grade Modeling**



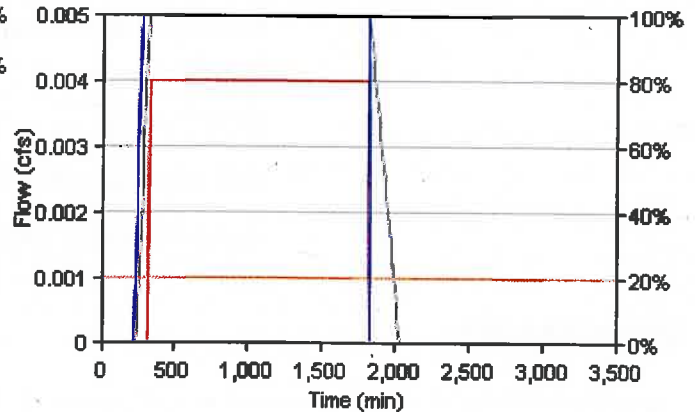
- Inflow to rock storage
- Overflow to approved discharge
- Infiltration capacity
- Percent rock capacity

**10 Year Event Surface Facility Modeling**



- Inflow from rain
- Total flow to below grade storage
- Flow bypassing growing medium
- Infiltration capacity
- Percent surface capacity

**10 Year Event Below Grade Modeling**

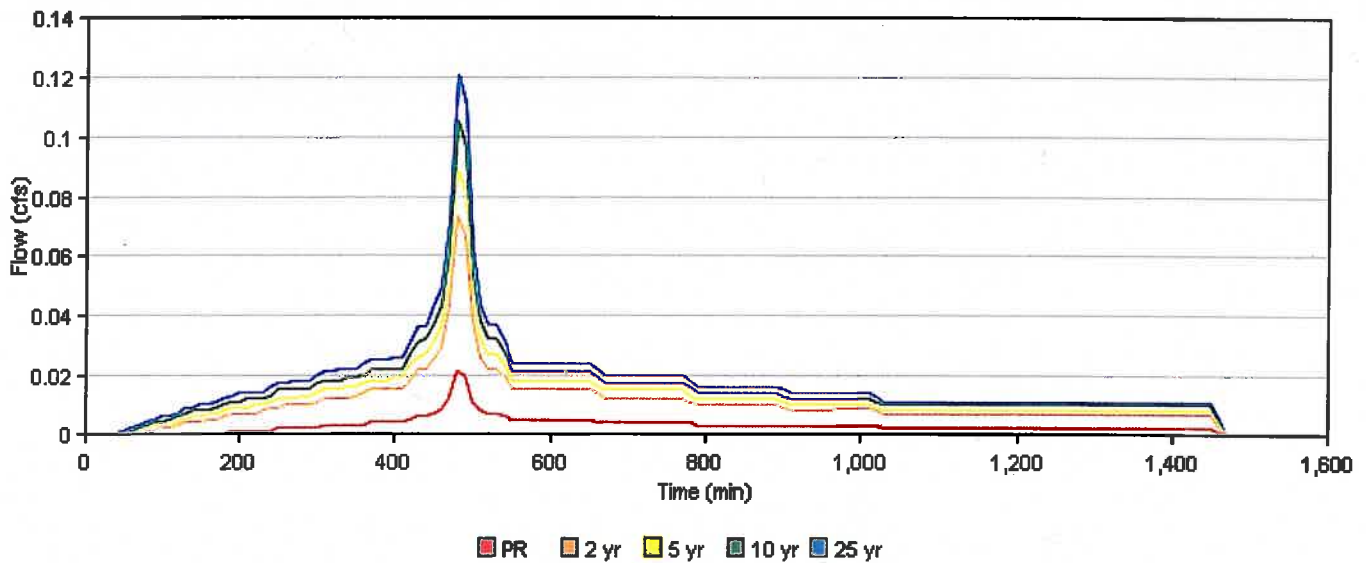


- Inflow to rock storage
- Overflow to approved discharge
- Infiltration capacity
- Percent rock capacity

## Catchment D

<b>Site Soils &amp; Infiltration Testing Data</b>	Infiltration Testing Procedure	<b>Open Pit Falling Head</b>
	Native Soil Infiltration Rate ( $I_{test}$ )	<b>1.00</b>
<b>Correction Factor</b>	$CF_{test}$	<b>2</b>
<b>Design Infiltration Rates</b>	Native Soil ( $I_{dsgn}$ )	<b>0.50 in/hr</b>
	Imported Growing Medium	<b>2.00 in/hr</b>
<b>Catchment Information</b>	Hierarchy Category	<b>2</b>
	Hierarchy Description	<b>On-site infiltration through use of approved UIC facility</b>
	Pollution Reduction Requirement	<b>Pass</b>
	10-year Storm Requirement	<b>Pass or if Fail, disposal through separate approved UIC</b>
	Flow Control Requirement	<b>Pass or if Fail, disposal through separate approved UIC</b>
	Impervious Area	<b>5150 sq ft 0.118 acre</b>
	Time of Concentration ( $T_c$ )	<b>5</b>
	Post-Development Curve Number ( $CN_{post}$ )	<b>98</b>

## SBUH Results



	Peak Rate (cfs)	Volume (cf)
PR	0.021	269.102
2 yr	0.073	931.871



<b>5 yr</b>	<b>0.089</b>	<b>1145.316</b>
<b>10 yr</b>	<b>0.105</b>	<b>1359.081</b>
<b>25 yr</b>	<b>0.121</b>	<b>1573.047</b>

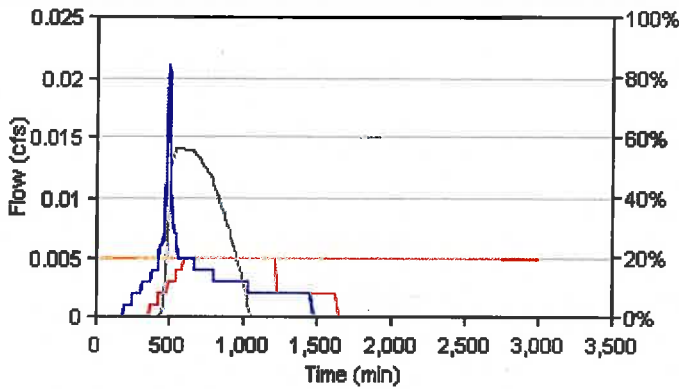
## Facility D

<b>Facility Details</b>	Facility Type	<b>Planter (Sloped)</b>
	Facility Configuration	<b>C: Infl. with RS and underdrain (Ud)</b>
	Facility Shape	<b>Sloped</b>
	<b>Above Grade Storage Data</b>	
	Growing Medium Depth	<b>18 in</b>
	Surface Capacity at Depth 1	<b>65.9 cu ft</b>
	Design Infiltration Rate for Native Soil	<b>0.001 in/hr</b>
	Infiltration Capacity	<b>0.005 cfs</b>
	<b>Below Grade Storage Data</b>	
	Rock Storage Depth	<b>12 in</b>
	Rock Porosity	<b>0.30 in</b>
	Storage Depth 3	<b>6.0 in</b>
<b>Facility Facts</b>	Total Facility Area Including Freeboard	<b>115.40 sq ft</b>
	Sizing Ratio	<b>2.2%</b>
<b>Pollution Reduction Results</b>	Pollution Reduction Score	<b>Pass</b>
	Overflow Volume	<b>164.852 cf</b>
	Surface Capacity Used	<b>57%</b>
	Rock Capacity Used	<b>100%</b>
<b>10 Year Results</b>	10 Year Score	<b>Fail</b>
	Overflow Volume	<b>1233.661 cf</b>
	Surface Capacity Used	<b>100%</b>
	Rock Capacity Used	<b>100%</b>

### Sloped Facility Worksheet

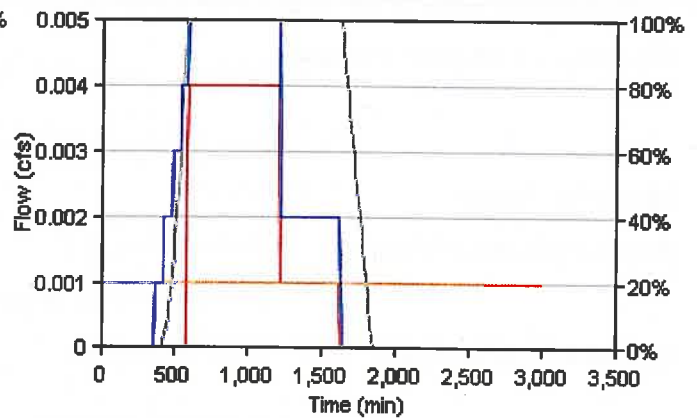
#	Segment Length (ft)	Check Dam Length (ft)	Slope, v/h (ft/ft)	Bottom Width (ft)	Right Side Slope, h/v (ft/ft)	Left Side Slope, h/v (ft/ft)	Downstream Depth (in)	Landscape Width (ft)	Rock Storage Width (ft)
1	9.40	0.50	0.0110	4.50	0.0	0.0	8.4	5.00	4.50
2	11.40	0.50	0.0110	5.50	0.0	0.0	8.4	6.00	5.00

**Pollution Reduction Event Surface Facility Modeling**



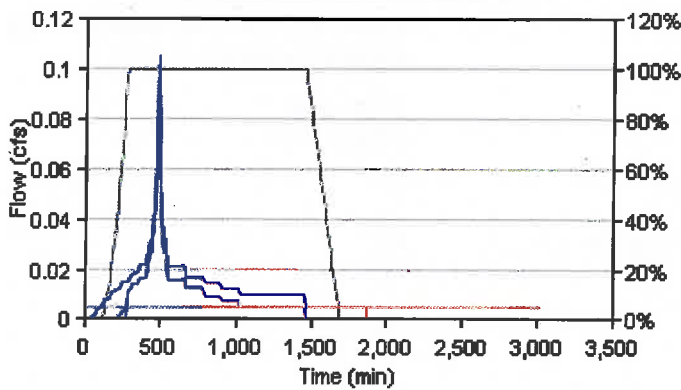
- Inflow from rain
- Total flow to below grade storage
- Percent surface capacity
- Infiltration capacity
- Flow bypassing growing medium

**Pollution Reduction Event Below Grade Modeling**



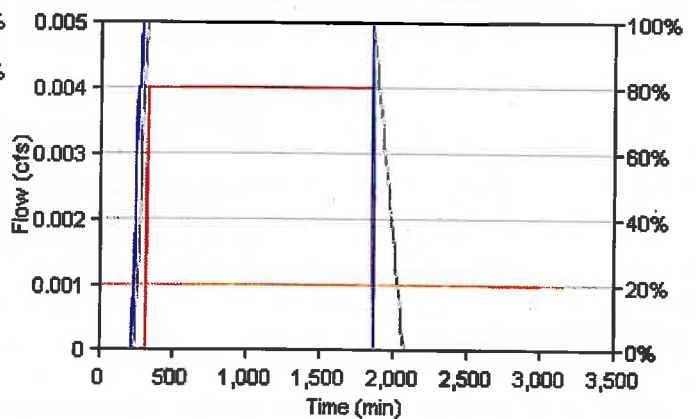
- Inflow to rock storage
- Overflow to approved discharge
- Infiltration capacity
- Percent rock capacity

**10 Year Event Surface Facility Modeling**



- Inflow from rain
- Total flow to below grade storage
- Percent surface capacity
- Infiltration capacity
- Flow bypassing growing medium

**10 Year Event Below Grade Modeling**

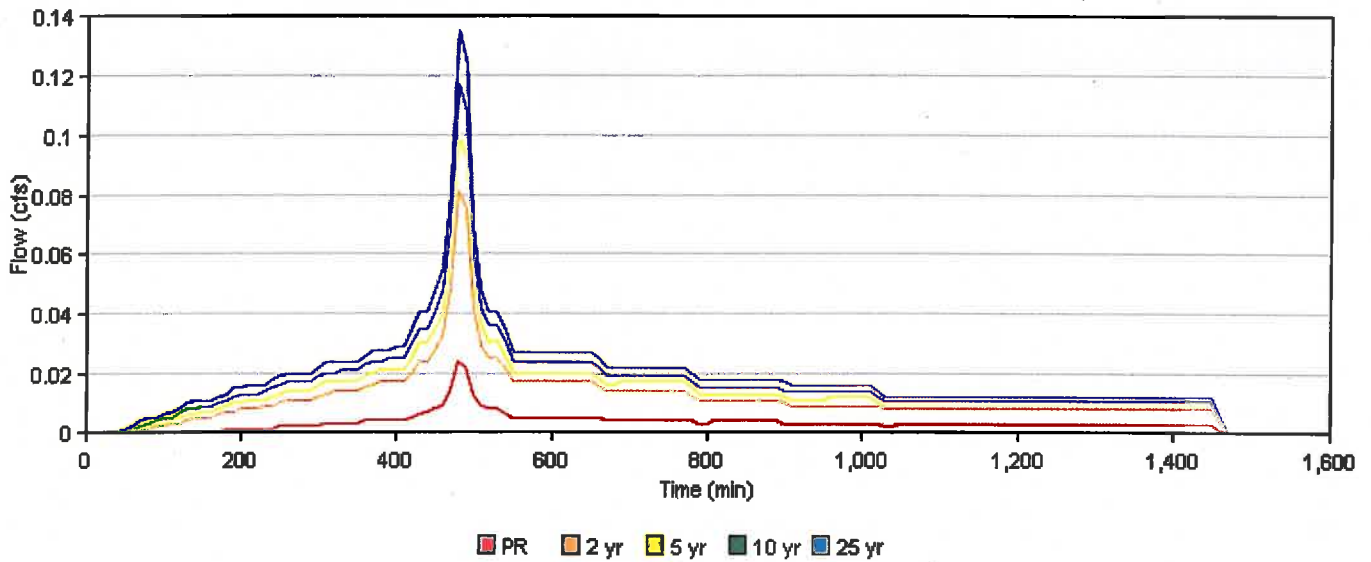


- Inflow to rock storage
- Overflow to approved discharge
- Infiltration capacity
- Percent rock capacity

# Catchment E

<b>Site Soils &amp; Infiltration Testing Data</b>	Infiltration Testing Procedure	<b>Open Pit Falling Head</b>
	Native Soil Infiltration Rate ( $I_{test}$ )	<b>1.00</b>
<b>Correction Factor</b>	$CF_{test}$	<b>2</b>
<b>Design Infiltration Rates</b>	Native Soil ( $I_{dsgn}$ )	<b>0.50 in/hr</b>
	Imported Growing Medium	<b>2.00 in/hr</b>
<b>Catchment Information</b>	Hierarchy Category	<b>2</b>
	Hierarchy Description	<b>On-site infiltration through use of approved UIC facility</b>
	Pollution Reduction Requirement	<b>Pass</b>
	10-year Storm Requirement	<b>Pass or if Fail, disposal through separate approved UIC</b>
	Flow Control Requirement	<b>Pass or if Fail, disposal through separate approved UIC</b>
	Impervious Area	<b>5750 sq ft 0.132 acre</b>
	Time of Concentration ( $T_c$ )	<b>5</b>
	Post-Development Curve Number ( $CN_{post}$ )	<b>98</b>

## SBUH Results



	Peak Rate (cfs)	Volume (cf)
PR	0.024	300.454
2 yr	0.081	1040.439

<b>5 yr</b>	0.099	1278.751
<b>10 yr</b>	0.117	1517.42
<b>25 yr</b>	0.135	1756.315

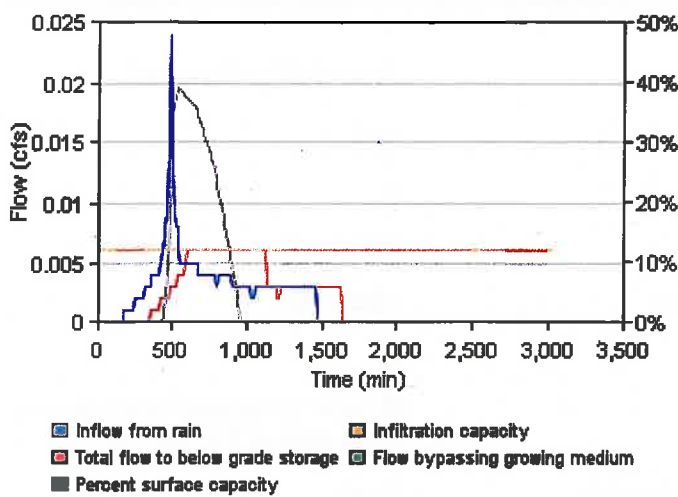
## Facility E

<b>Facility Details</b>	Facility Type	<b>Planter (Sloped)</b>
	Facility Configuration	<b>C: Infl. with RS and underdrain (Ud)</b>
	Facility Shape	<b>Sloped</b>
	<b>Above Grade Storage Data</b>	
	Growing Medium Depth	<b>18 in</b>
	Surface Capacity at Depth 1	<b>98.9 cu ft</b>
	Design Infiltration Rate for Native Soil	<b>0.001 in/hr</b>
	Infiltration Capacity	<b>0.006 cfs</b>
	<b>Below Grade Storage Data</b>	
	Rock Storage Depth	<b>12 in</b>
	Rock Porosity	<b>0.30 in</b>
	Storage Depth 3	<b>6.0 in</b>
<b>Facility Facts</b>	Total Facility Area Including Freeboard	<b>164.00 sq ft</b>
	Sizing Ratio	<b>2.9%</b>
<b>Pollution Reduction Results</b>	Pollution Reduction Score	<b>Pass</b>
	Overflow Volume	<b>174.288 cf</b>
	Surface Capacity Used	<b>39%</b>
	Rock Capacity Used	<b>100%</b>
<b>10 Year Results</b>	10 Year Score	<b>Fail</b>
	Overflow Volume	<b>1361.375 cf</b>
	Surface Capacity Used	<b>100%</b>
	Rock Capacity Used	<b>100%</b>

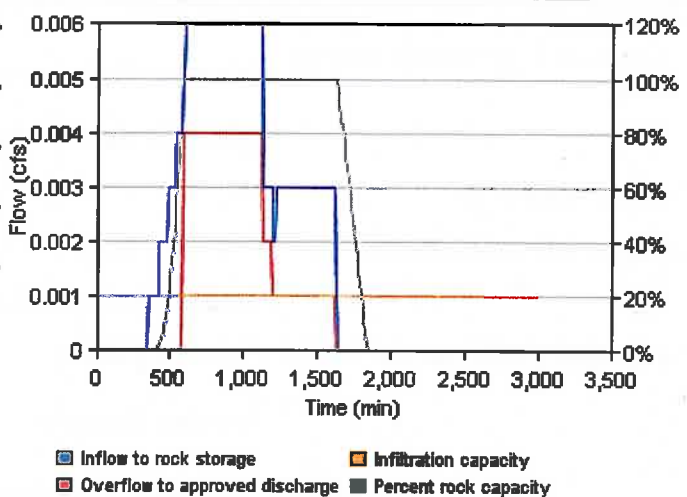
### Sloped Facility Worksheet

#	Segment Length (ft)	Check Dam Length (ft)	Slope, v/h (ft/ft)	Bottom Width (ft)	Right Side Slope, h/v (ft/ft)	Left Side Slope, h/v (ft/ft)	Downstream Depth (in)	Landscape Width (ft)	Rock Storage Width (ft)
1	6.00	0.50	0.0610	7.00	0.0	0.0	12.0	9.00	6.50
2	6.00	0.50	0.0610	7.00	0.0	0.0	12.0	9.00	6.50
3	8.00	0.50	0.0610	5.50	0.0	0.0	12.0	7.00	5.50

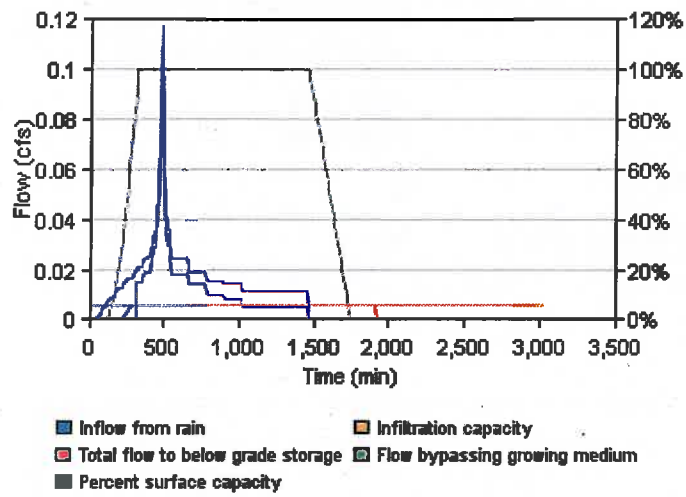
**Pollution Reduction Event Surface Facility Modeling**



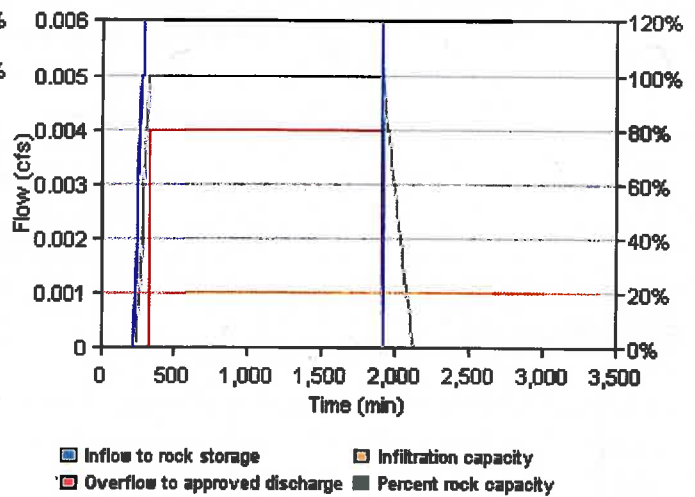
**Pollution Reduction Event Below Grade Modeling**



**10 Year Event Surface Facility Modeling**



**10 Year Event Below Grade Modeling**



# Catchment F

## Site Soils & Infiltration Testing Data

Infiltration Testing Procedure

Open Pit Falling Head

Native Soil Infiltration Rate ( $I_{test}$ )

1.00

## Correction Factor

$CF_{test}$

2

## Design Infiltration Rates

Native Soil ( $I_{dsgn}$ )

0.50 in/hr

Imported Growing Medium

2.00 in/hr

## Catchment Information

Hierarchy Category

2

Hierarchy Description

On-site infiltration through use of approved UIC facility

Pollution Reduction Requirement

Pass

10-year Storm Requirement

Pass or if Fail, disposal through separate approved UIC

Flow Control Requirement

Pass or if Fail, disposal through separate approved UIC

Impervious Area

4650 sq ft  
0.107 acre

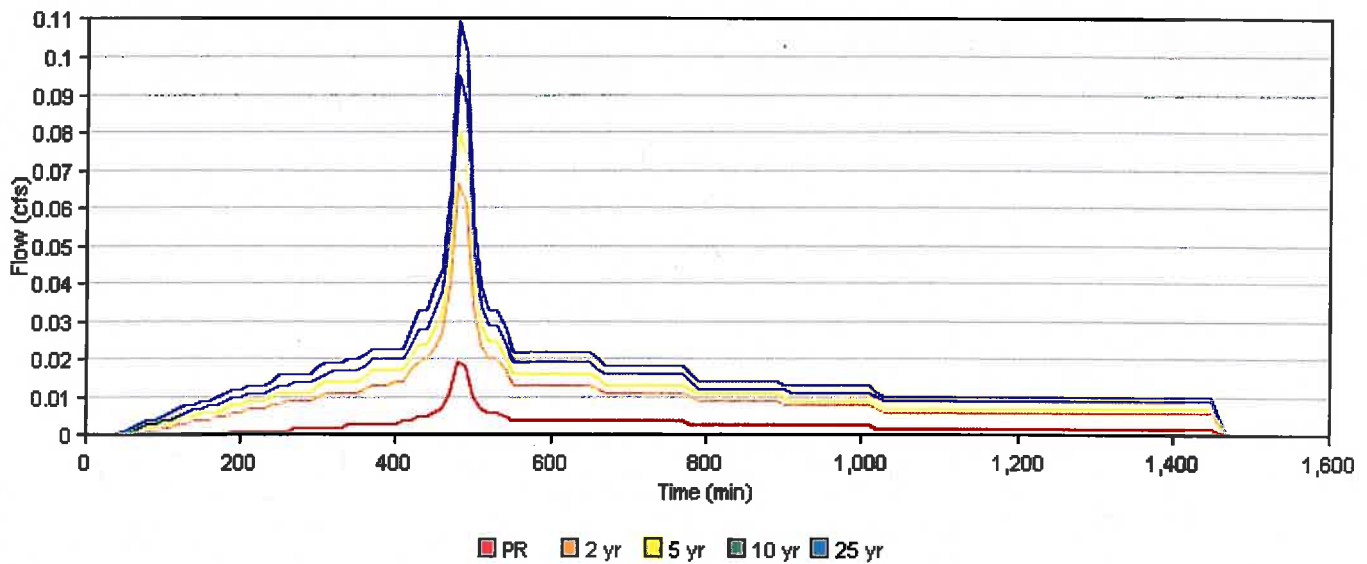
Time of Concentration ( $T_c$ )

5

Post-Development Curve Number ( $CN_{post}$ )

98

## SBUH Results



	Peak Rate (cfs)	Volume (cf)
PR	0.019	242.976
2 yr	0.066	841.398



<b>5 yr</b>	0.08	1034.121
<b>10 yr</b>	0.095	1227.131
<b>25 yr</b>	0.109	1420.324

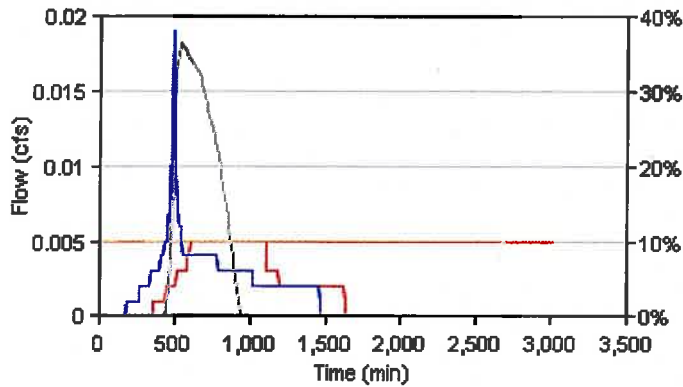
## Facility F

<b>Facility Details</b>	Facility Type	<b>Planter (Sloped)</b>
	Facility Configuration	<b>C: Infl. with RS and underdrain (Ud)</b>
	Facility Shape	<b>Sloped</b>
	<b>Above Grade Storage Data</b>	
	Growing Medium Depth	<b>18 in</b>
	Surface Capacity at Depth 1	<b>83.7 cu ft</b>
	Design Infiltration Rate for Native Soil	<b>0.001 in/hr</b>
	Infiltration Capacity	<b>0.005 cfs</b>
	<b>Below Grade Storage Data</b>	
	Rock Storage Depth	<b>12 in</b>
	Rock Porosity	<b>0.30 in</b>
	Storage Depth 3	<b>6.0 in</b>
<b>Facility Facts</b>	Total Facility Area Including Freeboard	<b>113.40 sq ft</b>
	Sizing Ratio	<b>2.4%</b>
<b>Pollution Reduction Results</b>	Pollution Reduction Score	<b>Pass</b>
	Overflow Volume	<b>142.997 cf</b>
	Surface Capacity Used	<b>36%</b>
	Rock Capacity Used	<b>100%</b>
<b>10 Year Results</b>	10 Year Score	<b>Fail</b>
	Overflow Volume	<b>1102.865 cf</b>
	Surface Capacity Used	<b>100%</b>
	Rock Capacity Used	<b>100%</b>

### Sloped Facility Worksheet

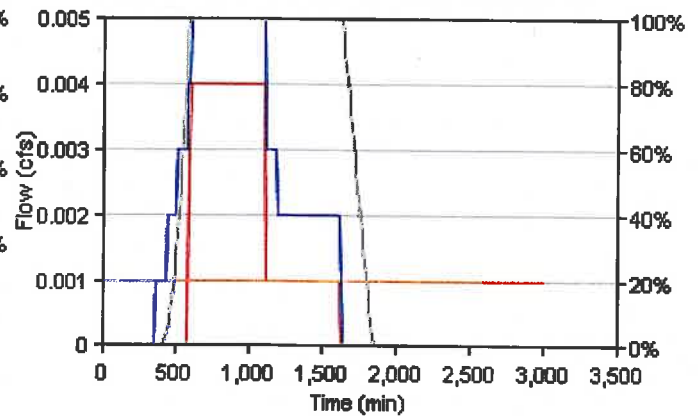
#	Segment Length (ft)	Check Dam Length (ft)	Slope, v/h (ft/ft)	Bottom Width (ft)	Right Side Slope, h/v (ft/ft)	Left Side Slope, h/v (ft/ft)	Downstream Depth (in)	Landscape Width (ft)	Rock Storage Width (ft)
1	8.20	0.50	0.0580	6.50	0.0	0.0	10.8	7.00	6.00
2	8.00	0.50	0.0580	6.50	0.0	0.0	14.4	7.00	6.00

Pollution Reduction Event Surface Facility Modeling



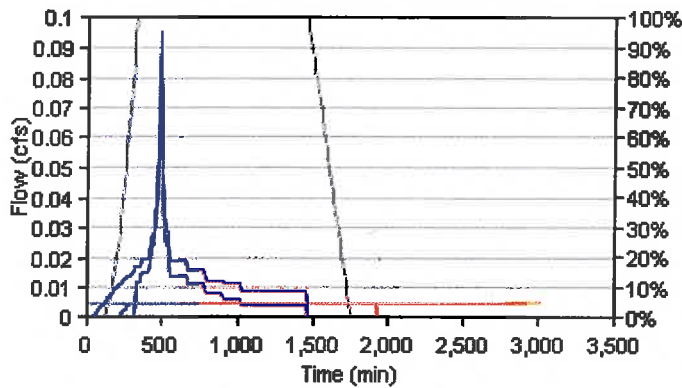
- Inflow from rain
- Total flow to below grade storage
- Percent surface capacity
- Infiltration capacity
- Flow bypassing growing medium

Pollution Reduction Event Below Grade Modeling



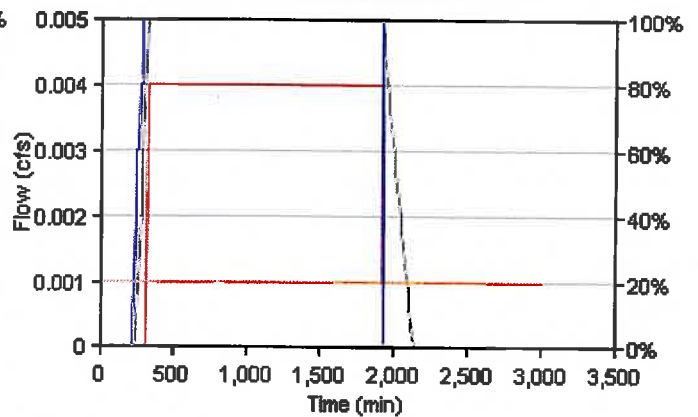
- Inflow to rock storage
- Overflow to approved discharge
- Percent rock capacity
- Infiltration capacity

10 Year Event Surface Facility Modeling



- Inflow from rain
- Total flow to below grade storage
- Percent surface capacity
- Infiltration capacity
- Flow bypassing growing medium

10 Year Event Below Grade Modeling



- Inflow to rock storage
- Overflow to approved discharge
- Percent rock capacity
- Infiltration capacity

