



LAND USE PRE-APPLICATION CONFERENCE

Thursday, April 6, 2017

City Hall
22500 Salamo Road

Willamette Conference Room

11:00 am Proposed 6-foot high security fencing in several locations on the property.

Applicant: Tim Woodley, West Linn – Wilsonville School District

Subject Property Address: 4515 Cedaroak Drive

Neighborhood Assn: Robinwood

Planner: Darren Wyss

Project #: PA-17-12





PRE-APPLICATION CONFERENCE

THIS SECTION FOR STAFF COMPLETION		
CONFERENCE DATE:	4-6-17	TIME: 11:00
		PROJECT #: PA-17-12
STAFF CONTACT:	Darren Wyss	FEE: 350-

Pre-application conferences occur on the first and third Thursdays of each month. In order to be scheduled for a conference, this form including property owner's signature, the pre-application fee, and accompanying materials must be submitted at least 14 days in advance of the conference date. Twenty-four hour notice is required to reschedule.

Address of Subject Property (or map/tax lot): 4515 S. Cedaroak Dr. West Linn, OR 97068

Brief Description of Proposal: To install 6-foot high security fencing in several locations on the property.

Applicant's Name: Tim Woodley, West Linn-Wilsonville School District

Mailing Address: 2755 SW Borland Rd., Tualatin, OR 97062

Phone No: (503) 673-7976

Email Address: woodleyt@wlwv.k12.or.us

Please attach additional materials relating to your proposal including a site plan on paper up to 11 x 17 inches in size depicting the following items:

- North arrow
- Scale
- Property dimensions
- Streets abutting the property
- Conceptual layout, design and/or building elevations
- Easements (access, utility, all others)
- Access to and from the site, if applicable
- Location of existing trees, highly recommend a tree survey
- Location of creeks and/or wetlands, highly recommend a wetland delineation
- Location of existing utilities (water, sewer, etc.)

Please list any questions or issues that you may have for city staff regarding your proposal: Development review process and the applicable approval criteria.

By my signature below, I grant city staff right of entry onto the subject property in order to prepare for the pre-application conference.

Tim Woodley
Property owner's signature

3.9.17
Date

Property owner's mailing address (if different from above)

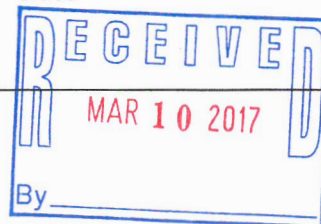

MEMORANDUM

TO: Peter Spir
FROM: Keith Liden
RE: Pre-application meeting for Cedaroak Primary School
DATE: March 10, 2016

The West Linn-Wilsonville School District would like to schedule the pre-application meeting for April 6, 2017 to discuss the addition of some security fencing on the school property. Key topics the district would like to cover include:

- Class I Design Review approval process and criteria; and
- Application submittal requirements.



LEGEND

- 1 steel picket fence
- 2 steel picket fence w/ columns
alt: solid brick wall
- 3 steel welded wire fence
- existing fence to remain
- proposed fence
- ▲ proposed 4ft wide gate *
- ▲ proposed 8ft wide slide gate *
- new planting area

* gate locations, number and size are to be determined based on occupancy and egress requirements





PRECAST CONCRETE
COLUMN

STEEL PICKET FENCE

STEEL PICKET GATE

STEEL PICKET FENCE WITH CONCRETE COLUMNS



EXISTING COLUMN



CUSTOM COLOR PALETTE

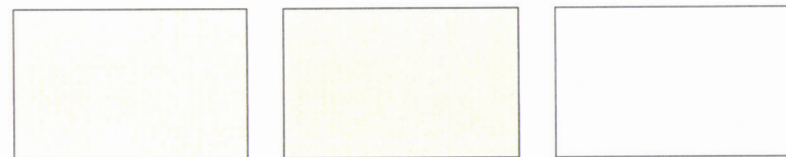

BASIS OF DESIGN: AMERISTAR AEGIS II

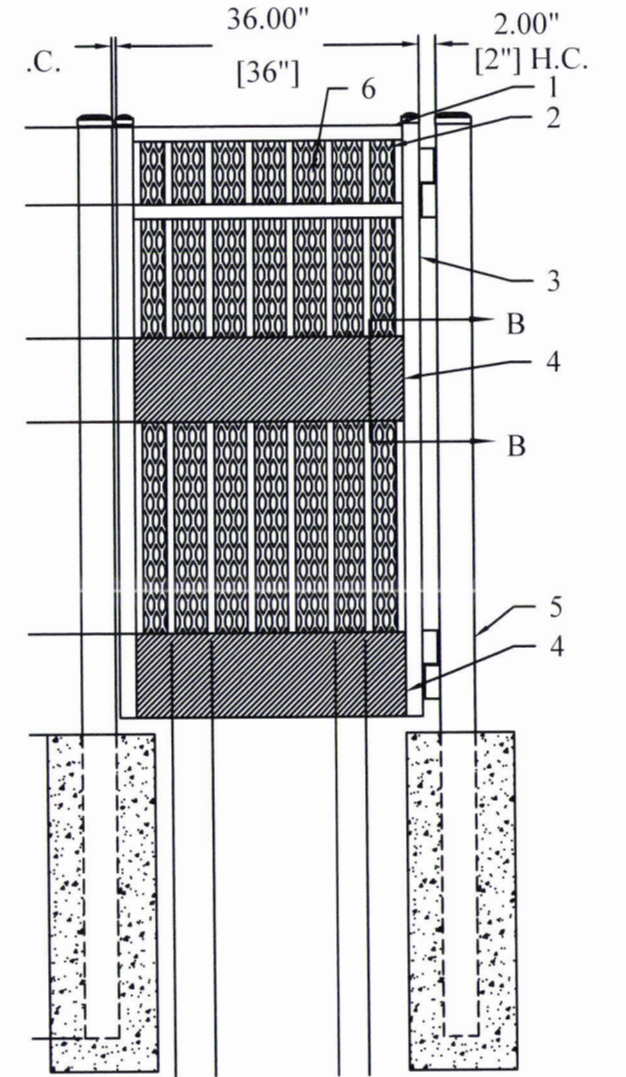

GATE WITH PANIC HARDWARE



STEEL PICKET FENCE WITH COLUMNS | BRICK WALL



WELDED WIRE MESH FENCE



BASIS OF DESIGN: WIREWORKS PLUS

STEEL WELDED WIRE FENCE



STEEL PICKET FENCE

STEEL PICKET GATE

ROLLING STEEL
PICKET GATE

PLAY AREA - STEEL PICKET FENCE WITH GATES

WALKER | MACY