



# CITY OF West Linn

22500 Salamo Road  
West Linn, OR 97068

## STAFF REPORT FOR THE PLANNING COMMISSION

**FILE NUMBER:** CUP-15-03, DR-15-17, VAR-15-01/02/03

**HEARING DATE:** March 16, 2016

**REQUEST:** A Conditional Use Permit to replace the Sunset Primary School at 2351 Oxford Street, requiring a variance to parking location, sign area, and bicycle parking location.

**APPROVAL CRITERIA:** Community Development Code (CDC) Chapter 11; Chapter 38; Chapter 41; Chapter 42; Chapter 44; Chapter 46; Chapter 48; Chapter 52; Chapter 54; Chapter 55; Chapter 60; Chapter 75; Chapter 92; Chapter 96; and Chapter 99.

**STAFF REPORT PREPARED BY:** Darren Wyss, Associate Planner

---

Planning Manager's Initials QJB Development Review Engineer's Initials KQL

---

### TABLE OF CONTENTS

**STAFF ANALYSIS AND RECOMMENDATION**

GENERAL INFORMATION ..... 2

EXECUTIVE SUMMARY ..... 3-4

PUBLIC COMMENTS.....4

RECOMMENDATION..... 5-6

ADDENDUM ..... 7-52

**EXHIBITS**

PC-1 AFFIDAVIT AND NOTICE PACKET ..... 53-58

PC-2 COMPLETENESS LETTER..... 59-60

PC-3 APPLICANT'S SUBMITTAL ..... 61-225

PC-4 PUBLIC COMMENTS..... 226-235

PC-5 APPLICANT MEMORANDUM ADDRESSING CDC 46.120.....236-238

PC-6 BITTNER STREET SANITARY SEWER PROPORTIONAL SHARE..... 239-240

## GENERAL INFORMATION

**OWNER:** West Linn-Wilsonville School District  
2755 SW Borland Road  
Tualatin, OR 97062  
Contact: Tim Woodley

**APPLICANT:** West Linn-Wilsonville School District  
2755 SW Borland Road  
Tualatin, OR 97062  
Contact: Tim Woodley

**CONSULTANT:** Keith Liden  
319 SW Washington Street, Suite 914  
Portland, OR 97204  
Contact: Keith Liden

**SITE LOCATION:** 2351 Oxford Street

**LEGAL DESCRIPTION:** Clackamas County Assessor's Map 2S-1E-25DC, Taxlots 3700, 5800, 6100, 6200, and 6300

**SITE SIZE:** 6.19 acres

**ZONING:** R-10, Single-Family Residential Detached and Attached.

**COMP PLAN DESIGNATION:** Low-Density Residential

**120-DAY PERIOD:** This application became complete on February 1, 2016. The 120-day maximum application-processing period ends on May 31, 2016.

**PUBLIC NOTICE:** Public notice was mailed to the all neighborhood associations and affected property owners on February 25, 2016. The property was posted with a notice sign on March 2, 2016. The notice was published in the West Linn Tidings on March 3, 2016. The notice requirements of CDC Chapter 99 have been met. In addition, the application was posted on the City's website December 2, 2015.

## EXECUTIVE SUMMARY

**Site Conditions:** The proposed development site is located in the Sunset Neighborhood and currently contains the existing 54,000 square foot Sunset Primary School and associated driveway, parking, and play areas. The site is zoned R-10, is 6.19 acres, “L” shaped and bordered by Oxford and Bittner Streets, Sunset Park, and residential development. The site is relatively flat and contains a number of significant trees in the southeast portion. Access to the site is provided by Oxford and Bittner Streets, as well as two pedestrian pathways that connect through the residential areas north to Oregon City Boulevard and east to Oregon City Loop.

**Project Description:** The West Linn-Wilsonville School District is requesting approval for a conditional use permit, design review, and three variances for the purpose of constructing a new Sunset Primary School on the site containing the existing school. The variances are for the following:

- Class II Variance to allow on-site parking spaces to be located beyond the 200-foot maximum distance to the building entrance as required in CDC Section 46.070.
- Class II Variance to allow on-site bike parking spaces to be located beyond the 50-foot maximum distance to the building entrance as required in CDC Section 46.150.
- Class II Variance to allow a wall sign of approximately 42 square feet where a maximum of 18 feet is required in CDC Section 52.300.

The proposed site improvements include:

- Replacing the existing school building with a new 61,680 square foot building
- New on-site circulation and parking
- New sports field and play areas

The project will be conducted in two construction phases to allow the school to operate continuously on the site. The first phase will include construction of the new school building and playground in the general location of the existing playground and sports field. The second phase will commence once the new school building is complete. The second phase includes demolition of the existing school building and constructing a new sports field and parking in that location.

**Surrounding Land Use and Zoning:** The site is located zoned R-10 and located in the Sunset Neighborhood. Adjacent land uses and zoning include:

Direction From Site	Zoning	Land Use
North/Northwest	R-10	Single-family residences
East	R-10	Single-family residences
South/Southeast	R-10/R-7/R-5	Single-family residences and Sunset Park

**Applicable Community Development Code Approval Criteria:**

- Chapter 11, Single-Family Residential Detached, R-10;
- Chapter 38, Additional Yard Area Required, Exceptions to Yard Requirements, Storage in Yards, Projections into Yards;
- Chapter 41, Building Height, Structures on Steep Slopes, Exceptions;
- Chapter 42, Clear Vision Areas;
- Chapter 44, Fences;
- Chapter 46, Off-Street Parking, Loading and Reservoir Areas;
- Chapter 48, Access, Egress and Circulation;
- Chapter 52, Signs;
- Chapter 54, Landscaping;
- Chapter 55, Design Review;
- Chapter 60 Conditional Uses;
- Chapter 75, Variances and Special Waivers;
- Chapter 92, Required Improvements;
- Chapter 96, Street Improvement Construction; and
- Chapter 99, Procedures for Decision Making: Quasi-Judicial.

**Public comments:**

As of the publication date of this report, staff has received three submittals from neighborhood residents, two in favor of the proposal and one in opposition. Tualatin Valley Fire & Rescue dated December 9, 2015. All comments can be found in Exhibit PC-4.

## RECOMMENDATION

Staff recommends approval of application CUP-15-03/DR-15-17/VAR-15-01/02/03, based on: 1) the findings submitted by the applicant, which are incorporated by this reference, 2) supplementary staff findings included in the Addendum below, and 3) the addition of conditions of approval below. With these findings, the applicable approval criteria are met. The conditions are as follows:

1. **Site Plans.** With the exception of modifications required by these conditions, the project shall substantially conform to all Tentative Plan Sheets.
2. **Engineering Standards.** All public improvements and facilities associated with the approved site design, including but not limited to street improvements, driveway approaches, curb cuts, utilities, grading, onsite and offsite stormwater, street lighting, easements, easement locations, and connections for future extension of utilities are subject to the City Engineer's review, modification, and approval. These must be designed, constructed, and completed prior to the issuance of the final building certificate of occupancy.
3. **Street Improvements.** The applicant shall complete full street improvements, including pavement improvements, curbs, planter strips, street trees, street lights, sidewalks, pedestrian crossings, and street storm drainage for those portions of Oxford Street and Bitter Street abutting the subject properties, per Staff Findings 143 and 144. Construction of the half street improvements and storm drainage improvements on the west side of Bittner Street and the south side of Oxford Street shall be reimbursed by the City of West Linn.
4. **Overhead Utilities.** All existing overhead utilities and associated services must be removed and placed underground per Staff Finding 99. This must be completed prior to the issuance of the final building certificate of occupancy.
5. **Carpool Spaces.** The applicant shall identify four parking spaces closest to the building entrance for carpools, per Staff Finding 15, and provide signage reading *"Reserved – Carpool/Vanpool Before 9:00 a.m."*
6. **Parking Lot Design.** The applicant shall reconfigure the parking areas to meet group of 12 parking design requirements per Staff Finding 25, while maintaining a total of 88 total parking spaces. The new configuration must also meet the 50 percent maximum compact space requirements.
7. **Curb Cuts.** The applicant shall redesign the three vehicle accessways to comply with the maximum curb cut requirements of 36 feet, per Staff Finding 43, and to also meet West Linn Public Works Standards.

8. **No Parking Signs.** The applicant shall install signs, per Staff Finding 40, reading “No Parking – Fire Lane” on both sides of the fire access drives. The signs shall be 12 inches wide by 18 inches high and shall have red letters on a white reflective background. The signs shall be installed with a clear space above grade level of 7 feet.
9. **Tree Protection.** The applicant shall provide appropriate root zone protections, per Staff Finding 70, for the 14 significant trees that are proposed to be retained and identified in the Arborist Report as needing monitoring. The applicant shall consult with both the project arborist and the City arborist to utilize the most effective measures. This includes the required protection fencing.
10. **Tree Conservation Easement.** The applicant shall provide a tree conservation easement, per Staff Finding 70, for all significant trees that are retained on site and not already protected by required setbacks. The easement shall extend outwards to the tree dripline plus 10 feet. The easement shall include a legal description and a map of the area. The easement shall be recorded with the County and a copy of the recorded easement shall be provided to the City of West Linn prior to the issuance of the final building certificate of occupancy.
11. **Fire Flow.** The applicant shall perform a fire flow test, per Staff Finding 91, and submit a letter from Tualatin Valley Fire and Rescue showing adequate fire flow is present prior to the issuance of the final building certificate of occupancy.
12. **Sanitary Sewer Improvement.** The applicant shall install approximately 450 feet of sewer main with the associated manholes and sewer laterals along Bittner Street to the connection point on Long Street in accordance with Exhibit PC-6 and Staff Finding 92. Construction of approximately 175 feet of sewer main, associated manholes, and the 12 sewer laterals will be reimbursed by the City pursuant to Exhibit PC-6.

**ADDENDUM**  
**PLANNING COMMISSION STAFF REPORT**  
March 16, 2016

**STAFF EVALUATION OF THE PROPOSAL'S COMPLIANCE  
WITH APPLICABLE CODE CRITERIA**

***I. CHAPTER 11, SINGLE-FAMILY RESIDENTIAL DETACHED, R-10***

*11.020 PROCEDURES AND APPROVAL PROCESS*

*(...)*

*C. A conditional use (CDC [11.060](#)) is a use the approval of which is discretionary with the Planning Commission. The approval process and criteria for approval are set forth in Chapter [60](#) CDC, Conditional Uses. If a use is not listed as a conditional use, it may be held to be a similar unlisted use under the provisions of Chapter [80](#) CDC.*

*(...)*

**Staff Finding 1: The application is for a conditional use, design review, and three variances. The Planning Commission will hold a public hearing to make a decision on the joint application. This criterion is met.**

*11.060 CONDITIONAL USES*

*The following are conditional uses which may be allowed in this zoning district subject to the provisions of Chapter [60](#) CDC, Conditional Uses.*

*(...)*

*7. Schools*

*(...)*

**Staff Finding 2: The new Sunset School replaces the existing school in a new location on the subject property. The applicant has identified that the site of the proposed new Sunset Primary School is located entirely within the R-10 zoning district, which allows schools as a conditional use. Subject to approval by the Planning Commission, this criterion is met.**

*(...)*

*11.080 DIMENSIONAL REQUIREMENTS, CONDITIONAL USES*

*Except as may otherwise be established by this code, the appropriate lot or parcel size for a conditional use shall be determined by the approval authority at the time of consideration of the application based upon the criteria set forth in CDC [60.070\(A\)](#) and (B).*

**Staff Finding 3: The applicant has proposed a site design for the new Sunset Primary School that uses the site as efficiently as possible, while also providing the required improvements**

and accommodating the standard amenities of a primary school. These include parking areas and landscaping, fire access aisles, pedestrian and bicycle facilities, stormwater facilities, play fields and playgrounds, and the retention of significant trees. This criterion is met.

## **II. CHAPTER 38, ADDITIONAL YARD AREA REQUIRED, EXCEPTIONS TO YARD REQUIREMENTS, STORAGE IN YARDS, PROJECTIONS INTO YARDS**

### *38.030 SETBACK FROM STREET CENTERLINE REQUIRED*

A. *To assure improved light, air, and sight distance and to protect the public health, safety and welfare, a setback in addition to the yard requirements of the zone may be required where the right-of-way is inadequate. A determination shall be made based on the street standards contained in CDC 85.200(A).*

B. *The minimum yard requirement shall be increased to provide for street widening in the event a yard abuts a street having a right-of-way width less than required by its functional classification on the City's Comprehensive Plan Map, and in such case the setback shall be not less than the setback required by the zone plus one-half of the projected road width as required under CDC 85.200(A); however*

C. *The minimum distance from the wall of any structure to the centerline of an abutting street shall not be less than 25 feet plus the yard required by the zone. This provision shall not apply to rights-of-way of 50 feet or greater in width.*

**Staff Finding 4: The subject property is bordered by streets with two different classifications; Neighborhood Route and Local Residential. The cross-section design for a Neighborhood Route with Parking requires 60 feet of right-of-way. The cross-section design for a local street with parking on both sides, 32 foot Local Residential, requires 56 feet of right-of-way. The existing right-of-way width along the frontage of the subject property is 60 feet and adequate to accommodate the new street design. These criteria are met.**

## **III. CHAPTER 41, BUILDING HEIGHT, STRUCTURES ON STEEP SLOPES, EXCEPTIONS**

### *41.005 DETERMINING HEIGHT OF BUILDING*

A. *For all zoning districts, building height shall be the vertical distance above a reference datum measured to the highest point of a flat roof or to the deck line of a mansard roof or to the highest gable, ridgeline or peak of a pitched or hipped roof, not including projections above roofs such as cupolas, towers, etc. The reference datum shall be selected by either of the following, whichever yields a greater height of building.*

1. *For relatively flat sites where there is less than a 10-foot difference in grade between the front and rear of the building, the height of the building shall be measured from grade five feet out from the exterior wall at the front of the building; or*  
(...)

**Staff Finding 5: The applicant proposes a building location that has a seven foot difference in grade between the front and rear of the building. The proposed building height**



measurements have been made based on the grade of the site at five feet out from the exterior wall at the front of the building. These criteria are met.

*41.030 PROJECTIONS NOT USED FOR HUMAN HABITATION*

*Projections such as chimneys, spires, domes, elevator shaft housings, towers, aerials, flag poles, and other similar objects not used for human occupancy are not subject to the building height limitations of this code.*

*41.040 PLACES OF WORSHIP OR GOVERNMENT BUILDINGS*

*The height of a place of worship or governmental building may be built to a maximum height of 50 feet provided:*

- A. The total floor area of the building does not exceed one and one-half times the area of the site;*
- B. The yard dimensions in each case are equal to at least two-thirds of the building height of the principal structure; and*
- C. The approval of this exception is a part of the approval of the conditional use allowed under Chapter 60 CDC.*

**Staff Finding 6: The applicant proposes a building that has a maximum height of 32 feet at top of parapet, measured from the grade five feet out from the exterior wall at the front of the building. The proposed building height is below the maximum height of 35 feet allowed in the R-10 zoning district. HVAC equipment will be located on the roof and screened. The top of the screen will be 40 feet as measured from five feet out from the exterior wall at the front of the building. The HVAC and screening are not used for human occupancy, thus not subject to building height limitations. With that said, since a school is a government building per CDC 60.100, the proposed building could be 50 feet in height as the building design meets these exception standards as shown in the applicant submittal. These criteria are met.**

**IV. CHAPTER 42, CLEAR VISION AREAS**

*42.020 CLEAR VISION AREAS REQUIRED, USES PROHIBITED*

- A. A clear vision area shall be maintained on the corners of all property adjacent to an intersection as provided by CDC 42.040 and 42.050.*
- B. A clear vision area shall contain no planting, fence, wall, structure or temporary or permanent obstruction (except for an occasional utility pole or tree) exceeding three feet in height, measured from the top of the curb, or, where no curb exists, from the street centerline grade, except that trees exceeding this height may be located in this area, provided all branches below eight feet are removed.*

**Staff Finding 7: The subject property abuts neither a street intersection nor property corner that requires clear vision areas. However, the proposal has three street and accessway intersections that have only street trees proposed to be located within the clear vision areas. The street trees will be pruned to meet the eight foot requirement. These criteria are met.**

*42.040 COMPUTATION; STREET AND ACCESSWAY 24 FEET OR MORE IN WIDTH*

*The clear vision area for all street intersections and street and accessway intersections (accessways having 24 feet or more in width) shall be that triangular area formed by the right-of-way or property lines along such lots and a straight line joining the right-of-way or property line at points which are 30 feet distant from the intersection of the right-of-way line and measured along such lines.*

**Staff Finding 8: The subject property abuts neither a street intersection nor property corner that requires clear vision areas. However, the proposal has three 24 foot wide, street and accessway intersections that have only street trees and lawn area (no shrubs, walls, or fences) proposed to be located within the clear vision areas. The street trees will be occasionally pruned to maintain the eight foot requirement. These criteria are met.**

**V. CHAPTER 44, FENCES**

*44.020 SIGHT-OBSCURING FENCE; SETBACK AND HEIGHT LIMITATIONS*

*A. A sight- or non-sight-obscuring fence may be located on the property line or in a yard setback area subject to the following:*

*(...)*

*e. A required side yard area which does not abut a street or a rear yard and it does not exceed six feet.*

**Staff Finding 9: The applicant proposes a six-foot tall, galvanized chain link fence on the west, north, and east property lines. None of these property lines abut a street. These criteria are met.**

*44.030 SCREENING OF OUTDOOR STORAGE*

*A. All service, repair, and storage activities carried on in connection with any commercial, business or industrial activity and not conducted within an enclosed building shall be screened from view of all adjacent properties and adjacent streets by a sight-obscuring fence.*

*B. The sight-obscuring fence shall be in accordance with provisions of Chapter 42 CDC, Clear Vision Areas, and shall be subject to the provisions of Chapter 55 CDC, Design Review.*

**Staff Finding 10: The applicant proposes no permanent outside storage activities, but an enclosed refuse/recycling area will be provided and screened from view. These criteria are met.**

*44.040 LANDSCAPING*

*Landscaping which is located on the fence line and which impairs sight vision shall not be located within the clear vision area as provided in Chapter 42 CDC.*

*44.050 STANDARDS FOR CONSTRUCTION*

*A. The structural side of the fence shall face the owner's property; and*

B. *The sides of the fence abutting adjoining properties and the street shall be maintained.*

**Staff Finding 11: No fences are proposed within required clear vision areas. The fence will be constructed with the structural side facing the subject property and both sides of the fence will be maintained. These criteria are met.**

## **VI. CHAPTER 46, OFF-STREET PARKING, LOADING AND RESERVOIR AREAS**

### *46.070 MAXIMUM DISTANCE ALLOWED BETWEEN PARKING AREA AND USE*

A. *Off-street parking spaces for single- and two-family dwellings shall be located on the same lot with the dwelling.*

B. *Off-street parking spaces for uses not listed in subsection A of this section shall be located not farther than 200 feet from an entryway to the building or use they are required to serve, measured in a straight line from the building, with the following exceptions:*

*(...)*

3. *Employee parking areas for carpools and vanpools shall be located closer to the entryway to the building than general employee parking.*

*(...)*

5. *All disabled parking shall be placed closest to building entrances than all other parking. Appropriate ADA curb cuts and ramps to go from the parking lot to the ADA-accessible entrance shall be provided unless exempted by ADA code.*

**Staff Finding 12: The applicant proposes a Class II Variance to allow parking spaces more than 200 feet from an entryway to the new school building. Please see Staff Findings 128 to 134. Disabled parking spaces are proposed to be placed closest to the new school building entrances than all other parking. The proposal requires four carpool spaces. Refer to Finding 15 for locational requirements. Subject to approval of the requested variance, these criteria are met.**

### *46.080 COMPUTATION OF REQUIRED PARKING SPACES AND LOADING AREA*

*(...)*

B. *To calculate building square footage as a basis for determining how many parking spaces are needed, the area measured shall be gross floor area under the roof measured from the faces of the structure, including all habitable floors and excluding only space devoted to covered off-street parking or loading.*

C. *Where employees are specified, the employees counted are the persons who work on the premises including proprietors, executives, professional people, production, sales, and distribution employees, during the largest shift.*

D. *Fractional space requirements shall be counted as a whole space.*

E. *On-street parking along the immediate property frontage(s) may be counted toward the minimum parking requirement with approval from the City Engineer.*

*(...)*

**Staff Finding 13:** The total habitable floor space of the proposed new school building is 61,680 sq. ft. Maximum staff levels at the proposed new school building is 35 employees. The proposal does not require off-street parking to count towards minimum requirements and all fractional space calculations have been counted as a whole space. These criteria are met.

*46.090 MINIMUM PARKING SPACE REQUIREMENTS*

(...)

*B. Public and semi-public buildings/uses.*

(...)

*6. Primary school, middle school, or equivalent private or parochial school.*

*- One space for every employee, plus one space for each 1,000 square feet of floor area.*

**Staff Finding 14:** Proposed maximum staff level is 35 employees, which equates to 35 required parking spaces for employees. The calculation for required parking spaces bases on floor area:  $61,680/1,000 = 61.68 = 62$  spaces. Total number of required parking spaces for the proposal is 97 (35 + 62). The applicant proposes 88 spaces by requesting an exception through CDC 55.170.B, which allows for a reduction of 10% of the required parking. Please refer to Staff Finding 107. These criteria are met.

(...)

*F. Maximum parking. Parking spaces (except for single-family and two-family residential uses) shall not exceed the minimum required number of spaces by more than 10 percent.*

(...)

*H. For office, industrial, and public uses where there are more than 20 parking spaces for employees on the site, at least 10 percent of the required employee parking spaces shall be reserved for carpool use before 9:00 a.m. on weekdays. The spaces will be the closest to the building entrance, except for any disabled parking and those signed for exclusive customer use. The carpool/vanpool spaces shall be clearly marked "Reserved – Carpool/Vanpool Before 9:00 a.m."*

**Staff Finding 15:** The proposal does not exceed the minimum parking requirements and will not provide spaces signed for exclusive customer use. Required employee parking spaces (see Finding 14) equals 35. As the proposed new school is a public use, the applicant is required to provide four carpool spaces located closest to the building and signed appropriately. Please see Condition of Approval 5. Subject to the Conditions of Approval, these criteria are met.

(...)

*46.120 DRIVEWAYS REQUIRED ON SITE*

*Any school or other meeting place which is designed to accommodate more than 25 people at one time shall provide a 15-foot-wide driveway designed for continuous forward flow of passenger vehicles for the purpose of loading and unloading passengers. Depending on functional requirements, the width may be increased with Planning Director approval*

**Staff Finding 16:** The proposal provides a 24 foot driveway that provides continuous forward flow through the west parking area by way of the two accessways located on Oxford Street. The driveway has been designed for the purpose of loading/unloading of passengers as outlined in the applicant’s memo dated March 2, 2016 and found in Exhibit PC-5. The applicant also proposes a parent/student loading area along the Bittner Street frontage. These criteria are met.

**46.130 OFF-STREET LOADING SPACES**

*Buildings or structures to be built or substantially altered, which receive and distribute material or merchandise by truck, shall provide and maintain off-street loading and maneuvering space. The dimensional standard for loading spaces is a minimum of 14 feet wide by 20 feet long or proportionate to accommodate the size of delivery trucks that typically serve the proposed use as follows:*

Land Use	Gross Floor Area	
	At Which First Berth Is Required	At Which Second Berth Is Required
(...)		
<i>Institutional: Schools</i>	<i>10,000</i>	<i>100,000</i>
(...)		

**Staff Finding 17:** The applicant proposes a new school building with a gross floor area of 61,680 sq. ft., which requires one loading space. The applicant has proposed a 24 foot by 37 foot loading area on the west side of the building. This criterion is met.

(...)

**46.150 DESIGN AND STANDARDS**

*The following standards apply to the design and improvement of areas used for vehicle parking, storage, loading, and circulation:*

**A. Design Standards.**

1. *“One standard parking space” means a minimum for a parking stall of eight feet in width and 16 feet in length. These stalls shall be identified as “compact.” To accommodate larger cars, 50 percent of the required parking spaces shall have a minimum dimension of nine feet in width and 18 feet in length (nine feet by 18 feet). When multi-family parking stalls back onto a main driveway, the stalls shall be nine feet by 20 feet. Parking for development in water resource areas may have 100 percent compact spaces.*
2. *Disabled parking and maneuvering spaces shall be consistent with current federal dimensional standards and subsection B of this section and placed nearest to accessible building entryways and ramps.*

(...)

**Staff Finding 18: The applicant proposes 14 parking spaces of eight feet by 16 feet, 69 spaces of nine feet by 18 feet (78%), and five spaces that meet federal ADA standards and are located nearest to accessible building entryways and ramps. These criteria are met.**

4. *Service drives shall be designed and constructed to facilitate the flow of traffic, provide maximum safety of traffic access and egress, and maximum safety of pedestrians and vehicular traffic on the site.*
5. *Each parking and/or loading space shall have clear access, whereby the relocation of other vehicles to utilize the parking space is not required.*
6. *Except for single- and two-family residences, any area intended to be used to meet the off-street parking requirements as contained in this chapter shall have all parking spaces clearly marked using a permanent paint. All interior drives and access aisles shall be clearly marked and signed to show direction of flow and maintain vehicular and pedestrian safety. Permeable parking surface spaces may have an alternative delineation for parking spaces.*
7. *Except for residential parking, and parking for public parks and trailheads, at least 50 percent of all areas used for the parking and/or storage and/or maneuvering of any vehicle, boat and/or trailer shall be improved with asphalt or concrete surfaces according to the same standards required for the construction and acceptance of City streets. The remainder of the areas used for parking may use a permeable paving surface designed to reduce surface runoff. Parking for public parks or trailheads may use a permeable paving surface designed to reduce surface runoff for all parking areas. Where a parking lot contains both paved and unpaved areas, the paved areas shall be located closest to the use which they serve.*

**Staff Finding 19: The applicant proposal has designed the service drive and loading area to minimize vehicular interaction with pedestrians, bicyclists, and other vehicles, thus maximizing safety. All parking and loading spaces are designed with clear access and no relocation of other vehicles would be required. All parking, loading, and driveway surfaces will be paved and appropriately marked as required. These criteria are met.**

(...)

9. *Access drives from the street to off-street parking or loading areas shall be designed and constructed to facilitate the flow of traffic and provide maximum safety for pedestrian and vehicular traffic on the site. The number of access drives shall be limited to the minimum that will allow the property to accommodate and service the anticipated traffic. Access drives shall be clearly and permanently marked and defined through use of rails, fences, walls, or other barriers or markers on frontage not occupied by service drives.*
10. *Access drives shall have a minimum vision clearance as provided in Chapter [42](#) CDC, Clear Vision Areas.*
11. *Parking spaces along the boundaries of a parking lot or adjacent to interior landscaped areas or sidewalks shall be provided with a wheel stop at least four inches high located two feet back from the front of the parking stall. Such parking spaces may be provided without wheel stops if the sidewalks or landscaped areas adjacent the parking stalls are two feet wider than the minimum width.*

**Staff Finding 20:** The applicant proposes three access drives that meet City Engineer requirements, as well as Tualatin Valley Fire & Rescue standards for access. The access drives are designed and will be clearly defined to provide maximum safety for pedestrians, bicyclists, and vehicular traffic as outlined in the DKS Memorandum dated November 23, 2015. All access drives meet clear vision area requirements (see Finding 8). Wheel stops will be provided for all parking spaces as shown in Plan Sheet LU2.02. These criteria are met.

12. *Off-street parking and loading areas shall be drained in accordance with plans and specifications approved by the City Engineer. Storm drainage at commercial sites may also have to be collected to treat oils and other residue.*

**Staff Finding 21:** The applicant identifies all stormwater from off-street parking and loading areas to be collected and conveyed to the treatment and detention pond located on the south end of the subject property (Plan Sheet LU1.05). The applicant designed the stormwater system in consultation and with the approval of the City Engineer. This criterion is met.

13. *Artificial lighting on all off-street parking facilities shall be designed to deflect all light downward away from surrounding residences and so as not to create a hazard to the public use of any road or street.*

**Staff Finding 22:** The applicant has proposed an illumination plan (Plan Sheet LU4.01) that provides on-site lighting for off-street parking areas that is deflected downward away from surrounding residences and public rights-of-way. This criterion is met.

14. *Directional arrows and traffic control devices which are placed on parking lots shall be identified.*

(...)

16. *Visitor or guest parking must be identified by painted "GUEST" or "VISITOR."*

17. *The parking area shall have less than a five percent grade. No drainage across adjacent sidewalks or walkways is allowed.*

**Staff Finding 23:** The applicant proposes directional arrows and traffic control devices per DKS Memorandum dated November 23, 2015. No visitor or guest parking spaces are proposed. The grade of the west parking lot is 2.7 percent and the grade of the south parking lot is 4.6 percent. The applicant design proposes parking area stormwater collection through a stormwater planter on the far west parking area and eight catch basins located of throughout the remainder of the parking areas. The design does not propose drainage across adjacent sidewalks or walkways. These criteria are met.

18. *Commercial, office, industrial, and public parking lots may not occupy more than 50 percent of the main lot frontage of a development site. The remaining frontage shall comprise buildings or landscaping. If over 50 percent of the lineal frontage comprises parking lot, the landscape strip between the right-of-way and parking lot shall be increased to 15 feet wide and*

*shall include terrain variations (e.g., one-foot-high berm) plus landscaping. The defensible space of the parking lot should not be compromised.*

**Staff Finding 24:** The subject property has 829.2 lineal feet of frontage along the rights-of-way. The applicant is proposing 380 lineal feet of parking lot to occupy the lot frontage, which equates to 45.8 percent. Therefore, no increased landscape strips or berms are required. This criterion is met.

*19. Areas of the parking lot improved with asphalt or concrete surfaces shall be designed into areas of 12 or less spaces through the use of defined landscaped area. Groups of 12 or less spaces are defined as:*

- a. Twelve spaces in a row, provided there are no abutting parking spaces, as in the case when the spaces are abutting the perimeter of the lot; or*
- b. Twelve spaces in a group with six spaces abutting together; or*
- c. Two groups of 12 spaces abutting each other, but separated by a 15-foot-wide landscape area including a six-foot-wide walkway.*

*(...)*

**Staff Finding 25:** The applicant proposal provides two paved parking areas. The east parking area and most of the west parking area meets these criteria, however the configuration of the 14 compact spaces in the west parking area only provides a nine foot landscape buffer with no walkway. The applicant will redistribute the parking spaces to meet the groups of 12 criteria while still providing 88 parking spaces. Subject to Condition of Approval 6, these criteria are met.

*20. Pedestrian walkways shall be provided in parking areas having 20 or more spaces. Walkways or sidewalks shall be constructed between major buildings/activity areas...Walkways shall be constructed using a material that visually contrasts with the parking lot and driveway surface. Walkways shall be further identifiable to pedestrians and motorists by grade separation, walls, curbs, surface texture, and/or landscaping. Walkways shall be six feet wide. The arrangement and layout of the paths shall depend on functional requirements.*

**Staff Finding 26:** The applicant proposes new sidewalks along the entire frontage of the subject property (Plan Sheet LU1.00). The proposal also includes internal pedestrian walkways to facilitate the movement of people from their vehicles and activity areas to the building entryways. The internal walkways will be six feet wide, have pavement markings and surface texture, or be accommodated above a curb. This criterion is met.

*21. The parking and circulation patterns are easily comprehended and defined. The patterns shall be clear to minimize traffic hazards and congestion and to facilitate emergency vehicles.*

*22. The parking spaces shall be close to the related use.*

*23. Permeable parking spaces shall be designed and built to City standards.*



**Staff Finding 27:** The proposal has been designed for ease of use and the safety of pedestrians, bicyclists, vehicular traffic, and emergency vehicles. No permeable parking spaces are proposed. The proposed parking spaces have been located to make the most efficient use of the site and some spaces exceed the distance standards. The applicant has requested a variance to accommodate the design not meeting the parking space distance requirements. Please refer to Staff Findings 128 to 134. These criteria are met.

*B. Accessible parking standards for persons with disabilities. If any parking is provided for the public or visitors, or both, the needs of the people with disabilities shall be based upon the following standards or current applicable federal standards, whichever are more stringent:*

1. *Minimum number of accessible parking space requirements (see following table):*

<i>MINIMUM REQUIRED NUMBER OF TOTAL PARKING SPACES</i>	<i>TOTAL NUMBER OF ACCESSIBLE SPACES</i>	<i>NUMBER OF VAN-ACCESSIBLE SPACES REQUIRED, OF TOTAL</i>	<i>SPACES SIGNED "WHEELCHAIR USE ONLY"</i>
<i>(...)</i>			
76 – 100	4	1	–
<i>(...)</i>			

**Staff Finding 28:** The proposal is required to provide a minimum of 97 parking spaces, which then requires four accessible spaces. The four spaces shall include one van-accessible space. The applicant has proposed four accessible spaces and one van-accessible space (Plan Sheet LU1.02). These criteria are met.

2. *Location of parking spaces. Parking spaces for the individual with a disability that serve a particular building shall be located on the shortest possible accessible circulation route to an accessible entrance to a building. In separate parking structures or lots that do not serve a particular building, parking spaces for the persons with disabilities shall be located on the shortest possible circulation route to an accessible pedestrian entrance of the parking facility.*

3. *Accessible parking space and aisle shall meet ADA vertical and horizontal slope standards.*

4. *Where any differences exist between this section and current federal standards, those standards shall prevail over this code section.*

5. *One in every eight accessible spaces, but not less than one, shall be served by an access aisle 96 inches wide.*

6. *Van-accessible parking spaces shall have an additional sign marked "Van Accessible" mounted below the accessible parking sign. A van-accessible parking space reserved for wheelchair users shall have a sign that includes the words "Wheelchair Use Only." Van-accessible parking shall have an adjacent eight-foot-wide aisle. All other accessible stalls shall*

have a six-foot-wide aisle. Two vehicles may share the same aisle if it is between them. The vertical clearance of the van space shall be 96 inches

**Staff Finding 29:** The applicant proposal has located the accessible parking spots nearest the building entryway. All accessible spaces meet ADA standards (Plan Sheet LU1.02) . One accessible space has a 96 inch access aisle that will be signed “Van Accessible” and “Wheelchair Use Only”. The remaining four accessible spaces have six-foot-wide access aisles. These criteria are met.

(...)

D. *Bicycle facilities and parking.*

1. *Provisions shall be made for pedestrian and bicycle ways if such facilities are shown on an adopted plan.*
2. *Bicycle parking facilities shall either be lockable enclosures in which the bicycle is stored, or secure stationary racks which accommodate bicyclist’s locks securing the frame and both wheels. The bicycle parking shall be no more than 50 feet from the entrance to the building, well-lit, observable, and properly signed.*

**Staff Finding 30:** The applicant proposes to improve the two existing pedestrian pathways that connect the subject property to Oregon City Loop and Oregon City Blvd. Both pathways are included in the 2013 West Linn Trails Plan. No bicycle routes are within or adjacent to the subject property. The applicant proposes to provide 40 secure stationary racks that are well-lit, observable, and properly signed. The applicant proposes 20 of the spaces to be within 50 feet of the entrance and is requesting a variance to locate the remaining 20 covered spaces 130 feet from the entrance. Please refer to Staff Findings 128 to 134. Subject to approval of the variance, these criteria are met.

3. *Bicycle parking must be provided in the following amounts:*

<i>LAND USE CATEGORY</i>	<i>MINIMUM REQUIRED BICYCLE PARKING SPACES</i>	<i>MINIMUM COVERED AMOUNT</i>
(...)		
<i>Schools – Elementary</i>	<i>2 spaces per classroom</i>	<i>50%</i>
(...)		

**Staff Finding 31:** The proposed new school building will include 18 classrooms, thus requiring 36 bicycle parking spaces. The applicant proposes 20 uncovered and 20 covered spaces. This criterion is met.

(...)

F. (See Figures 1 and 2 below.) Minimum Standards for Parking Lot Layout

ANGLE OF PARKING	DIRECTION OF PARKING	AISLE WIDTH		DIMENSION 'A'		DIMENSION 'B'	
		STALL WIDTH		STALL WIDTH		STALL WIDTH	
		9.0'	8.0'	9.0'	8.0'	9.0'	8.0'
(...)							
90°	DRIVE-IN	23.0'	23.0'	18.0'	16.0'	9.0'	8.0'
(...)							

**Staff Finding 32:** The proposal is for all parking spaces to be at a 90 degree angle, which requires a drive aisle width of 23 feet regardless of whether the space is standard or compact. The applicant proposes 24 foot drive aisles for all parking spaces. This criterion is met.

**VII. CHAPTER 48, ACCESS, EGRESS AND CIRCULATION**

48.025 ACCESS CONTROL

B. Access Control Standards

1. Traffic impact analysis requirements. The City or other agency with access jurisdiction may require a traffic study prepared by a qualified professional to determine access, circulation and other transportation requirements. (See also CDC [55.125](#), Traffic Impact Analysis.)

**Staff Finding 33:** Neither the City nor ODOT requires a traffic impact analysis (TIA) for the applicant’s proposal. Please refer to Staff Finding 105. This criterion is met.

2. The City or other agency with access permit jurisdiction may require the closing or consolidation of existing curb cuts or other vehicle access points, recording of reciprocal access easements (i.e., for shared driveways), development of a frontage street, installation of traffic control devices, and/or other mitigation as a condition of granting an access permit, to ensure the safe and efficient operation of the street and highway system. Access to and from off-street parking areas shall not permit backing onto a public street.

**Staff Finding 34:** The applicant has collaborated with the City Engineer to design access to the subject property that enhances safety and convenience for all travel modes. The design has no parking areas that back onto a public street. This criterion is met.

3. *Access options. When vehicle access is required for development (i.e., for off-street parking, delivery, service, drive-through facilities, etc.), access shall be provided by one of the following methods (planned access shall be consistent with adopted public works standards and TSP). These methods are “options” to the developer/subdivider.*

a) *Option 1. Access is from an existing or proposed alley or mid-block lane. If a property has access to an alley or lane, direct access to a public street is not permitted.*

b) *Option 2. Access is from a private street or driveway connected to an adjoining property that has direct access to a public street (i.e., “shared driveway”). A public access easement covering the driveway shall be recorded in this case to assure access to the closest public street for all users of the private street/drive.*

c) *Option 3. Access is from a public street adjacent to the development lot or parcel. If practicable, the owner/developer may be required to close or consolidate an existing access point as a condition of approving a new access. Street accesses shall comply with the access spacing standards in subsection (B) (6) of this section.*

**Staff Finding 35: The applicant proposes three access points to subject property via Option 3. The applicant has collaborated with the City Engineer to design the access to enhance safety and convenience for all travel modes. These criteria are met.**

4. *Subdivisions fronting onto an arterial street.*

(...)

5. *Double-frontage lots.*

(...)

**Staff Finding 36: The applicant is not proposing a subdivision. The subject property is not a double-frontage lot nor is it located on an arterial. These criteria do not apply.**

6. *Access spacing.*

a. *The access spacing standards found in Chapter 8 of the adopted Transportation System Plan (TSP) shall be applicable to all newly established public street intersections and non-traversable medians.*

b. *Private drives and other access ways are subject to the requirements of CDC [48.060](#).*

**Staff Finding 37: The proposal does not create any new intersections or non-traversable medians. CDC 48.060 is addressed in Staff Findings 43 to 46. These criteria are met.**

(...)

C. *Street connectivity and formation of blocks required.*

*In order to promote efficient vehicular and pedestrian circulation throughout the City, land divisions and large site developments shall produce complete blocks bounded by a connecting network of public and/or private streets, in accordance with the following standards:*

(...)

**Staff Finding 38: The applicant's proposal does not create any new blocks. This criterion is met.**

*2. Street standards. Public and private streets shall also conform to Chapter 92 CDC, Required Improvements, and to any other applicable sections of the West Linn Community Development Code and approved TSP.*

**Staff Finding 39: Proposed street designs and improvements are consistent with the provisions of the West Linn Community Development Code and the West Linn Transportation System Plan. The applicant collaborated with the City Engineer to design accessways and street cross-sections to enhance safety and convenience for all travel modes. This criterion is met.**

(...)

*48.030 MINIMUM VEHICULAR REQUIREMENTS FOR RESIDENTIAL USES*

(...)

*E. Access and/or service drives for multi-family dwellings shall be fully improved with hard surface pavement:*

(...)

*3. Minimum vertical clearance of 13 feet, six inches.*

*4. Appropriate turnaround facilities per Fire Chief's standards for emergency vehicles when the drive is over 150 feet long. Fire Department turnaround areas shall not exceed seven percent grade unless waived by the Fire Chief.*

*5. The grade shall not exceed 10 percent on average, with a maximum of 15 percent.*

*6. A minimum centerline turning radius of 45 feet for the curve.*

**Staff Finding 40: The applicant proposal has no vertical clearance obstructions. Both fire access drives exceed 150 feet and both have turnaround facilities that meet Fire Chief Standards, including a minimum 45 foot turning radius for the curve. The north access turnaround has a maximum grade of 2.9 percent, while the south access turnaround has a maximum grade of 4.6 percent. The average grade of the north access drive is 0.9 percent and the south access drive is 0.4 percent. The 24 foot fire access drives do not provide enough space to allow parking and still meet the Fire Chief's 20 foot horizontal space requirement. The applicant shall prohibit parking on the fire access drives per Condition of Approval 8. Subject to the Condition of Approval, these criteria are met.**

*48.040 MINIMUM VEHICLE REQUIREMENTS FOR NON-RESIDENTIAL USES*

*Access, egress, and circulation system for all non-residential uses shall not be less than the following:*

*A. Service drives for non-residential uses shall be fully improved with hard surface pavement:*

*1. With a minimum of 24-foot width when accommodating two-way traffic; or*

*2. With a minimum of 15-foot width when accommodating one-way traffic. Horizontal clearance shall be two and one-half feet wide on either side of the driveway.*

3. Meet the requirements of CDC 48.030(E)(3) through (6).
4. Pickup window driveways may be 12 feet wide unless the Fire Chief determines additional width is required.

**Staff Finding 41: The applicant proposes all accessways and service drives to be hard surface pavement with a width of 24 feet. Please refer to Staff Finding 40. These criteria are met.**

- B. All non-residential uses shall be served by one or more service drives as determined necessary to provide convenient and safe access to the property and designed according to CDC 48.030(A). In no case shall the design of the service drive or drives require or facilitate the backward movement or other maneuvering of a vehicle within a street, other than an alley.
- C. All on-site maneuvering and/or access drives shall be maintained pursuant to CDC 46.130.
- D. Gated accessways to non-residential uses are prohibited unless required for public safety or security.

**Staff Finding 42: The subject property does not take access from an arterial street, thus 48.030(A) does not apply. The proposed design does not require or facilitate any backward movement or maneuvering within the street. All access drives and parking lot maneuvering aisles will be maintained pursuant to 46.130 as shown in Staff Findings 17 to 32. The applicant proposes a vehicle gate on the north fire access lane. The gate is located 20 feet north of the refuse/recycling/loading area and acts as public safety mechanism to prohibit vehicular access to the playground area located on the north side of the new school building. These criteria are met.**

(...)

**48.060 WIDTH AND LOCATION OF CURB CUTS AND ACCESS SEPARATION REQUIREMENTS**

- A. Minimum curb cut width shall be 16 feet.
- B. Maximum curb cut width shall be 36 feet, except along Highway 43 in which case the maximum curb cut shall be 40 feet. For emergency service providers, including fire stations, the maximum shall be 50 feet.

**Staff Finding 43: The applicant proposes three accessways requiring a curb cut. Two of the curb cuts are proposed at 50 feet and the third at 60 feet. The applicant shall redesign the accessways to meet the maximum curb cut width of 36 feet. Subject to Condition of Approval 7, these criteria are met.**

C. No curb cuts shall be allowed any closer to an intersecting street right-of-way line than the following:

1. On an arterial when intersected by another arterial, 150 feet.

(...)

6. On a local street when intersecting any other street, 35 feet.

**Staff Finding 44: The applicant proposes two curb cuts on Oxford Street to provide access to the west parking lot and service drive/fire access lane. The curb cuts are aligned to create 4-**

way intersections with Exeter and Sussex Streets. The curb cuts are a distance of 140 feet from one another and the curb cut aligned with Exeter Street is 220 feet from the intersection with Bittner Street. The third curb cut provides parking lot and fire access from Bittner Street to the south side of the proposed new school building. The curb cut is located 130 feet from the intersection with Oxford Street. These criteria are met.

*D. There shall be a minimum distance between any two adjacent curb cuts on the same side of a public street, except for one-way entrances and exits, as follows:*

- 1. On an arterial street, 150 feet.*
- 2. On a collector street, 75 feet.*
- 3. Between any two curb cuts on the same lot or parcel on a local street, 30 feet.*

**Staff Finding 45: The subject property is adjacent to a neighborhood route and a local street. These criteria do not apply. The distance between curb cuts are 140 feet and 350 feet. These criteria are met.**

*E. A rolled curb may be installed in lieu of curb cuts and access separation requirements.*

*F. Curb cuts shall be kept to the minimum, particularly on Highway 43. Consolidation of driveways is preferred. The standard on Highway 43 is one curb cut per business if consolidation of driveways is not possible.*

*G. Adequate line of sight pursuant to engineering standards should be afforded at each driveway or accessway.*

**Staff Finding 46: The applicant has collaborated with the City Engineer to design the placement of curb cuts. All accessways meet clear vision area requirements (refer to Staff Findings 7-8) and will adhere to engineering standards per Condition of Approval 2. These criteria are met.**

(...)

#### 48.080 BICYCLE AND PEDESTRIAN CIRCULATION

(...)

*c. Bicycle and pedestrian ways at commercial or industrial sites shall be provided according to the provisions of Chapter 55 CDC, Design Review.*

**Staff Finding 47: The proposal is not for a commercial or industrial site, but the applicant has collaborated with the City Engineer to design access and circulation to and through the subject property to enhance safety and convenience for all travel modes. These criteria are met.**

### **VIII. CHAPTER 52, SIGNS**

#### 52.110 VARIANCES

*A. Sign height and sign area variances shall be a Class II variance, and shall be reviewed pursuant to the provisions of subsection C of this section and Chapter 75 CDC.*

(...)

C. *The granting authority may grant a variance from the requirements of this chapter if it is established that:*

1. *The architectural design of a building, the location of a building site or location of building thereon, or some other circumstance relating to the sign proposal, is unusual or unique and that, because of this, a hardship will be created in that the applicant will be denied an opportunity to identify their business or location relatively equal to the opportunity accorded other members of the community not burdened with such unusual or unique architectural design, building site, or other circumstance;*
2. *The design is consistent with the request and will not be injurious to the neighborhood in which the property is located or to property established to be affected by the request; and*
3. *The request is the minimum variance necessary to provide reasonable signage for the property affected.*

**Staff Finding 48: The applicant has requested a Class II Variance to increase the maximum allowable area of an on-wall sign for a public use. The variance will create an opportunity for reasonable signage to identify the new Sunset Primary School and will not be injurious to the neighborhood as it will not be illuminated. Refer to Staff Findings 128 to 134. Subject to approval of the variance, these criteria are met.**

(...)

#### 52.210 APPROVAL STANDARDS

*All signs shall meet the following standards:*

- A. *The scale of the sign and its components shall be appropriate for its location and consistent with the applicable design standards.*
- B. *The size, location, or manner of illumination shall not create a traffic hazard and shall not hide from view any traffic or street sign or signal.*
- C. *The sign shall be located in compliance with Chapter [42](#) CDC, Clear Vision Area.*
- D. *Signs and sign structures located over vehicular driveways and pedestrian walkways shall allow at least 15 feet of clearance over driveways and eight feet of clearance over walkways.*
- E. *The light from any illuminated sign shall be shaded, fully shielded such that no light is emitted above the horizontal plane, and directed or reduced so that glare is minimized.*
- F. *Signs shall be located to preserve existing trees, topography and natural drainage, to the extent possible consistent with the installation of the sign.*

**Staff Finding 49: The applicant proposes one on-wall sign and one freestanding sign. The on-wall sign will not be illuminated and 12 feet above the pedestrian walkway. The free standing sign is not located in a clear vision area and will be illuminated by lights directed at the sign and a backlit reader board. These criteria are met.**

G. *All permanent signs shall be located within a landscaped area or installed on a wood, stone, or other base structure that meets the following standards:*



1. Signs shall be installed on a base with a maximum height of two feet, a minimum width at least one-half as wide as the sign face, and a depth equal to or greater than the depth of the sign.
2. In the event a sign is erected on a multiple-pole or piling structure, the base required by subsection (G)(1) of this section shall be apportioned among each of the upright members.
3. Any wood used in a base shall be treated against water damage and insect assault.

**Staff Finding 50: The applicant proposes the freestanding sign to be located within a landscape area, have a concrete base two feet in height that is the width of the sign and the same depth as the sign. These criteria are met.**

*H. Manual changeable copy signs shall be designed to minimize the opportunity for unauthorized personnel to change the sign copy.*

*I. Electronic changeable copy signs are permitted in business centers only, either as separate signs or as part of a larger sign. The approval authority may impose conditions of approval regarding the frequency of copy change, the hours of operation, and the methods by which the message is changed in order to assure compliance with the standards of this section and this chapter. Electronic changeable copy signs are subject to the following requirements:*

1. The sign face for the electronic changeable copy sign or portion of a sign may not exceed 24 square feet; provided, however, that electronic changeable copy signs with greater than 24 square feet may be approved through the conditional use process.
2. The design and placement of the sign shall not adversely affect vehicular and pedestrian safety.
3. The sign shall comply with all other requirements of this chapter.

*J. Where both sides of a sign may be viewed from a right-of-way, the signs shall be double-faced.*

**Staff Finding 51: The applicant proposes a free standing, manual changeable copy sign. The design will not allow unauthorized personnel to have access to change the sign copy. The free standing sign will parallel to the right-of-way and only visible from one side. These criteria are met.**

#### 52.300 PERMANENT SIGN DESIGN STANDARDS

*Public Uses – Requires City Approval and Allows Illumination*

*Freestanding Signs – Schools Allowed Two*

*Maximum Size – 24 sq. ft.*

*Maximum Height – 20 ft.*

*ROW Setback – 5 ft.*

*On-Wall Signs – No Number Limit for Schools*

*Maximum Size – 18 sq. ft. total for all signs*

*Maximum Height – 25 ft.*

**Staff Finding 52: The applicant proposes a free standing sign that has a copy area of 18 square feet, a maximum height of six feet, and a right-of-way setback of nine feet. The**

applicant proposes an on-wall sign of 42 square feet and is requesting a variance for the maximum size. Refer to Staff Findings 128 to 134. The proposed maximum height of the on-wall sign is 15 feet. Subject to approval of the variance, these criteria are met.

## **IX. CHAPTER 54, LANDSCAPING**

### **54.020 APPROVAL CRITERIA**

A. *Every development proposal requires inventorying existing site conditions which include trees and landscaping. In designing the new project, every reasonable attempt should be made to preserve and protect existing trees and to incorporate them into the new landscape plan. Similarly, significant landscaping (e.g., bushes, shrubs) should be integrated. The rationale is that saving a 30-foot-tall mature tree helps maintain the continuity of the site, they are qualitatively superior to two or three two-inch caliper street trees, they provide immediate micro-climate benefits (e.g., shade), they soften views of the street, and they can increase the attractiveness, marketability, and value of the development.*

B. *To encourage tree preservation, the parking requirement may be reduced by one space for every significant tree that is preserved in the parking lot area for a maximum reduction of 10 percent of the required parking. The City Parks Supervisor or Arborist shall determine the significance of the tree and/or landscaping to determine eligibility for these reductions.*

**Staff Finding 53: The applicant proposes the reasonable retention of 77 percent of significant tree canopy coverage on the subject property and is not seeking a parking reduction based on significant trees preserved in the parking lot area. These criteria are met.**

C. *Developers must also comply with the municipal code chapter on tree protection.*

D. *Heritage trees. Heritage trees are trees which, because of their age, type, notability, or historical association, are of special importance. Heritage trees are trees designated by the City Council following review of a nomination. A heritage tree may not be removed without a public hearing at least 30 days prior to the proposed date of removal. Development proposals involving land with heritage tree(s) shall be required to protect and save the tree(s). Further discussion of heritage trees is found in the municipal code.*

**Staff Finding 54: The subject property contains no heritage trees. The applicant will comply with municipal code tree protection requirements during and after site development. These criteria are met.**

E. *Landscaping – By type, location and amount.*

(...)

2. *Non-residential uses. A minimum of 20 percent of the gross site area shall be landscaped. Parking lot landscaping may be counted in the percentage.*

**Staff Finding 55: Total site area is 320,149 square feet. The applicant proposal provides 104,597 (33 percent) square feet of landscape area. These criteria are met.**

3. All uses (residential uses (non-single-family) and non-residential uses):

a. The landscaping shall be located in defined landscaped areas which are uniformly distributed throughout the parking or loading area. There shall be one shade tree planted for every eight parking spaces. These trees shall be evenly distributed throughout the parking lot to provide shade. Parking lots with over 20 spaces shall have a minimum 10 percent of the interior of the parking lot devoted to landscaping. Pedestrian walkways in the landscaped areas are not to be counted in the percentage. The perimeter landscaping, explained in subsection (E)(3)(d) of this section, shall not be included in the 10 percent figure. Parking lots with 10 to 20 spaces shall have a minimum five percent of the interior of the parking lot devoted to landscaping. The perimeter landscaping, as explained above, shall not be included in the five percent. Parking lots with fewer than 10 spaces shall have the standard perimeter landscaping and at least two shade trees. Non-residential parking areas paved with a permeable parking surface may reduce the required minimum interior landscaping by one-third for the area with the permeable parking surface only.

**Staff Finding 56: The applicant proposes 88 parking spaces, thus requiring 11 parking lot shade trees. The applicant proposal includes 22 parking lot shade trees that are evenly distributed. The west parking lot contains more than 20 spaces and provides 14 percent interior landscape area. The east parking lot contains 12 spaces and provides 11 percent interior landscape area. These criteria are met.**

b. The landscaped areas shall not have a width of less than five feet.

c. The soils, site, proposed soil amendments, and proposed irrigation system shall be appropriate for the healthy and long-term maintenance of the proposed plant species.

**Staff Finding 57: The proposal provides all landscape areas at a width of greater than or equal to five feet. The applicant will provide appropriate planting mediums and irrigation for the long-term health of the landscape areas. These criteria are met.**

d. A parking, loading, or service area which abuts a street shall be set back from the right-of-way line by perimeter landscaping in the form of a landscaped strip at least 10 feet in width. When a parking, loading, or service area or driveway is contiguous to an adjoining lot or parcel, there shall be an intervening five-foot-wide landscape strip. The landscaped area shall contain:

- 1) Street trees spaced as appropriate to the species, not to exceed 50 feet apart on the average;
- 2) Shrubs, not to reach a height greater than three feet, six inches, spaced no more than five feet apart on the average; or
- 3) Vegetative ground cover such as grass, wildflowers, or other landscape material to cover 100 percent of the exposed ground within two growing seasons. No bark mulch shall be allowed except under the canopy of low level shrubs.

**Staff Finding 58: The proposal provides 12, 14, and 18 foot grass or herbaceous groundcover landscape strips between the west parking area and the street right-of-way. The portion of the west parking area abutting the neighboring properties provides a 10 or 12 foot landscape**

strip that will contain shrubs not to reach a height greater than three feet six inches. The east parking area provides a 14 foot grass landscape strip between the parking pavement and street right-of-way. All landscape strips contain street trees that average 24 feet distance from one another and no distance between two trees exceeds 50 feet. These criteria are met.

*e. If over 50 percent of the lineal frontage of the main street or arterial adjacent to the development site comprises parking lot, the landscape strip between the right-of-way and parking lot shall be increased to 15 feet in width and shall include terrain variations (e.g., one-foot-high berm) plus landscaping. This extra requirement only applies to one street frontage.*

**Staff Finding 59:** The subject property has 829.2 lineal feet of frontage along the rights-of-way. The applicant is proposing 380 lineal feet of parking lot to occupy the lot frontage, which equates to 45.8 percent. Therefore, no increased landscape strips or berms are required. This criterion is met.

*f. A parking, loading, or service area which abuts a property line shall be separated from the property line by a landscaped area at least five feet in width and which shall act as a screen and noise buffer, and the adequacy of the screen and buffer shall be determined by the criteria set forth in CDC 55.100(C) and (D), except where shared parking is approved under CDC 46.050.*

**Staff Finding 60:** The portion of the west parking area abutting the neighboring properties provides a 10 or 12 foot landscape strip that will contain shrubs not to reach a height greater than three feet six inches. The landscape strips will contain trees. Please refer to Staff Findings 84 to 87. This criterion is met.

*g. All areas in a parking lot not used for parking, maneuvering, or circulation shall be landscaped.*

*h. The landscaping in parking areas shall not obstruct lines of sight for safe traffic operation.*

**Staff Finding 61:** Staff incorporates applicant findings. These criteria are met.

*i. Outdoor storage areas, service areas (loading docks, refuse deposits, and delivery areas), and above-ground utility facilities shall be buffered and screened to obscure their view from adjoining properties and to reduce noise levels to acceptable levels at the property line. The adequacy of the buffer and screening shall be determined by the criteria set forth in CDC 55.100(C)(1).*

**Staff Finding 62:** Please see Staff Finding 84. This criterion is met.

*j. Crime prevention shall be considered and plant materials shall not be located in a manner which prohibits surveillance of public and semi-public areas (shared or common areas).*

*k. Irrigation facilities shall be located so that landscaped areas can be properly maintained and so that the facilities do not interfere with vehicular or pedestrian circulation.*

**Staff Finding 63: Staff incorporates applicant findings. These criteria are met.**

*l. For commercial, office, multi-family, and other sites, the developer shall select trees that possess the following characteristics:*

- 1) Provide generous "spreading" canopy for shade.*
- 2) Roots do not break up adjacent paving.*
- 3) Tree canopy spread starts at least six feet up from grade in, or adjacent to, parking lots, roads, or sidewalks unless the tree is columnar in nature.*
- 4) No sticky leaves or sap-dripping trees (no honey-dew excretion).*
- 5) No seed pods or fruit-bearing trees (flowering trees are acceptable).*
- 6) Disease-resistant.*
- 7) Compatible with planter size.*
- 8) Drought-tolerant unless irrigation is provided.*
- 9) Attractive foliage or form all seasons.*

*m. Plant materials (shrubs, ground cover, etc.) shall be selected for their appropriateness to the site, drought tolerance, year-round greenery and coverage, staggered flowering periods, and avoidance of nuisance plants (Scotch broom, etc.).*

**Staff Finding 64: Staff incorporates applicant findings. These criteria are met.**

*(...)*

**54.030 PLANTING STRIPS FOR MODIFIED AND NEW STREETS**

*All proposed changes in width in a public street right-of-way or any proposed street improvement shall, where feasible, include allowances for planting strips. Plans and specifications for planting such areas shall be integrated into the general plan of street improvements. This chapter requires any multi-family, commercial, or public facility which causes change in public right-of-way or street improvement to comply with the street tree planting plan and standards.*

**Staff Finding 65: The applicant proposal will meet street standards per Conditions of Approval 2 and 3. These criteria are met.**

**54.040 INSTALLATION**

- A. All landscaping shall be installed according to accepted planting procedures.*
- B. The soil and plant materials shall be of good quality.*
- C. Landscaping shall be installed in accordance with the provisions of this code.*
- D. Certificates of occupancy shall not be issued unless the landscaping requirements have been met or other arrangements have been made and approved by the City such as the posting of a bond.*

**54.050 PROTECTION OF STREET TREES**

*Street trees may not be topped or trimmed unless approval is granted by the Parks Supervisor or, in emergency cases, when a tree imminently threatens power lines.*

54.060 MAINTENANCE

A. The owner, tenant and their agent, if any, shall be jointly and severally responsible for the maintenance of all landscaping which shall be maintained in good condition so as to present a healthy, neat, and orderly appearance and shall be kept free from refuse and debris.

B. All plant growth in interior landscaped areas shall be controlled by pruning, trimming, or otherwise so that:

1. It will not interfere with the maintenance or repair of any public utility;
2. It will not restrict pedestrian or vehicular access; and
3. It will not constitute a traffic hazard because of reduced visibility.

**Staff Finding 66: The applicant proposal will comply. These criteria are met.**

54.070 SPECIFICATION SUMMARY

<b>Area/Location</b>	<b>Landscaping Req'd.</b>
1. Between parking lot and R-O-W.	10 ft.
2. Between parking lot and other lot.	5 ft.
3. Between parking lot and R-O-W if parking lot comprises more than 50 percent of main R-O-W frontage.	15 ft.
4. Percentage of residential/multi-family site to be landscaped.	25%
5. Percentage of non-residential (commercial/industrial/office) site to be landscaped.	20%
6. Percentage of 10 – 25 car parking lot to be landscaped (excluding perimeter).	5%
7. Percentage of 1 – 9 car parking lot to be landscaped (excluding perimeter).	0%
8. Percentage of 26+ car parking lot to be landscaped (excluding perimeter).	10%

**Staff Finding 67: Please see Staff Findings 55 to 60. These criteria are met.**

**X. CHAPTER 55, DESIGN REVIEW**

55.100 APPROVAL STANDARDS – CLASS II DESIGN REVIEW

B. Relationship to the natural and physical environment.

1. The buildings and other site elements shall be designed and located so that all heritage trees, as defined in the municipal code, shall be saved. Diseased heritage trees, as determined by the City Arborist, may be removed at his/her direction.

**Staff Finding 68: The subject site contains no heritage trees. This criteria does not apply.**

*2. All heritage trees...all trees and clusters of trees ("cluster" is defined as three or more trees with overlapping driplines; however, native oaks need not have an overlapping dripline) that are considered significant by the City Arborist...shall be protected pursuant to the criteria of subsections (B)(2)(a) through (f) of this section...*

*a. Non-residential and residential projects on Type I and II lands shall protect all heritage trees and all significant trees and tree clusters by either the dedication of these areas or establishing tree conservation easements...*

**Staff Finding 69: The subject property is primarily Type IV lands (94%). Type I and II lands make up 1.25 percent of the entire site and no significant trees proposed to be removed from any of these areas. These criteria are met.**

*b. Non-residential and residential projects on non-Type I and II lands shall set aside up to 20 percent of the area to protect trees and tree clusters that are determined to be significant, plus any heritage trees...*

**Staff Finding 70: The subject property is 98.75 percent non-Type I or II lands with no heritage trees. The applicant has provided an Arborist Report and identified 62 significant trees, with 31,431 sq. ft. of canopy coverage (dripline plus 10 feet). The City Arborist visited the site on December 8, 2015 with applicant representatives and concurred with the significant tree inventory. The applicant has proposed a site design that avoided significant trees to the greatest possible extent. After careful site design considerations, the applicant proposes to remove 12 of the significant trees, with 7,129 sq. ft. of canopy coverage, due to site development activities. The remaining 50 significant trees are proposed to be retained and comprise 77 percent of the significant tree canopy coverage, well above the 20 percent standard. The Arborist Report identified 14 significant trees (eight located near the southeast corner of the proposed building and six near the stormwater facility) that are proposed to be retained that will need to be protected, monitored and possibly given therapy after site development. Even with the removal of these additional trees, the 20 percent standard will be met. In order to provide the 14 trees the best chance of survival, the applicant shall provide root zone protection per Condition of Approval 9. The applicant shall protect the retained significant trees, not already protected by required setbacks, through the recording of an easement as required in Condition of Approval 10. Subject to the Conditions of Approval, this criterion is met.**

*c. Where stubouts of streets occur on abutting properties, and the extension of those streets will mean the loss of significant trees, tree clusters, or heritage trees, it is understood that tree loss may be inevitable. In these cases, the objective shall be to minimize tree loss. These provisions shall also apply in those cases where access, per construction code standards, to a lot or parcel is blocked by a row or screen of significant trees or tree clusters.*

**Staff Finding 71: No street stubouts occur on abutting properties, nor do significant trees block access to the subject property. This criterion is met.**

*d. For both non-residential and residential development, the layout shall achieve at least 70 percent of maximum density for the developable net area. The developable net area excludes all Type I and II lands and up to 20 percent of the remainder of the site for the purpose of protection of stands or clusters of trees as defined in subsection (B)(2) of this section.*

*e. For arterial and collector street projects...*

*f. If the protection of significant tree(s) or tree clusters is to occur in an area of grading that is necessary for the development of street grades...compensate for the removal of the tree(s) on an "inch by inch" basis (e.g., a 48-inch Douglas fir could be replaced by 12 trees, each four-inch). The mix of tree sizes and types shall be approved by the City Arborist.*

**Staff Finding 72: The applicant proposal utilizes over 70 percent of the site for building footprint, parking areas, play fields and playgrounds, required landscape areas, fire access aisles, stormwater facilities, pedestrian and bicycle facilities, and the retention of significant trees. The subject property is not adjacent to arterial or collector streets. No significant trees will be removed for right-of-way improvements. These criteria are met.**

*3. The topography and natural drainage shall be preserved to the greatest degree possible.*

*4. The structures shall not be located in areas subject to slumping and sliding. The Comprehensive Plan Background Report's Hazard Map, or updated material as available and as deemed acceptable by the Planning Director, shall be the basis for preliminary determination.*

*5. There shall be adequate distance between on-site buildings and on-site and off-site buildings on adjoining properties to provide for adequate light and air circulation and for fire protection.*

**Staff Finding 73: Staff incorporates applicant findings. These criteria are met.**

*6. Architecture.*

*a. The proposed structure(s) scale shall be compatible with the existing structure(s) on site and on adjoining sites. Contextual design is required. Contextual design means respecting and incorporating prominent architectural styles, building lines, roof forms, rhythm of windows, building scale and massing of surrounding buildings in the proposed structure. The materials and colors shall be complementary to the surrounding buildings.*

**Staff Finding 74: Staff incorporates applicant findings. This criterion is met.**

*b. While there has been discussion in Chapter 24 CDC about transition, it is appropriate that new buildings should architecturally transition in terms of bulk and mass to work with, or fit, adjacent existing buildings. This transition can be accomplished by selecting designs that "step down" or "step up" from small to big structures and vice versa (see figure below). Transitions may also take the form of carrying building patterns and lines (e.g., parapets, windows, etc.) from the existing building to the new one.*



- c. *Contrasting architecture shall only be permitted when the design is manifestly superior to adjacent architecture in terms of creativity, design, and workmanship, and/or it is adequately separated from other buildings by distance, screening, grade variations, or is part of a development site that is large enough to set its own style of architecture.*
- d. *Human scale is a term that seeks to accommodate the users of the building and the notion that buildings should be designed around the human scale (i.e., their size and the average range of their perception). Human scale shall be accommodated in all designs by, for example, multi-light windows that are broken up into numerous panes, intimately scaled entryways, and visual breaks (exaggerated eaves, indentations, ledges, parapets, awnings, engaged columns, etc.) in the facades of buildings, both vertically and horizontally.*

**Staff Finding 75: Staff incorporates applicant findings. These criteria are met.**

- e. *The main front elevation of commercial and office buildings shall provide at least 60 percent windows or transparency at the pedestrian level to create more interesting streetscape and window shopping opportunities. One side elevation shall provide at least 30 percent transparency. Any additional side or rear elevation, which is visible from a collector road or greater classification, shall also have at least 30 percent transparency...*

**Staff Finding 76: Staff incorporates applicant findings. This criterion is met.**

- f. *Variations in depth and roof line are encouraged for all elevations. To vary the otherwise blank wall of most rear elevations, continuous flat elevations of over 100 feet in length should be avoided by indents or variations in the wall. The use of decorative brick, masonry, or stone insets and/or designs is encouraged. Another way to vary or soften this elevation is through terrain variations such as an undulating grass area with trees to provide vertical relief.*
- g. *Consideration of the micro-climate (e.g., sensitivity to wind, sun angles, shade, etc.) shall be made for building users, pedestrians, and transit users, including features like awnings.*
- h. *The vision statement identified a strong commitment to developing safe and attractive pedestrian environments with broad sidewalks, canopied with trees and awnings*
- i. *Sidewalk cafes, kiosks, vendors, and street furniture are encouraged. However, at least a four-foot-wide pedestrian accessway must be maintained per Chapter 53 CDC, Sidewalk Use.*

**Staff Finding 77: Staff incorporates applicant findings. These criteria are met.**

- 7. *Transportation Planning Rule (TPR) compliance. The automobile shall be shifted from a dominant role, relative to other modes of transportation, by the following means:*
  - a. *Commercial and office development shall be oriented to the street. At least one public entrance shall be located facing an arterial street; or....facing the local street with highest traffic levels...*

**Staff Finding 78: The applicant proposal is not a commercial or office development. The proposal is to construct a new school building, a public use, on the subject property. This**

criteria does not apply. However, the applicant proposal is consistent with the criteria as they have oriented the main public entrance to the intersection of Oxford and Bittner Streets and placed parking areas to the sides of the building. The site and building have been designed for ease of use and the safety of pedestrians, bicyclists, vehicular traffic, and emergency vehicles.

(...)

*c. Commercial, office, and multi-family projects shall be built as close to the adjacent main right-of-way as practical to facilitate safe pedestrian and transit access...*

**Staff Finding 79:** The applicant proposal is not a commercial, office, or multi-family development. The proposal is to construct a new school building, a public use, on the subject property. This criteria does not apply. However, the applicant proposal is consistent with the criteria as they have oriented the main public entrance to the intersection of Oxford and Bittner Streets and placed parking areas to the sides of the building. The site and building have been designed for ease of use and the safety of pedestrians, bicyclists, vehicular traffic, and emergency vehicles.

*d. Accessways, parking lots, and internal driveways shall accommodate pedestrian circulation and access by specially textured, colored, or clearly defined footpaths at least six feet wide. Paths shall be eight feet wide when abutting parking areas or travel lanes. Paths shall be separated from parking or travel lanes by either landscaping, planters, curbs, bollards, or raised surfaces...*

**Staff Finding 80:** The applicant design proposes clearly defined, six foot pedestrian facilities throughout both parking areas to facilitate safe circulation. They will be separated from parking or travel lanes. The proposal is for a new school and not a storefront. This criterion is met.

*e. Paths shall provide direct routes that pedestrians will use between buildings, adjacent rights-of-way, and adjacent commercial developments. They shall be clearly identified. They shall be laid out to attract use and to discourage people from cutting through parking lots and impacting environmentally sensitive areas.*

**Staff Finding 81:** Staff incorporates applicant findings. This criterion is met.

*f. At least one entrance to the building shall be on the main street, or as close as possible to the main street. The entrance shall be designed to identify itself as a main point of ingress/egress.*

*g. Where transit service exists, or is expected to exist, there shall be a main entrance within a safe and reasonable distance of the transit stop. A pathway shall be provided to facilitate a direct connection.*

*h. Projects shall bring at least part of the project adjacent to or near the main street right-of-way in order to enhance the height-to-width ratio along that particular street. (The "height-to-width ratio" is an architectural term that emphasizes height or vertical dimension of buildings*

adjacent to streets. The higher and closer the building is, and the narrower the width of the street, the more attractive and intimate the streetscape becomes.) For every one foot in street width, the adjacent building ideally should be one to two feet higher. This ratio is considered ideal in framing and defining the streetscape.

**Staff Finding 82: Staff incorporates applicant findings. These criteria are met.**

- i. These architectural standards shall apply to public facilities such as reservoirs, water towers, treatment plants, fire stations, pump stations, power transmission facilities, etc. It is recognized that many of these facilities, due to their functional requirements, cannot readily be configured to meet these architectural standards. However, attempts shall be made to make the design sympathetic to surrounding properties by landscaping, setbacks, buffers, and all reasonable architectural means.*
- j. Parking spaces at trailheads shall be located so as to preserve the view of, and access to, the trailhead entrance from the roadway. The entrance apron to the trailhead shall be marked: "No Parking," and include design features to foster trail recognition.*

**Staff Finding 83: Staff incorporates applicant findings. These criteria are met.**

- C. Compatibility between adjoining uses, buffering, and screening.*
  - 1. In addition to the compatibility requirements contained in Chapter 24 CDC, buffering shall be provided between different types of land uses; for example, buffering between single-family homes and apartment blocks. However, no buffering is required between single-family homes and duplexes or single-family attached units. The following factors shall be considered in determining the adequacy of the type and extent of the buffer:*
    - a. The purpose of the buffer, for example to decrease noise levels, absorb air pollution, filter dust, or to provide a visual barrier.*
    - b. The size of the buffer required to achieve the purpose in terms of width and height.*
    - c. The direction(s) from which buffering is needed.*
    - d. The required density of the buffering.*
    - e. Whether the viewer is stationary or mobile.*

**Staff Finding 84: Staff incorporates applicant findings. These criteria are met.**

- 2. On-site screening from view from adjoining properties of such things as service areas, storage areas, and parking lots shall be provided and the following factors will be considered in determining the adequacy of the type and extent of the screening:*
  - a. What needs to be screened?*
  - b. The direction from which it is needed.*
  - c. How dense the screen needs to be.*
  - d. Whether the viewer is stationary or mobile.*
  - e. Whether the screening needs to be year-round.*

**Staff Finding 85: Staff incorporates applicant findings. These criteria are met.**

3. Rooftop air cooling and heating systems and other mechanical equipment shall be screened from view from adjoining properties.

**Staff Finding 86: Staff incorporates applicant findings. These criteria are met.**

D. Privacy and noise.

1. Structures which include residential dwelling units shall provide private outdoor areas for each ground floor unit which is screened from view from adjoining units.
2. Residential dwelling units shall be placed on the site in areas having minimal noise exposure to the extent possible. Natural-appearing sound barriers shall be used to lessen noise impacts where noise levels exceed the noise standards contained in West Linn Municipal Code Section 5.487.
3. Structures or on-site activity areas which generate noise, lights, or glare shall be buffered from adjoining residential uses in accordance with the standards in subsection C of this section where applicable.
4. Businesses or activities that can reasonably be expected to generate noise in excess of the noise standards contained in West Linn Municipal Code Section 5.487 shall undertake and submit appropriate noise studies and mitigate as necessary to comply with the code. (See CDC [55.110\(B\)\(11\)](#) and [55.120\(M\)](#).)

*If the decision-making authority reasonably believes a proposed use may generate noise exceeding the standards specified in the municipal code, then the authority may require the applicant to supply professional noise studies from time to time during the user's first year of operation to monitor compliance with City standards and permit requirements.*

**Staff Finding 87: The proposal does not include residential dwelling units and complies with subsection C (see Staff Findings 84-86). The applicant submitted a noise study from BRC Acoustics & Audiovisual Design dated November 13, 2015 (Exhibit E of Applicant Submittal). The study concluded the proposal will comply with the West Linn noise regulations. These criteria are met.**

(...)

G. Demarcation of public, semi-public, and private spaces. The structures and site improvements shall be designed so that public areas such as streets or public gathering places, semi-public areas, and private outdoor areas are clearly defined in order to establish persons having a right to be in the space, to provide for crime prevention, and to establish maintenance responsibility. These areas may be defined by:

1. A deck, patio, fence, low wall, hedge, or draping vine;
2. A trellis or arbor;
3. A change in level;
4. A change in the texture of the path material;
5. Sign; or
6. Landscaping.

**Staff Finding 88: Staff incorporates applicant findings. These criteria are met.**

*H. Public transit.*

- 1. Provisions for public transit may be required where the site abuts an existing or planned public transit route. The required facilities shall be based on the following:
  - a. The location of other transit facilities in the area.*
  - b. The size and type of the proposed development.*
  - c. The rough proportionality between the impacts from the development and the required facility.**
- 2. The required facilities shall be limited to such facilities as the following:
  - a. A waiting shelter with a bench surrounded by a three-sided covered structure, with transparency to allow easy surveillance of approaching buses.*
  - b. A turnout area for loading and unloading designed per regional transit agency standards.*
  - c. Hard-surface paths connecting the development to the waiting and boarding areas.*
  - d. Regional transit agency standards shall, however, prevail if they supersede these standards.**
- 3. The transit stop shall be located as close as possible to the main entrance to the shopping center, public or office building, or multi-family project. The entrance shall not be more than 200 feet from the transit stop with a clearly identified pedestrian link.*
- 4. All commercial business centers (over three acres) and multi-family projects (over 40 units) may be required to provide for the relocation of transit stops to the front of the site if the existing stop is within 200 to 400 yards of the site and the exaction is roughly proportional to the impact of the development. The commercial or multi-family project may be required to provide new facilities in those cases where the nearest stop is over 400 yards away. The transit stop shall be built per subsection (H)(2) of this section.*
- 5. If a commercial business center or multi-family project is adjacent to an existing or planned public transit stop, the parking requirement may be reduced by the multiplier of 0.9, or 10 percent. If a commercial center is within 200 feet of a multi-family project, with over 80 units and pedestrian access, the parking requirement may be reduced by 10 percent or by a 0.90 multiplier.*
- 6. Standards of CDC 85.200(D), Transit Facilities, shall also apply.*

**Staff Finding 89: Staff incorporates applicant findings. These criteria are met.**

*I. Public facilities. An application may only be approved if adequate public facilities will be available to provide service to the property prior to occupancy.*

- 1. Streets. Sufficient right-of-way and slope easement shall be dedicated to accommodate all abutting streets to be improved to the City's Improvement Standards and Specifications. The City Engineer shall determine the appropriate level of street and traffic control improvements to be required, including any off-site street and traffic control improvements, based upon the transportation analysis submitted. The City Engineer's determination of developer obligation, the extent of road improvement and City's share, if any, of improvements and the timing of improvements shall be made based upon the City's systems development charge ordinance and capital improvement program, and the rough proportionality between the impact of the development and the street improvements...*

**Staff Finding 90: The applicant shall comply with the requirements and install improvements to meet the West Linn Public Works Standards. These criteria are met.**

(...)

3. *Municipal water. A registered civil engineer shall prepare a plan for the provision of water which demonstrates to the City Engineer's satisfaction the availability of sufficient volume, capacity, and pressure to serve the proposed development's domestic, commercial, and industrial fire flows. All plans will then be reviewed by the City Engineer.*

**Staff Finding 91: Water is available in Oxford Street to serve the new school building. The applicant was provided water modeling by the City Engineer and will extend an eight inch iron ductile water line down Oxford and Bittner Streets to replace the existing six inch cast iron water line. The replacement line will provide a loop and improve service in the general area, as well as provide adequate pressure to meet fire flow requirements and help eliminate the need for future replacement of the cast iron line after full street improvements have been made. The City Engineer has confirmed the water system has sufficient water volume and pressure to serve the new school building. The applicant shall complete and submit a fire flow test from a hydrant within 400 feet of the proposed building per Condition of Approval 11. Subject to the Conditions of Approval, these criteria are met.**

4. *Sanitary sewers. A registered civil engineer shall prepare a sewerage collection system plan which demonstrates sufficient on-site capacity to serve the proposed development. The City Engineer shall determine whether the existing City system has sufficient capacity to serve the development.*

**Staff Finding 92: The applicant has submitted a plan prepared by a registered civil engineer that will gravity flow to the existing sanitary sewer line in Bittner Street. The system will be built to appropriate standards. The City Engineer has confirmed the existing sanitary sewer line is in poor condition and not located within an established easement; therefore additional service connections and flow to this sanitary sewer line are prohibited. The City Engineer requires replacement of the line and the applicant has volunteered to install the line as part of Bittner Street construction activities. The City Engineer and applicant have agreed to coordinate and share the cost of installing the new sanitary sewer line in Bittner Street. Exhibit PC-6 outlines the proportional cost sharing the applicant and City have agreed upon and once constructed, the sanitary sewer line and system will have sufficient capacity to service the proposal. Subject to Condition of Approval 12, these criteria are met.**

5. *Solid waste and recycling storage areas. Appropriately sized and located solid waste and recycling storage areas shall be provided. Metro standards shall be used.*

**Staff Finding 93: The applicant proposal provides a screened solid waste and recycling area that meets Metro standards. These criteria are met.**

J. *Crime prevention and safety/defensible space.*

1. *Windows shall be located so that areas vulnerable to crime can be surveyed by the occupants.*
2. *Interior laundry and service areas shall be located in a way that they can be observed by others.*
3. *Mailboxes, recycling, and solid waste facilities shall be located in lighted areas having vehicular or pedestrian traffic.*

**Staff Finding 94: Staff incorporates applicant findings. These criteria are met.**

4. *The exterior lighting levels shall be selected and the angles shall be oriented towards areas vulnerable to crime.*
5. *Light fixtures shall be provided in areas having heavy pedestrian or vehicular traffic and in potentially dangerous areas such as parking lots, stairs, ramps, and abrupt grade changes.*
6. *Fixtures shall be placed at a height so that light patterns overlap at a height of seven feet which is sufficient to illuminate a person. All commercial, industrial, residential, and public facility projects undergoing design review shall use low or high pressure sodium bulbs and be able to demonstrate effective shielding so that the light is directed downwards rather than omni-directional. Omni-directional lights of an ornamental nature may be used in general commercial districts only.*

**Staff Finding 95: The applicant has provided a proposed lighting plan that illuminates all areas vulnerable to crime. The parking areas and primary pedestrian walkways are fully lighted and meet the seven foot overlap provision. The light fixtures will comply with bulb standards and be directed downward. These criteria are met.**

7. *Lines of sight shall be reasonably established so that the development site is visible to police and residents.*
8. *Security fences for utilities (e.g., power transformers, pump stations, pipeline control equipment, etc.) or wireless communication facilities may be up to eight feet tall in order to protect public safety. No variances are required regardless of location.*

**Staff Finding 96: Staff incorporates applicant findings. These criteria are met.**

- K. Provisions for persons with disabilities.*
1. *The needs of a person with a disability shall be provided for. Accessible routes shall be provided between all buildings and accessible site facilities. The accessible route shall be the most practical direct route between accessible building entries, accessible site facilities, and the accessible entry to the site. An accessible route shall connect to the public right-of-way and to at least one on-site or adjacent transit stop (if the area is served by transit). All facilities shall conform to, or exceed, the Americans with Disabilities Act (ADA) standards, including those included in the Uniform Building Code.*

**Staff Finding 97: Staff incorporates applicant findings. These criteria are met.**

L. *Signs.*

(...)

2. *The signs, graphics, and letter styles shall be designed to be compatible with surrounding development, to contribute to a sense of project identity, or, when appropriate, to reflect a sense of the history of the area and the architectural style.*
3. *The sign graphics and letter styles shall announce, inform, and designate particular areas or uses as simply and clearly as possible.*
4. *The signs shall not obscure vehicle driver's sight distance.*
5. *Signs indicating future use shall be installed on land dedicated for public facilities (e.g., parks, water reservoir, fire halls, etc.).*
6. *Signs and appropriate traffic control devices and markings shall be installed or painted in the driveway and parking lot areas to identify bicycle and pedestrian routes.*

**Staff Finding 98: Staff incorporates applicant findings. These criteria are met.**

M. *Utilities. The developer shall make necessary arrangements with utility companies or other persons or corporations affected for the installation of underground lines and facilities. Electrical lines and other wires, including but not limited to communication, street lighting, and cable television, shall be placed underground, as practical. The design standards of Tables 1 and 2 above, and of subsection 5.487 of the West Linn Municipal Code relative to existing high ambient noise levels shall apply to this section.*

**Staff Finding 99: The applicant shall make necessary arrangements with appropriate utilities to place them underground per Condition of Approval 4. Placing the overhead utilities underground is practical as the applicant will be reconstructing the street, which includes grading and trenching for additional utilities, thus providing the opportunity. Subject to the Condition of Approval, these criteria are met.**

(...)

O. *Refuse and recycling standards.*

1. *All commercial, industrial and multi-family developments over five units requiring Class II design review shall comply with the standards set forth in these provisions. Modifications to these provisions may be permitted if the Planning Commission determines that the changes are consistent with the purpose of these provisions and the City receives written evidence from the local franchised solid waste and recycling firm that they are in agreement with the proposed modifications.*
2. *Compactors, containers, and drop boxes shall be located on a level Portland cement concrete pad, a minimum of four inches thick, at ground elevation or other location compatible with the local franchise collection firm's equipment at the time of construction. The pad shall be designed to discharge surface water runoff to avoid ponding.*

**Staff Finding 100: Staff incorporates applicant findings. These criteria are met.**

3. *Recycling and solid waste service areas.*



- a. *Recycling receptacles shall be designed and located to serve the collection requirements for the specific type of material.*
- b. *The recycling area shall be located in close proximity to the garbage container areas and be accessible to the local franchised collection firm's equipment.*
- c. *Recycling receptacles or shelters located outside a structure shall have lids and be covered by a roof constructed of water and insect-resistive material. The maintenance of enclosures, receptacles and shelters is the responsibility of the property owner.*
- d. *The location of the recycling area and method of storage shall be approved by the local fire marshal.*
- e. *Recycling and solid waste service areas shall be at ground level and/or otherwise accessible to the franchised solid waste and recycling collection firm.*
- f. *Recycling and solid waste service areas shall be used only for purposes of storing solid waste and recyclable materials and shall not be a general storage area to store personal belongings of tenants, lessees, property management or owners of the development or premises.*
- g. *Recyclable material service areas shall be maintained in a clean and safe condition.*

**Staff Finding 101: Staff incorporates applicant findings. These criteria are met.**

- 4. *Special wastes or recyclable materials.*
  - a. *Environmentally hazardous wastes defined in ORS 466.005 shall be located, prepared, stored, maintained, collected, transported, and disposed in a manner acceptable to the Oregon Department of Environmental Quality.*
  - b. *Containers used to store cooking oils, grease or animal renderings for recycling or disposal shall not be located in the principal recyclable materials or solid waste storage areas. These materials shall be stored in a separate storage area designed for such purpose.*

**Staff Finding 102: Staff incorporates applicant findings. These criteria are met.**

- 5. *Screening and buffering.*
  - a. *Enclosures shall include a curbed landscape area at least three feet in width on the sides and rear. Landscaping shall include, at a minimum, a continuous hedge maintained at a height of 36 inches.*
  - b. *Placement of enclosures adjacent to residentially zoned property and along street frontages is strongly discouraged. They shall be located so as to conceal them from public view to the maximum extent possible.*
  - c. *All dumpsters and other trash containers shall be completely screened on all four sides with an enclosure that is comprised of a durable material such as masonry with a finish that is architecturally compatible with the project. Chain link fencing, with or without slats, will not be allowed.*

**Staff Finding 103: The applicant proposal includes a recycling/refuse enclosure on the west side of the new school building. The enclosure will be recessed into the building footprint and surrounded on three sides by the building and covered bicycle parking. The access to the**

enclosure will be screened with a solid gate. Landscape planters are provided on both sides of the access. These criteria are met.

6. *Litter receptacles.*

a. *Location. Litter receptacles may not encroach upon the minimum required walkway widths.*

b. *Litter receptacles may not be located within public rights-of-way except as permitted through an agreement with the City in a manner acceptable to the City Attorney or his/her designee.*

**Staff Finding 104: The applicant does not propose any litter receptacles in the public right-of-way. Any receptacles on the subject property will be located to not encroach upon required walkway widths. These criteria are met.**

#### 55.125 TRANSPORTATION ANALYSIS

*Certain development proposals required that a Traffic Impact Analysis (TIA) be provided which may result in modifications to the site plan or conditions of approval to address or minimize any adverse impacts created by the proposal. The purpose, applicability and standards of this analysis are found in CDC 85.170(B)(2).*

**Staff Finding 105: The applicant proposal does not require a TIA as it does not meet any of the conditions outlined in CDC 85.170.B.2.c. The applicant provided a transportation analysis (DKS Memorandum submitted as Exhibit C in applicant materials) that confirms there will be a reduction in total daily trips, a.m. peak hour trips, and p.m. peak hour trips because of a reduction in student capacity with the new school. These criteria are met.**

#### 55.170 EXCEPTIONS TO UNDERLYING ZONE, YARD, PARKING, SIGN PROVISIONS, AND LANDSCAPING PROVISIONS

A. *The Planning Director may grant an exception to the dimensional building setback or yard requirements in the applicable zone based on findings that the approval will satisfy the following criteria:*

1. *A minor exception that is not greater than 20 percent of the required setback.*
2. *A more efficient use of the site.*
3. *The preservation of natural features that have been incorporated into the overall design of the project.*
4. *No adverse affect to adjoining properties in terms of light, air circulation, noise levels, privacy, and fire hazard.*
5. *Safe vehicular and pedestrian access to the site and safe on-site vehicular and pedestrian circulation.*

**Staff Finding 106: The applicant is requesting an exception to the 20 foot front yard setback criteria for the R-10 zoning district. The applicant proposes a reduced setback of 17.1 feet, which is a 14.5 percent reduction. The subject property is 6.19 acres and available space on this school site is limited. The reduction allows for a more efficient use of the site because the play and buffer areas on the rear of the building can be slightly larger, while also preserving**

**77 percent of the significant tree canopy coverage on the subject property. The exception will allow for greater buffering for neighboring properties. In addition, because of the 90 degree bend in the street at the building entrance, the effective front setback is consistent with the normal 20-foot setback. The properties on the opposite side of the street will not experience any visual encroachment from the minor reduction in the front yard setback. As demonstrated in the site plan, the front entrance orientation and distance to the street will help enhance pedestrian access by establishing a direct route to the front entry and eliminating any potential vehicle-pedestrian conflicts in this area. Subject to approval of the exception, these criteria are met.**

*B. The Planning Director may grant an exception to the off-street parking dimensional and minimum number of space requirements in the applicable zone so long as the following criteria are met:*

- 1. The minor exception is not greater than 10 percent of the required parking;*
- 2. The application is for a use designed for a specific purpose which is intended to be permanent in nature (for example, a nursing home) and which has a low demand for off-street parking; or*
- 3. There is an opportunity for sharing parking and there is written evidence that the property owners are willing to enter into a legal agreement; or*
- 4. Public transportation is available to the site reducing the standards and will not adversely affect adjoining uses, and there is a community interest in the preservation of particular natural feature(s) of the site which make it in the public interest to grant an exception to parking standards.*

**Staff Finding 107: The applicant is requesting an exception for a reduction in minimum required parking spaces. The minimum parking requirements for the applicant proposal is 97 spaces (see Staff Finding 14) and they seek an exemption to reduce the parking by 9.3 percent to 88 parking spaces. The school is a permanent use, which does not have a high daily demand with 35 staff and a student body that does not drive. Parking demand for special school events will always exceed on-site parking available at virtually any school. The parking represents a significant increase compared to the current situation. The opportunity for shared parking is not applicable in this case. Public transportation, in the form of school buses, is available to the site. In addition, substantial improvements will be made to further encourage walking and bicycling to school. Finally, the required parking could be provided in the southeastern portion of the site, but it would require removal of several additional trees. These criteria are met.**

*C. The Planning Director may grant an exception to the sign dimensional requirements in the applicable zone when the following criteria are met:*

- 1. The minor exception is not greater than 10 percent of the required applicable dimensional standard for signs;*
- 2. The exception is necessary for adequate identification of the use on the property; and*
- 3. The sign will be compatible with the overall site plan, the structural improvements, and with the structures and uses on adjoining properties.*

- D. *The Planning Director may grant an exception to the landscaping requirements in the applicable zone based on findings that the following criteria will be met:*
1. *A minor exception that is not greater than 10 percent of the required landscaped area.*
  2. *A more efficient use of the site.*
  3. *The preservation of natural features that have been incorporated into the overall design of the project.*
  4. *No adverse effect to adjoining property.*

**Staff Finding 108: The applicant is not requesting any exceptions for signs or landscaping. These criteria do not apply.**

## **XI. CHAPTER 60, CONDITIONAL USES**

### *60.070 APPROVAL STANDARDS AND CONDITIONS*

A. *The Planning Commission shall approve, approve with conditions, or deny an application for a conditional use, except for a manufactured home subdivision in which case the approval standards and conditions shall be those specified in CDC 36.030, or to enlarge or alter a conditional use based on findings of fact with respect to each of the following criteria:*

1. *The site size and dimensions provide:*
  - a. *Adequate area for the needs of the proposed use; and*
  - b. *Adequate area for aesthetic design treatment to mitigate any possible adverse effect from the use on surrounding properties and uses.*

**Staff Finding 109: Staff incorporates applicant findings. These criteria are met.**

2. *The characteristics of the site are suitable for the proposed use considering size, shape, location, topography, and natural features.*

**Staff Finding 110: Staff incorporates applicant findings. These criteria are met.**

3. *The granting of the proposal will provide for a facility that is consistent with the overall needs of the community.*

**Staff Finding 111: Staff incorporates applicant findings. These criteria are met.**

4. *Adequate public facilities will be available to provide service to the property at the time of occupancy.*
5. *The applicable requirements of the zone are met, except as modified by this chapter.*
6. *The supplementary requirements set forth in Chapters 52 to 55 CDC, if applicable, are met.*
7. *The use will comply with the applicable policies of the Comprehensive Plan.*

**Staff Finding 112: Staff incorporates applicant findings. These criteria are met.**

*B. An approved conditional use or enlargement or alteration of an existing conditional use shall be subject to the development review provisions set forth in Chapter 55 CDC.*

**Staff Finding 113: Please see Staff Findings 68 to 108. These criteria are met.**

*C. The Planning Commission may impose conditions on its approval of a conditional use which it finds are necessary to assure the use is compatible with other uses in the vicinity. These conditions may include, but are not limited to, the following:*

*1. Limiting the hours, days, place, and manner of operation.*

**Staff Finding 114: Staff incorporates applicant findings. These criteria are met.**

*2. Requiring design features which minimize environmental impacts such as noise, vibration, air pollution, glare, odor, and dust.*

**Staff Finding 115: Staff incorporates applicant findings. These criteria are met.**

*3. Requiring additional setback areas, lot area, or lot depth, or width.*

**Staff Finding 116: Staff incorporates applicant findings. These criteria are met.**

*4. Limiting the building height, size or lot coverage, or location on the site.*

**Staff Finding 117: Staff incorporates applicant findings. These criteria are met.**

*5. Designating the size, number, location and design of vehicle access points.*

**Staff Finding 118: Staff incorporates applicant findings. These criteria are met.**

*6. Requiring street right-of-way to be dedicated and the street to be improved including all steps necessary to address future street improvements identified in the adopted Transportation System Plan.*

**Staff Finding 119: Staff incorporates applicant findings. These criteria are met.**

*7. Requiring participation in making the intersection improvement or improvements identified in the Transportation System Plan when a traffic analysis (compiled as an element of a conditional use application for the property) indicates the application should contribute toward.*

**Staff Finding 120: Staff incorporates applicant findings. These criteria are met.**

*8. Requiring landscaping, screening, drainage, and surfacing of parking and loading areas.*

**Staff Finding 121: Staff incorporates applicant findings. These criteria are met.**

9. *Limiting the number, size, location, height, and lighting of signs.*

**Staff Finding 122: Staff incorporates applicant findings. These criteria are met.**

10. *Limiting or setting standards for the location and intensity of outdoor lighting.*

**Staff Finding 123: Staff incorporates applicant findings. These criteria are met.**

11. *Requiring berming, screening, or landscaping and the establishment of standards for their installation and maintenance.*

**Staff Finding 124: Staff incorporates applicant findings. These criteria are met.**

12. *Requiring and designating the size, height, location, and materials for fences.*

**Staff Finding 125: Staff incorporates applicant findings. These criteria are met.**

13. *Requiring the protection and preservation of existing trees, soils, vegetation, watercourses, habitat areas, and drainage areas.*

**Staff Finding 126: Staff incorporates applicant findings. These criteria are met.**

D. *Aggregate extraction uses shall also be subject to the provisions of ORS [541.605](#).*

E. *The Historic Review Board shall review an application for a conditional use, or to enlarge a conditional use on a property designated as a historic resource, based on findings of fact that the use will:*

1. *Preserve or improve a historic resource which would probably not be preserved or improved otherwise; and*
2. *Utilize existing structures rather than new structures.*

**Staff Finding 127: Staff incorporates applicant findings. These criteria are met.**

## **XII. CHAPTER 75, VARIANCES AND SPECIAL WAIVERS**

### **75.020 CLASSIFICATION OF VARIANCES**

A. *Class I Variance. Class I variances provide minor relief from certain code provisions where it can be demonstrated that the modification will not harm adjacent properties, and it conforms with any other code requirements. Class I variances are allowed for the following code provisions:*

1. *Required Yard and Minimum Lot Dimensional Requirements. (...)*
2. *Off-street parking dimensional and minimum number of space requirements may be modified up to 10 percent (...)*

3. *Dimensional sign requirements may be modified up to 10 percent (...)*
4. *Landscaping requirements in the applicable zone may be modified up to 10 percent (...)*
- B. *Class II Variance. Class II variances may be utilized when strict application of code requirements would be inconsistent with the general purpose of the CDC and would create a burden upon a property owner with no corresponding public benefit. A Class II variance will involve a significant change from the code requirements and may create adverse impacts on adjacent property or occupants. It includes any variance that is not classified as a Class I variance or special waiver.*

**Staff Finding 128: The applicant is requesting three Class II Variances to allow on-site parking spaces to be located beyond the 200-foot maximum distance to the building entrance as required in CDC Section 46.070; to allow on-site bike parking spaces to be located beyond the 50-foot maximum distance to the building entrance as required in CDC Section 46.150; and to allow a wall sign of approximately 42 square feet where a maximum of 18 feet is required in CDC Section 52.300. These criteria are met.**

1. *Class II Variance Approval Criteria. The approval authority may impose appropriate conditions to ensure compliance with the criteria. The appropriate approval authority shall approve a variance request if all the following criteria are met and corresponding findings of fact prepared.*
  - a. *The variance is the minimum variance necessary to make reasonable use of the property. To make this determination, the following factors may be considered, together with any other relevant facts or circumstances:*
    - 1) *Whether the development is similar in size, intensity and type to developments on other properties in the City that have the same zoning designation.*

**Staff Finding 129: The applicant proposal is to build a new primary school on an existing school site. The proposal requires a conditional use, as do all schools in residential zones. West Linn contains four primary, one middle, and one high school, all in residential zones and similar in size and intensity. These criteria are met.**

- 2) *Physical characteristics of the property such as lot size or shape, topography, or the existence of natural resources.*

**Staff Finding 130: Staff incorporates applicant findings. This criterion is met.**

- 3) *The potential for economic development of the subject property.*

**Staff Finding 131: Staff incorporates applicant findings. This criterion is met.**

- b. *The variance will not result in violation(s) of any other code standard, and the variance will meet the purposes of the regulation being modified.*

**Staff Finding 132:** The proposed variances will not result in violations of other code standards. Parking lot design and dimensional requirements have been met, as well as bicycle parking standards outside of the variance request. Sign standards for the proposed free standing sign have been met. The vehicle parking distance variance will meet the purpose of the code as, for a facility like a school, it is extremely difficult to get all parking spaces within 200 feet of the main entrance. This could be possible, but it would mean locating the main entrance a significant distance from the street and surrounding it with parking. The western parking lot could be brought closer to compliance, but it would mean that the sports field would be removed from the school by a significant distance. The school is different from a commercial development, which would have multiple building entrances and the ability to locate all spaces within 200 feet of at least one entrance. The bicycle parking distance variance will meet the purpose of the code as bicycle use at primary schools is relative low, and it will tend to be somewhat higher during good weather. With this in mind, 20 of the required spaces are proposed within 50 feet of the building entrance. The remaining spaces are covered, but approximately 130 feet from the entrance. Unless the proposed canopy is made exceptionally large, providing the required covered bike spaces near the entrance would interfere with pedestrian access in and out of the school. The proposed arrangement offers a reasonable combination of convenience and secure bike parking. The maximum sign area variance will meet the purpose of the code as these maximum requirements are to ensure signage, no matter the use of the building, does not dominate the façade. The proposed entryway on-wall sign will only be 3.5 percent of the front entryway façade. This criterion is met.

*c. The need for the variance was not created by the applicant and/or owner requesting the variance.*

**Staff Finding 133:** Staff incorporates applicant findings. This criterion is met.

*d. If more than one variance is requested, the cumulative effect of the variances results in a project that is consistent with the overall purpose of the zone.*

**Staff Finding 134:** Staff incorporates applicant findings. This criterion is met.

### ***XIII. CHAPTER 92, REQUIRED IMPROVEMENTS***

#### ***92.010 PUBLIC IMPROVEMENTS FOR ALL DEVELOPMENT***

*The following improvements shall be installed at the expense of the developer and meet all City codes and standards:*

- A. Streets within subdivisions.*
- B. Extension of streets to subdivisions*
- C. Local and minor collector streets*
- D. Monuments*



**Staff Finding 135: The applicant shall install improvements to meet the West Linn Public Works Standards per Conditions of Approval 2 and 3. Subject to the Conditions of Approval, this criterion is met.**

*E. Surface drainage and storm sewer system. A registered civil engineer shall prepare a plan and statement which shall be supported by factual data that clearly shows that there will be no adverse impacts from increased intensity of runoff off site of a 100-year storm, or the plan and statement shall identify all off-site impacts and measures to mitigate those impacts commensurate to the particular land use application. Mitigation measures shall maintain pre-existing levels and meet buildout volumes, and meet planning and engineering requirements.*

**Staff Finding 136: The applicant has submitted a Preliminary Stormwater Report that complies with City of West Linn Public Works Standards. The applicant shall install improvements to meet the Standards per Condition of Approval 2, including the proposed stormwater facility and overflow pipe the length of Bittner Street to connect at the existing infrastructure at Long Street. Subject to the Conditions of Approval, this criterion is met.**

*F. Sanitary sewers*

*(...)*

*G. Water system*

*(...)*

*H. Sidewalks.*

*(...)*

**Staff Finding 139: The applicant has collaborated with the City Engineer to design the sanitary sewer, water system, and sidewalks to comply with City of West Linn Public Works Standards. The applicant shall install all improvements to meet the Standards per Conditions of Approval 2, 3, 4, and 12. Subject to the Conditions of Approval, this criterion is met.**

*I. Bicycle routes.*

*J. Street name signs.*

*K. Dead-end street signs.*

*L. Signs indicating future use.*

*M. Street lights.*

**Staff Finding 140: The applicant shall comply with the requirements and install improvements, including street lighting per Plan Sheet LU4.02, to meet the West Linn Public Works Standards. These criteria are met.**

*N. Utilities.*

*O. Curb cuts and driveways.*

*P. Street trees.*

*Q. Joint mailbox facilities*

**Staff Finding 141: The applicant shall comply with the requirements and install improvements to meet the West Linn Public Works Standards. These criteria are met.**

*92.030 IMPROVEMENT PROCEDURES*

(...)

**Staff Finding 142: The applicant shall comply with the requirements and install improvements to meet the West Linn Public Works Standards. These criteria are met.**

***XIV. CHAPTER 96, STREET IMPROVEMENT CONSTRUCTION***

*96.010 CONSTRUCTION REQUIRED*

(...)

*C. Replacement of an existing building.*

*1. Building permits shall not be issued for the replacement of any existing building or structure which results in an increase in size unless:*

*a. The applicant for said building permit agrees to construct street improvements; and*

*b. The City Manager or the Manager's designee determines the replacement is sufficiently increased in size to cause construction of street improvements.*

(...)

**Staff Finding 143: The applicant proposal includes construction of half-street improvements along portions of Bittner and Oxford Streets that are adjacent to the subject property. In addition, Public Works shall coordinate with the applicant to voluntarily complete half street improvements on the opposite side of the streets, including pavement improvements, curbs, planter strips, street trees, street lights, sidewalks, pedestrian crossings, and street storm drainage. The applicant will construct both required and voluntary improvements and the City will reimburse the applicant for voluntary improvement costs. While this is a voluntary agreement, the completion is required to provide necessary pedestrian safety and mobility improvement to the subject property and surrounding properties. The applicant has agreed to construct full-street improvements with the City providing reimbursement for the other half of the street improvements, per Condition of Approval 3. Subject to the Condition of Approval, this criterion is met.**

*96.020 STANDARDS*

*Street improvements shall be installed according to the City standards and shall be completed prior to the issuance of any occupancy permit for the new or remodeled structure or building. In unimproved areas of the City, the City Engineer may grant a time extension of the provisions of this section; provided, that the applicant provides sufficient security in amount and quantity satisfactory to the City Attorney to assure payment of such improvement costs*

**Staff Finding 144: The applicant proposal includes construction of half-street improvements along portions of Bittner and Oxford Streets that are adjacent to the subject property. The**

applicant has agreed to construct full-street improvements with the City providing reimbursement for the other half of the street improvements, per Condition of Approval 3. Subject to the Condition of Approval, this criterion is met.

#### **XV. CHAPTER 99, PROCEDURES FOR DECISION MAKING: QUASI-JUDICIAL**

##### *99.030 APPLICATION PROCESS: WHO MAY APPLY, PRE-APPLICATION CONFERENCE, REQUIREMENTS, REFUSAL OF APPLICATION, FEES*

(...)

B. *Pre-application conferences.*

1. *Subject to subsection (B)(4) of this section, a pre-application conference is required for, but not limited to, each of the following applications:*

(...)

d. *Conditional uses;*

e. *Design review (Class I and Class II);*

(...)

o. *Variances;*

(...)

**Staff Finding 145: The applicant attended a pre-application conference with City staff on May 7, 2015. These criteria are met.**

##### *99.038 NEIGHBORHOOD CONTACT REQUIRED FOR CERTAIN APPLICATIONS*

*Prior to submittal of an application for any subdivision, conditional use permit, (...)*

**Staff Finding 146: The applicant had neighborhood contact by attending the Sunset Neighborhood Meeting on November 10, 2015. Required documentation pertaining to this meeting are included as Exhibit B of the applicant submittal. These criteria are met.**

##### *99.060 APPROVAL AUTHORITY*

B. *Planning Commission authority. The Planning Commission shall have the authority to:*

(...)

2. *Approve, deny, or approve with conditions the following applications:*

(...)

b. *A conditional use (Chapter 60 CDC).*

(...)

e. *Class II variance or special waiver (Chapter 75 CDC).*

(...)

h. *Design review, Class II (Chapter 55 CDC).*

(...)

**Staff Finding 147: The applicant proposal will be heard by the Planning Commission at a public hearing scheduled for March 16, 2016.**

*99.080 NOTICE*

*Notice shall be given in the following ways:*

A. *Class A Notice. (...)*

**Staff Finding 148: The applicant proposal has been properly noticed by the City. Please see Staff Report for the Planning Commission Exhibit PC-1 below. These criteria are met**

# PC-1 AFFIDAVIT AND NOTICE PACKET

**AFFIDAVIT OF NOTICE**

We, the undersigned do hereby certify that, in the interest of the party (parties) initiating a proposed land use, the following took place on the dates indicated below:

**GENERAL**

File No. WP-15-03/DR-15-17/VAR-15-01/02/03 Applicant's Name WLWV School District  
Development Name \_\_\_\_\_  
Scheduled Meeting/Decision Date 3-16-16

**NOTICE:** Notices were sent at least 20 days prior to the scheduled hearing, meeting, or decision date per Section 99.080 of the Community Development Code. (check below)

**TYPE A**

- A. The applicant (date) 2-25-16 (signed) S. Skroyer
- B. Affected property owners (date) 2-25-16 (signed) S. Skroyer
- C. School District/Board (date) 2-25-16 (signed) S. Skroyer
- D. Other affected gov't. agencies (date) 2-25-16 (signed) S. Skroyer
- E. Affected neighborhood assns. (date) 2-25-16 (all) (signed) S. Skroyer
- F. All parties to an appeal or review (date) \_\_\_\_\_ (signed) \_\_\_\_\_

At least 10 days prior to the scheduled hearing or meeting, notice was published/posted:

Tidings (published date) 3-3-16 (signed) S. Skroyer  
City's website (posted date) 2-25-16 (signed) S. Skroyer

**SIGN**

At least 10 days prior to the scheduled hearing, meeting or decision date, a sign was posted on the property per Section 99.080 of the Community Development Code.

(date) 3-2-2016 (signed) Dan S Wynn

**NOTICE:** Notices were sent at least 14 days prior to the scheduled hearing, meeting, or decision date per Section 99.080 of the Community Development Code. (check below)

**TYPE B** \_\_\_\_\_

- A. The applicant (date) \_\_\_\_\_ (signed) \_\_\_\_\_
- B. Affected property owners (date) \_\_\_\_\_ (signed) \_\_\_\_\_
- C. School District/Board (date) \_\_\_\_\_ (signed) \_\_\_\_\_
- D. Other affected gov't. agencies (date) \_\_\_\_\_ (signed) \_\_\_\_\_
- E. Affected neighborhood assns. (date) \_\_\_\_\_ (signed) \_\_\_\_\_

Notice was posted on the City's website at least 10 days prior to the scheduled hearing or meeting.

Date: \_\_\_\_\_ (signed) \_\_\_\_\_

**STAFF REPORT** mailed to applicant, City Council/Planning Commission and any other applicable parties 10 days prior to the scheduled hearing.

(date) 3-3-2016 (signed) Dan S Wynn

**FINAL DECISION** notice mailed to applicant, all other parties with standing, and, if zone change, the County surveyor's office.

(date) \_\_\_\_\_ (signed) \_\_\_\_\_

**CITY OF WEST LINN  
PLANNING COMMISSION  
PUBLIC HEARING NOTICE  
FILE NO. CUP-15-03/DR-15-17/VAR-15-01/02/03**

The West Linn Planning Commission is scheduled to hold a public hearing, on **Wednesday, March 16, 2016, starting at 6:30 p.m.** in the Council Chambers of City Hall, 22500 Salamo Road, West Linn, to consider a request for a Conditional Use Permit, Class II Design Review, and three Class II Variances for the proposed new Sunset Primary School at 2351 Oxford Street.

Criteria applicable to the requested Conditional Use Permit, Class II Design Review, and Class II Variances (parking location, bicycle parking location, sign area) are in CDC Chapters 11, 38, 41, 42, 44, 46, 48, 52, 54, 55, 60, 75, 92, 96, and 99. Approval or disapproval of the request by the Planning Commission will be based upon these criteria and these criteria only. At the hearing, it is important that comments relate specifically to the applicable criteria listed.

You have been notified of this proposal because County records indicate that you own property within 500 feet of the affected site on Clackamas County Assessor's Map 2S-1E-25 DC, Tax Lots 3700, 5800, 6100, 6200, and 6300 or as required by Chapter 99 of the CDC.

The complete application in the above noted file is available for inspection at no cost at City Hall or via the web site at <http://westlinnoregon.gov/planning/2351-oxford-street-conditional-use-permit-class-ii-design-review-and-3-variances-construct> or copies can be obtained for a minimal charge per page. At least ten days prior to the hearing, a copy of the staff report will be available for inspection. For further information, please contact Associate Planner Darren Wyss at [dwyss@westlinnoregon.gov](mailto:dwyss@westlinnoregon.gov) or 503-722-5512. Alternately, visit City Hall, 22500 Salamo Road, West Linn, OR 97068.

The hearing will be conducted in accordance with the rules of Section 99.170 of the CDC. Anyone wishing to present written testimony on this proposed action may do so in writing prior to, or at the public hearing. Oral testimony may be presented at the public hearing. At the public hearing, the Planning Commission will receive a staff presentation, and invite both oral and written testimony. The Planning Commission may continue the public hearing to another meeting to obtain additional information, leave the record open for additional evidence, arguments, or testimony, or close the public hearing and take action on the application as provided by state law. **It is important to provide all evidence, both oral and written, to the Planning Commission. Generally, the City Council will not be able to accept additional evidence if there is an appeal of this application.** Failure to raise an issue in person or by letter at some point prior to the close of the hearing, or failure to provide sufficient specificity to afford the decision maker an opportunity to respond to the issue, precludes an appeal to the Land Use Board of Appeals (LUBA) based on that issue.

# 2351 Oxford Street Notification Map

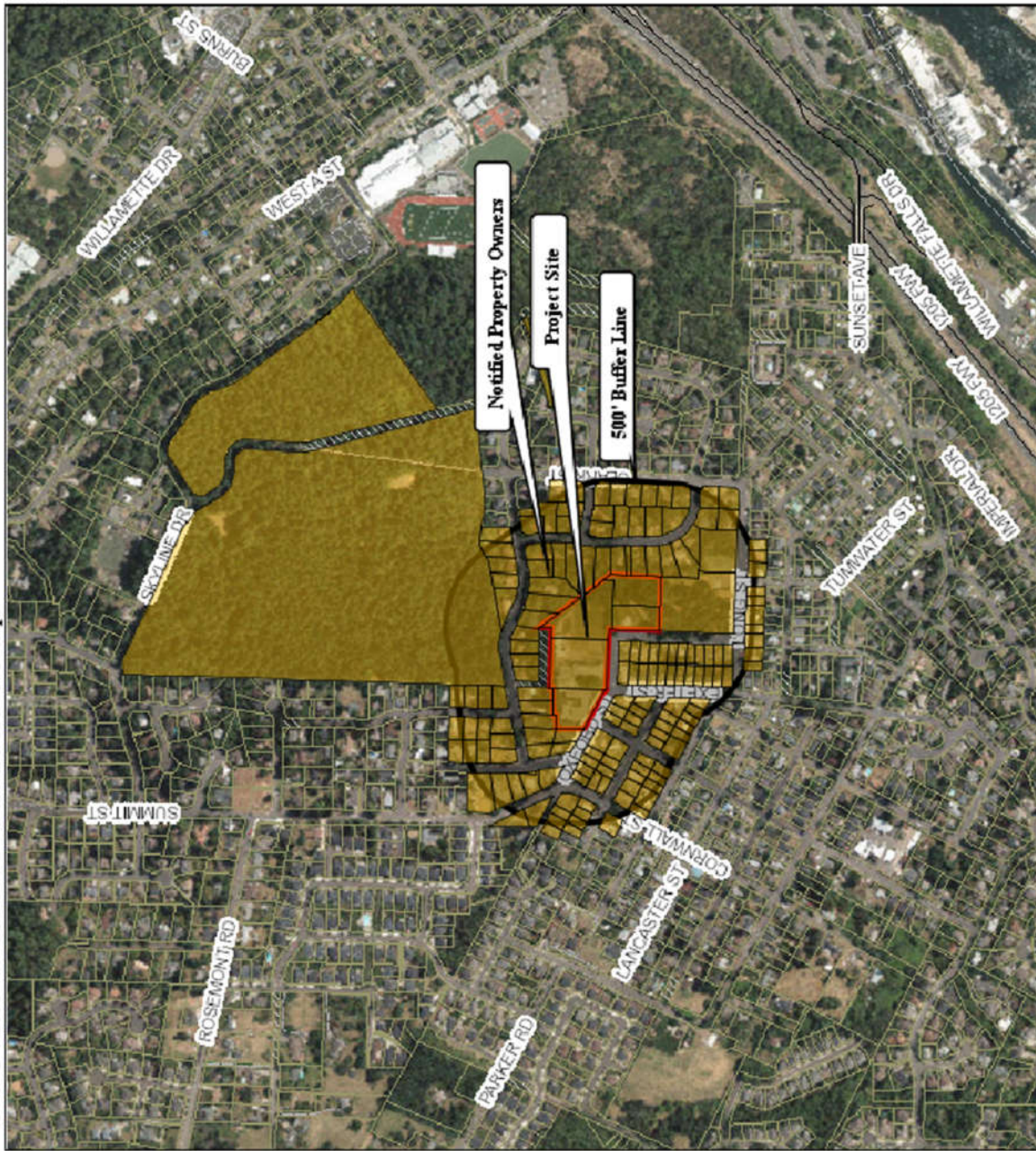

Scale: 1:3,600 - 1 in = 600 ft  
Scale is based on 8-1/2 x 11 paper size



Map created by: SSHROYER  
Date Created: 01-Dec-15 09:41 AM

**WEST LINN GIS**

DISCLAIMER: This product is for informational purposes and may not have been prepared for, or be suitable for, legal, engineering, or surveying purposes. Users of this information should review or consult the primary data and information sources to ascertain the usability of the information. Source: West Linn GIS (Geographic Information System) MapOptix.





## **CITY COUNCIL PUBLIC HEARING**

### **PROJECT #**

**CUP-15-03/DR-15-17/VAR-15-01/VAR-15-02/VAR-15-03  
MAIL: 2/25/16 TIDINGS: 3/3/16**

### **CITIZEN CONTACT INFORMATION**

To lessen the bulk of agenda packets, land use application notice, and to address the worries of some City residents about testimony contact information and online application packets containing their names and addresses as a reflection of the mailing notice area, this sheet substitutes for the photocopy of the testimony forms and/or mailing labels. A copy is available upon request.

**CITY OF WEST LINN  
PLANNING COMMISSION  
PUBLIC HEARING NOTICE  
FILE NO. CUP-15-03/DR-15-17/VAR-15-01/02/03**

The West Linn Planning Commission is scheduled to hold a public hearing, on **Wednesday, March 16, 2016, starting at 6:30 p.m.** in the Council Chambers of City Hall, 22500 Salamo Road, West Linn, to consider a request for a Conditional Use Permit, Class II Design Review, and three Class II Variances for the proposed new Sunset Primary School at 2351 Oxford Street (Clackamas County Assessor's Map 2S-1E-25 DC, Tax Lots 3700, 5800, 6100, 6200, and 6300).

Criteria applicable to the requested Conditional Use Permit, Class II Design Review, and Class II Variances (parking location, bicycle parking location, sign area) are in CDC Chapters 11, 38, 41, 42, 44, 46, 48, 52, 54, 55, 60, 75, 92, 96, and 99. Approval or disapproval of the request by the Planning Commission will be based upon these criteria and these criteria only. At the hearing, it is important that comments relate specifically to the applicable criteria listed.

The complete application in the above noted file is available for inspection at no cost at City Hall or via the web site at <http://westlinnoregon.gov/planning/2351-oxford-street-conditional-use-permit-class-ii-design-review-and-3-variances-construct> or copies can be obtained for a minimal charge per page. At least ten days prior to the hearing, a copy of the staff report will be available for inspection. For further information, please contact Associate Planner Darren Wyss at [dwyss@westlinnoregon.gov](mailto:dwyss@westlinnoregon.gov) or 503-722-5512. Alternately, visit City Hall, 22500 Salamo Road, West Linn, OR 97068.

The hearing will be conducted in accordance with the rules of Section 99.170 of the CDC. Anyone wishing to present written testimony on this proposed action may do so in writing prior to, or at the public hearing. Oral testimony may be presented at the public hearing. At the public hearing, the Planning Commission will receive a staff presentation, and invite both oral and written testimony. The Planning Commission may continue the public hearing to another meeting to obtain additional information, leave the record open for additional evidence, arguments, or testimony, or close the public hearing and take action on the application as provided by state law. **It is important to provide all evidence, both oral and written, to the Planning Commission. Generally, the City Council will not be able to accept additional evidence if there is an appeal of this application.** Failure to raise an issue in person or by letter at some point prior to the close of the hearing, or failure to provide sufficient specificity to afford the decision maker an opportunity to respond to the issue, precludes an appeal to the Land Use Board of Appeals (LUBA) based on that issue.

Publish: West Linn Tidings, March 3, 2016

## PC-2 COMPLETENESS LETTER



## CITY OF West Linn

February 1, 2016

Tim Woodley  
WLWV School District  
2755 SW Borland Rd.  
Tualatin, OR 97062

SUBJECT: CUP-15-03/DR-15-17/VAR-15-01/VAR-15-02/VAR-15-03 application for Conditional Use Permit, Class II Design Review, and three Variances to construct a new Sunset Primary School on existing school site at 2351 Oxford Street

Dear Tim:

You submitted this application on December 2, 2015. The Planning and Engineering Departments found that this application was incomplete on December 18, 2015. Additional information was subsequently provided on January 7, 2016 and the application has now been deemed **complete**. The city has 120 days to exhaust all local review; that period ends May 31, 2016.

Please be aware that a determination of a complete application does not guarantee a recommendation of approval from staff for your proposal as submitted – it signals that staff believes you have provided the necessary information for the Planning Commission to render a decision on your proposal.

We are determining with our Planning Commission, the best date for which to schedule this project for a public hearing. You will receive written notice of the actual hearing date at least 20 days prior to the hearing.

Please contact me at 503-722-5512, or by email at [dwyss@westlinnoregon.gov](mailto:dwyss@westlinnoregon.gov) if you have any questions or comments.

Sincerely,

A handwritten signature in blue ink that reads "Darren S. Wyss". The signature is fluid and cursive, with the first name being the most prominent.

Darren Wyss  
Associate Planner

**PC-3 APPLICANT'S SUBMITTAL**



### DEVELOPMENT REVIEW APPLICATION

For Office Use Only		
STAFF CONTACT	PROJECT NO(S). <u>CU-15-03 / DR-15-17 / VA-15-01 / 02/03</u>	
NON-REFUNDABLE FEE(S) <u>6300</u>	REFUNDABLE DEPOSIT(S) <u>24500</u>	TOTAL <u>30800</u>

**Type of Review (Please check all that apply):**

- |   |   |  |
|---|---|--|
| <input type="checkbox"/> Annexation (ANX)                                 | <input type="checkbox"/> Historic Review                                  | <input type="checkbox"/> Subdivision (SUB)                                       |
| <input type="checkbox"/> Appeal and Review (AP) * <u>D F</u>              | <input type="checkbox"/> Legislative Plan or Change                       | <input type="checkbox"/> Temporary Uses *  |
| <input checked="" type="checkbox"/> Conditional Use (CUP) <u>4500/200</u> | <input type="checkbox"/> Lot Line Adjustment (LLA) */**                   | <input type="checkbox"/> Time Extension *  |
| <input checked="" type="checkbox"/> Design Review (DR) <u>CLASS II F</u>  | <input type="checkbox"/> Minor Partition (MIP) (Preliminary Plat or Plan) | <input checked="" type="checkbox"/> Variance (VAR) <u>CLASS II F</u> <u>5800</u> |
| <input type="checkbox"/> Easement Vacation <u>2000</u> <u>360</u>         | <input type="checkbox"/> Non-Conforming Lots, Uses & Structures           | <input type="checkbox"/> Water Resource Area Protection/Single Lot (WAP)         |
| <input type="checkbox"/> Extraterritorial Ext. of Utilities               | <input type="checkbox"/> Planned Unit Development (PUD)                   | <input type="checkbox"/> Water Resource Area Protection/Wetland (WAP)            |
| <input type="checkbox"/> Final Plat or Plan (FP)                          | <input type="checkbox"/> Pre-Application Conference (PA) */**             | <input type="checkbox"/> Willamette & Tualatin River Greenway (WRG)              |
| <input type="checkbox"/> Flood Management Area                            | <input type="checkbox"/> Street Vacation                                  | <input type="checkbox"/> Zone Change   |
| <input type="checkbox"/> Hillside Protection & Erosion Control            |   |  |

Home Occupation, Pre-Application, Sidewalk Use, Sign Review Permit, and Temporary Sign Permit applications require different or additional application forms, available on the City website or at City Hall.

<b>Site Location/Address:</b> <u>2351 OXFORD STREET</u>	Assessor's Map No.: <u>2S1 25DC</u>
	Tax Lot(s): <u>600, 3700, 5800, 6200, 6300</u>
	Total Land Area: <u>6.19 ac</u>

**Brief Description of Proposal:** TO BUILD A NEW PRIMARY SCHOOL ON THE SAME SITE.

<b>Applicant Name:</b> <u>TIM WOODLEY</u> <small>(please print)</small>	Phone: <u>503.673.7976</u>
Address: <u>West Linn-Wilsonville Sch. Dist., 2755 SW Borland Rd.</u>	Email: <u>woodleyt@wlwv.k12.or.us</u>
City State Zip: <u>TUALATIN, OR 97062</u>	

<b>Owner Name (required):</b> <u>SAME</u> <small>(please print)</small>	Phone:
Address:	Email:
City State Zip:	

<b>Consultant Name:</b> <u>KEITH LIDEN</u> <small>(please print)</small>	Phone: <u>503.757.5501</u>
Address: <u>319 SW Washington St., Suite 914</u>	Email: <u>keith.liden@gmail.com</u>
City State Zip: <u>PORTLAND, OR 97204</u>	

- All application fees are non-refundable (excluding deposit). Any overruns to deposit will result in additional billing.
- The owner/applicant or their representative should be present at all public hearings.
- A denial or approval may be reversed on appeal. No permit will be in effect until the appeal period has expired.
- Three (3) complete hard-copy sets (single sided) of application materials must be submitted with this application. One (1) complete set of digital application materials must also be submitted on CD in PDF format. If large sets of plans are required in application please submit only two sets.

\* No CD required / \*\* Only one hard-copy set needed

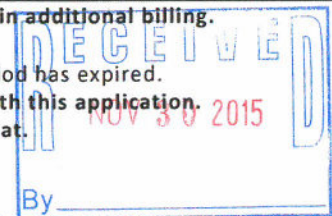

The undersigned property owner(s) hereby authorizes the filing of this application, and authorizes on site review by authorized staff. I hereby agree to comply with all code requirements applicable to my application. Acceptance of this application does not infer a complete submittal. All amendments to the Community Development Code and to other regulations adopted after the application is approved shall be enforced where applicable. Approved applications and subsequent development is not vested under the provisions in place at the time of the initial application.

Applicant's signature	Date	Owner's signature (required)	Date
		<u>Tim Woodley</u>	<u>11-12-15</u>

# SUNSET PRIMARY SCHOOL

## Conditional Use, Design Review, Director's Exception, and Class II Variances

*January 7, 2015*

### TABLE OF CONTENTS

APPLICATION SUMMARY	1
GENERAL INFORMATION	1
BACKGROUND INFORMATION	3
COMMUNITY ENGAGEMENT	4
PROPOSED IMPROVEMENTS	5
APPLICABLE CRITERIA – CONDITIONAL USE	14
APPLICABLE CRITERIA – DESIGN REVIEW	20
APPLICABLE CRITERIA – DIRECTOR'S EXCEPTION	31
APPLICABLE CRITERIA – CLASS II VARIANCE	32
CONCLUSION	34

#### EXHIBITS

- Exhibit A – Property Information
- Exhibit B – Neighborhood Meeting
- Exhibit C - Sunset Primary School Transportation Analysis and Safe Routes to School Plan, DKS
- Exhibit D – Arborist Report
- Exhibit E - Noise Study
- Exhibit F – Preliminary Storm Water Drainage Report

## APPLICATION SUMMARY

For approval of the following three related applications:

- Conditional Use approval to construct a new primary school and related facilities on the existing Sunset Primary School site.
- Design Review approval for the new school and facilities.
- Director's Exception as provided in West Linn Community Development Code (CDC) Section 55.170 A. to allow a 17.1-foot front yard setback where 20 feet is required in CDC Section 11.070.
- Director's Exception approval per CDC Section 55.170 B. to allow 88 parking spaces where 97 spaces are required.
- Class II Variance to allow on-site parking spaces to be located beyond the 200-foot maximum distance to the building entrance as required in CDC Section 46.070.
- Class II Variance to allow on-site bike parking spaces to be located beyond the 50-foot maximum distance to the building entrance as required in CDC Section 46.150.
- A Class II Variance to allow a wall sign of approximately 42 square feet where a maximum of 18 feet is required in CDC Section 52.300.

## GENERAL INFORMATION

### Location

Sunset Primary School property - 2351 Oxford Street (2S 1E Section 25 DC, Tax Lots 600, 3700, 5800, 6200, and 6300). Its location is shown in Figure 1.

### Comprehensive Plan and Zoning Designations

The Comprehensive Plan designation is Low Density Residential.

Consistent with the Comprehensive Plan, the property is zoned Single Family Residential Detached (R-10).

### Property Owner and Applicant's Representative

West Linn-Wilsonville School District 3JT  
Tim Woodley, Director of Operations  
2755 SW Borland Road  
Tualatin, OR 97062  
Phone: 503.673.7976  
E-mail: [woodleyt@wlwv.k12.or.us](mailto:woodleyt@wlwv.k12.or.us)

Keith Liden, AICP  
Bainbridge  
319 SW Washington Street, Suite 914  
Portland, OR 97204  
Phone: 503.757.5501  
E-mail: [keith.liden@gmail.com](mailto:keith.liden@gmail.com)



## Applicant's Design Team

### Architect

Bill Conboy, AIA  
Dull Olsen Weekes/IBI Group  
903 SW Stark Street  
Portland, OR 97205  
Phone: 503.226.6950  
E-mail: [bill.conboy@IBIGroup.com](mailto:bill.conboy@IBIGroup.com)

### Civil Engineer

Mark Wharry, PE  
KPF Consulting Engineers  
111 SW 5<sup>th</sup> Avenue, Suite 2500  
Portland, OR 97204  
Phone: 503.806.3317  
E-mail: [mark.wharry@kpff.com](mailto:mark.wharry@kpff.com)

### Traffic Engineer

Scott Mansur  
DKS Associates  
117 Commercial Street NE, Suite 310  
Salem, OR 97301  
Phone: 503-391-8773  
E-mail: [smm@dksassociates.com](mailto:smm@dksassociates.com)

### Surveyor

Mike Rademacher, PLS  
Compass Engineering  
4107 SE International Way, Suite 705  
Milwaukie, OR 97222  
Phone: 503.653.9093  
E-mail: [miker@compass-engineering.com](mailto:miker@compass-engineering.com)

### Landscape Architect

Kristina Durant  
Walker Macy  
111 SW Oak Street, Suite 200  
Portland, OR 97204  
Phone: 503.228.3122  
Email: [kdurant@walkermacy.com](mailto:kdurant@walkermacy.com)

## Application Plan Sheets

Sheet Number	Description
LU1.00	Site Analysis Map and site Circulation
LU1.01	Existing Conditions
LU1.02	Site Plan
LU1.03	Grading Plan
LU1.04	Utility Plan
LU1.05	Storm Plan
LU1.06	Oxford and Park ROW Plan
LU1.07	Bittner ROW Plan
LU1.08	Slope Analysis
LU2.01	Tree Removal Plan
LU2.02	Landscape Plan
LU2.03	Landscape Planting Plan
LU3.01	Main Floor Plan
LU3.02	Second Floor Plan
LU3.03	Exterior Elevations
LU3.04	Building Sections and Sign
LU3.05	Exterior Materials
LU4.01	Light Coverage Plan
LU4.02	PGE Street Lighting Plan
IL-1	Illumination Plan

**Figure 1: Vicinity Map**

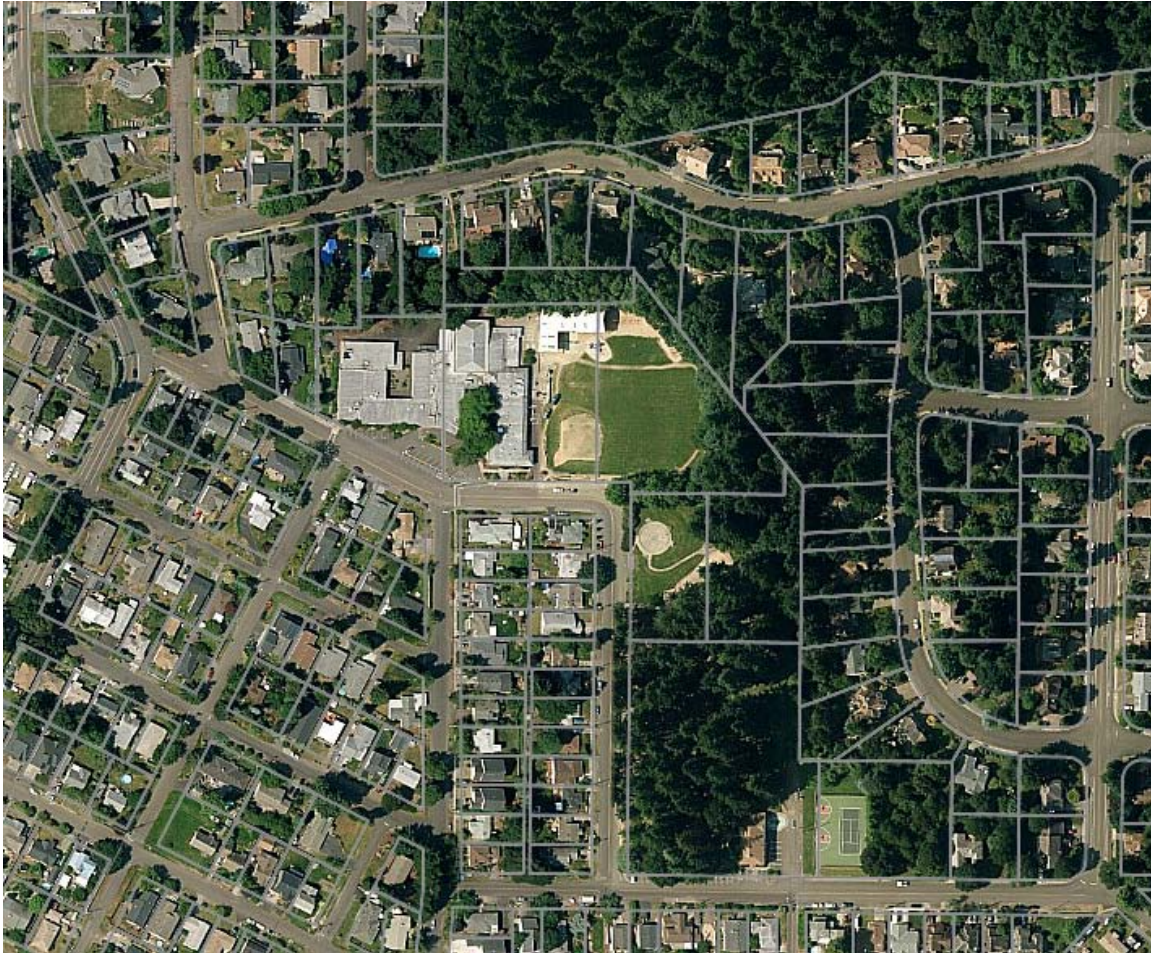

Source: Metro

## **BACKGROUND INFORMATION**

### **Site Description**

The site is developed with Sunset Primary School, one of the older facilities in the District. The property includes a 54,000 square-foot building, driveways, parking, and play areas. The entire "L"-shaped site is approximately 6.19 acres. The property was recently expanded to the southeast through the acquisition of approximately 1.6 acres from the city of West Linn. Property boundaries and easements are shown in Exhibit A. Primary access to the school is provided by Oxford Street, which runs along the south side of the school building. Bittner Street borders the west side of Sunset Park and the southeastern portion of the school property (Sheets LU1.00 and LU1.01). There are two pathway connections with Oregon City Boulevard to the north and Oregon City Loop to the east.

## Vicinity Information

The zoning designations and current land use of the surrounding area are summarized in Table 1.

**Table 1**  
**Zoning and Land Use Summary**

PARCELS	ZONE DESIGNATION	LAND USE
Subject Property	R-10	Primary school building, ancillary facilities, and parking
North/Northwest	R-10	Single family residences
East	R-10	Single family residences
South/Southwest	R-10/R-7/R-5	Single family residences and Sunset Park

## COMMUNITY ENGAGEMENT

The District provided notice, as required by the CDC, and held a meeting with the Sunset Neighborhood Association on November 10, 2015 to review the proposed design for the new school. The materials pertaining to this required meeting are provided in Exhibit B.

This meeting was the most recent in an on-going dialogue with the neighborhood about how to best replace the aging Sunset Primary School. In 2007, the school district commissioned a building evaluation of the Sunset Primary School facility by Dull Olson Weekes Architects. The October 1<sup>st</sup> report recommended replacement of the school rather than renovation of the existing facility based on anticipated cost. A task force was then assembled to review the architectural study, review the structural needs of a primary school, weigh the options of renovation and replacement, and prepare a recommendation to the Long Range Planning Committee in November 2007. Ultimately, the recommendation was to demolish the existing building and build a new facility at Oppenlander field. After considerable response from the community another task force was brought together in 2009 to develop a recommendation for locating a new Sunset Primary School. The recommendation from that task force was to reconstruct the school on the current site with additional land, a smaller school, jointly planned use of Sunset Park with City of West Linn, and to maintain usefulness of Oppenlander field for all West Linn schools.

Given this recommendation, Ballot Measure 3-358 in May 2010 asked voters to approve the sale of a portion of Sunset Park to the school district. After the sale was approved the district

and city of West Linn negotiated a land exchange in February 2011, which included use limitations on the Sunset Park property to be sold to the district. The district agreed to use its best efforts to cooperate with the City when master planning the city property and adjoining school property owned by the district, so as to maximize recreational opportunities while preserving significant trees to the extent practical while meeting the district’s requirements to replace Sunset Primary School.

Having obtained the necessary land, the school district then included the replacement of Sunset Primary School in the 2014 Ballot Measure 3-456 as part of an \$84.5 million dollar capital improvement program. The ballot measure was approved by voters in November 2014.

After a series of meetings with parents, students, teachers, and administrators to develop educational specification in the spring of 2015, the design team spent the summer drafting plans for the school and site. The school district then held a meeting with neighbors on August 20, 2015 to review the first concept plan and received a great deal of input. Various changes were made to the design in response to public comment as well as feedback from regulating bodies. The district asked the Sunset Neighborhood Association to host a meeting on October 20, 2015 to review revised plans. The October presentation included many new details as well as various compromises in response to the public comments. The Sunset Neighborhood Association graciously agreed to host another presentation on November 10<sup>th</sup> to review the latest plans before submitting the project to the city of West Linn for Land Use.

**PROPOSED IMPROVEMENTS**

The proposed Sunset Primary School site improvements include three major elements:

- Replacing the existing school building with a new primary school building.
- New on-site circulation and parking.
- New sports field and play areas.

The project will be conducted in two construction phases to allow the school to operate continuously on the site. The first phase will include construction of the new school building in the general location of the existing playground and sports field. The second phase will commence once the new school building is complete to include demolition of the existing school building and construct a new sports field in that location to replace the sports field and play areas lost during the first phase.

**Table 2  
New Primary School - Approximate Areas**

<b>LAND USE</b>	<b>AREA</b>
School District Site	6.19 acres
Primary School total building area	61,680 sq. ft.
Primary School total building footprint	42,604 sq. ft.
Existing site impervious area	2.80 acres
Proposed site impervious area	2.89 acres

## **New Primary School**

The new school building will be constructed to the east of the existing school (Sheets LU1.01 and LU1.02). It is proposed to have a 450-student architectural capacity (25 students per classroom) and 30- to 35-person staff. The architectural capacity of the existing school is 575 students. The new school will have fewer classrooms and devote more space to common instruction areas and common facilities, such as gymnasium/commons, library, and multi-purpose rooms. The September 2015 enrollment was 305 students, but it has been significantly higher in the past. The new school will have a total floor area of approximately 61,680 square feet (foot print = 42,604 SF), compared to 54,000 square feet (foot print = 43,185 SF) for the existing school.

The main building entrance and plaza will be oriented to the corner of Park Street and Bittner Street. The building will have a two-story east wing of classrooms and kitchen service, and a one-level west wing including administration, performing arts, physical education, wellness and commons area, mechanical equipment, and enclosed service yard. The maximum building height will be 40 feet (Sheet LU3.03). Open space, playground, and sports field will be located to the south, north, and west of the new school building (Sheet LU1.02).

The minimum building setbacks to the east and north are 31.7 feet and 104 feet respectively. These setbacks exceed the CDC minimums in the R-10 Zone for side yards (7.5 feet) and rear yards (20 feet). The main front building entry will have a 32.3-foot setback from the existing Park Street right-of-way line. The front entry will also feature a 15.2-foot canopy extending from the front wall a 17.1-foot setback from the right-of-way line (Sheet LU1.02). The minimum front yard setback standard for the R-10 Zone is 20 feet. An exception, as provided in CDC Section 55.170 A., is requested to allow this reduced setback.

Integrating the building with the site is an important aspect to sustainability and was a major goal of the school district. All attempts have been made to allow the building to work with the natural contours of the site and orient the teaching spaces in ways to collect the appropriate amount of daylight. This includes sizing and locating windows in a manner that provides natural daylighting for each of the learning environments; reducing the need for artificial lighting through parts of the day. The building location also facilitated the integration of sun screening devices as part of the storefront and curtain wall window systems. Along the east and west are vertical sunshades and the south facades have horizontal shading devices as part of their design. Siting the building with the large gym roof facing south also allows for a large open roof surface that could hold arrays of photovoltaic (PV) panels oriented to maximize their efficiency.

## **Circulation – On and Adjacent to the Site**

### ***Driveways***

Access will be provided by three driveways, with one each located on Oxford and Bittner streets. These driveways will be 24 feet wide to accommodate two-way traffic. They will be aligned with Sussex Street and Exeter Street. The Exeter Street driveway will also provide access for emergency and service vehicles to the rear of the new school building and to the service and trash area on the west side of the building. The alignment of the school site access

driveway opposite Exeter Street was developed specifically at the request of the city of West Linn Engineering. The third driveway, which provides required fire access from Bittner Street, will also be 24 feet wide (Sheet LU 1.02).

### ***Street Frontage Improvements***

Full street improvements are proposed for the portions of Oxford, Park, and Bittner streets that are adjacent to the school property. The District would normally be responsible for half-street frontage improvements, but the City and District will cooperatively construct full street improvements to provide improved access to the school and for the neighborhood. The improvements will include curbs, street lighting, sidewalks, and crosswalks (Sheets LU1.02, LU1.06 and LU1.07).

The sidewalk adjacent to the school site will have a minimum width of 6 feet along the street frontages to the west of the middle driveway and south of the Bittner Street driveway. The sidewalk will be 10.5 feet adjacent to the bus loading area on Park Street and 8 feet on the remainder of the Bittner Street frontage (Sheets LU1.02, LU1.06 and LU1.07). Street lights are designed to meet applicable city standards for local streets.

### ***Pedestrians and Bicyclists***

The *Sunset Primary School Transportation Analysis and Safe Routes to School Plan* developed by DKS (Exhibit C) shows that the sidewalk and bicycle facility system in the vicinity of the school site is not complete. The proposed school improvements Sheets LU1.02, LU1.06, and LU1.07 will make a significant contribution to improving the pedestrian and bicycle facilities in the vicinity by:

- Constructing full street improvements along the entire site frontage including sidewalks, and crosswalks in front of the new school building.
- Creating an on-site pathway connection between the school entrance and the existing pathway connection with Oregon City Loop.
- Enhancing the existing pathway between the property and Oregon City Boulevard by providing a more direct and safe route to the school property.

### ***Emergency Access***

Emergency access will be provided via the parking lot driveways plus a driveway and fire lane, which will be located on the west, north and south sides of the school building. These driveways will provide suitable emergency access to all portions of the property.

### ***Traffic Impacts***

The *Sunset Primary School Transportation Analysis and Safe Routes to School Plan* (Exhibit C) analyzes the potential traffic impacts associated with the proposed primary school. The primary DKS conclusions are summarized below:

- Based upon an architectural capacity of 575 students for the existing school, a total of 742 daily trips would be anticipated.
- With an architectural capacity of 450 students for the new school, a total of 581 total daily trips would be estimated, representing a decline of 161 trips (DKS report, Tables 1 and 2).

- The existing pedestrian crossings on Oxford Street at Sussex Street and Exeter Street should be removed and replaced with new crosswalks near the new middle driveway on Park (Oxford) Street and the new driveway on Bittner Street.
- The report identifies desirable sidewalk infill to be completed in the neighborhood. The District and City will be cooperating to create full street improvements on the street segments adjacent to the school. These improvements, along with the vastly improved crosswalks, will be a significant first step toward providing a more complete pedestrian network.

## **Circulation – Safe Routes to School**

In addition to making significant right-of-way improvements along the frontage, the district will create a safe routes plan for distribution prior to the opening of the school. This plan will note the locations of sidewalks and preferred walking paths to walk or bicycle to and from the school. Circulation routes are illustrated on Sheet LU1.00.

## **Parking and Loading**

During the first construction phase, the existing on-site parking will remain. Once the new school building is in place, the parking will be reconfigured and expanded to include a new 11-space lot immediately south of the east wing and a 77-space lot, including 5 handicapped spaces, on the west side of the property and along Oxford Street. This will represent a significant increase from the current 27 spaces (including 2 handicapped) to a total of 88 spaces (Sheet LU1.02).

CDC 46.090 B requires one space for each employee plus one space for every 1,000 square feet of floor area. With a maximum of 35 employees and a total of 61,680 square feet of floor area, the school is required to have 97 parking spaces. The district could provide an additional 9 parking spaces in the southern parking lot to meet the CDC requirements, but it would necessitate removing additional trees, which neighborhood representatives would like to remain. In response, the district is requesting a Director's Exception to allow 88 on-site parking spaces where 97 are normally required.

The western parking spaces will be located between approximately 180 and 560 feet from the main building entrance. The parking spaces in the southern lot are approximately 110 to 200 feet from the main building entrance. The city's standard for the maximum distance between parking spaces and the primary building entrance is 200 feet. Therefore, a variance is requested to allow parking at distances greater than 200 feet.

CDC Section 46.150 D. requires 2 bicycle parking spaces per classroom with a minimum of 50% being covered. With 18 classrooms, the total required bicycle parking is 36 spaces. Forty bicycle parking spaces are proposed in two locations. Twenty uncovered spaces will be located within 50 feet of the front entrance, and the remaining 20 spaces will be covered and located approximately 130 feet to the west of the front entrance (Sheet LU1.02). A variance to the 50-foot distance standards is requested for the 20 covered bike spaces.



One loading space is required for a school of less than 100,000 square feet. The proposed primary school will have approximately 61,680 square feet. The required loading space will be provided in a service area located in the west wing with direct access to the central access drive and fire lane (Sheets LU1.02 and 3.01).

## **Sports Field and Play Areas**

The existing school has a grass sports field, play area, and covered play area located in the northeastern portion of the property. These existing facilities are all proposed to be replaced with new play areas between the school building and the north property line, a sports field between the school and western parking lot, and a pathway loop on the east side of the building (Sheets LU1.01 and LU1.02). There is currently a small recreational area and play structures located in the southern part of the property along Bittner Street. These facilities are proposed to be removed to accommodate the required storm treatment and detention facility (Sheet LU1.02).

## **Trees**

There are 133 trees over a 6-inch diameter on the site. Of the 133 trees, 62 fir trees were considered to be significant. To accommodate the new school and related facilities, 12 significant trees and 40 other trees are proposed to be removed to accommodate the new school. In addition, 4 of the significant trees may need to be removed, but this determination will be made after construction has commenced. The remaining trees will be protected in place (LU2.01). The retention of trees near the property line will retain important visual buffering for adjacent properties.

In addition to accommodating the new building and parking lots, some of the tree removal is necessitated by a required, storm water detention/treatment area located immediately south of the southern parking lot (Sheets LU1.02 and LU1.05). Every effort has been made to minimize the extent of the tree removal and to maintain existing visual buffers for surrounding properties.

The District retained an arborist to evaluate the trees and proposed tree removal on the site (Exhibit D). The district staff and arborist met with Mike Perkins, the City of West Linn Arborist, on December 8, 2015 to review the proposed removal of trees on site. Based on the conversation during the field visit, the proposed tree protection and removal plan was considered by all to be appropriate.

## **Landscaping**

Understory brush and weeds beneath existing trees along the east property boundary will be removed and replaced with bark mulch, groundcover, shrubs, site trees, and street trees will be provided in the quantities, size and location required by the CDC (Sheets LU2.02 and LU2.03). A 6-foot galvanized chain link fence is proposed along the entire east, north, and west boundary of the site (Sheet LU2.02).

## **Potential Noise**

Potential noise issues have been studied and evaluated by the district. A memorandum of anticipate site noise conditions was prepared by BRC Acoustics and Audiovisual Design was prepared as part of this application (Exhibit E). The study evaluated three primary noise sources: 1) traffic and vehicles, 2) outdoor play areas, and 3) on-site equipment and mechanical systems. The memorandum concludes that the city's noise standards will be met.

## **Utilities**

A number of public facility improvements are proposed as part of the new school construction. Many of them will be part of the street improvements.

### ***Oxford Street Public Improvements***

Overall street improvements provided by the District and the City are proposed to include a fully improved street section including two travel lanes, curbs, planter strips in some locations, sidewalks, and several marked crosswalks. No other public utility improvements are proposed for Oxford Street (Sheet LU1.06). A public utility easement (PUE) will be placed for underground extension of power and franchise utilities.

### ***Park Street Public Improvements***

Overall half-street improvements provided by the District are to include a 16-foot wide pavement for travel lane and bike lane, 6-inch curb, 5.5-foot wide planter strip and 10-foot wide sidewalk. Bus drop-off will be configured along the sidewalk within the Park Road ROW. Just outside the right-of-way, a 5-foot wide (PUE) will be placed for underground extension of power and franchise utilities. Similar to Oxford Street, the City will provide the remaining street improvements (Sheet LU1.06).

An 8-inch water line will also be extended as part of the Park Street public improvements. Line extension size was confirmed by water modeling provided by city staff. The water line will be extended down Bittner Street as well to complete a loop connection at the intersection of Bittner and Long Streets. Because much of the water system work is intended to improve service in the general area, the city will be financing the water line between the property frontage and Long Street to the south.

### ***Bittner Street Public Improvements***

Overall half-street improvements provided by the District are to include a 16-foot wide pavement for travel lane, 6-inch curb, 5.5-foot wide planter strip and 8-foot wide sidewalk. Parent drop-off will be configured along the sidewalk within the Bittner Street right-of-way. Similar to the other streets, the City will provide the remaining street improvements. These surface street improvements are proposed for the length of the school property frontage on Bittner Street.

As described above, the new 8-inch water line will also be extended as part of the Bittner Street public improvements. The new water line will extend south to Long Street. In addition, a 12-inch public storm sewer extension will be installed the length of Bittner to provide a new storm

drainage connection from the school site to the intersection of Bittner and Long Streets to the south.

A 6-inch sanitary line will be extended across Bittner Street and will tie into an existing sanitary sewer on the west side of the street. This has been reviewed with the city's Engineering Department. The proposed Bittner Street surface and utility improvements are shown on Sheet LU1.07.

### ***On-site Storm Water Treatment and Drainage***

On-site treatment, detention and discharge from the site will be needed for treatment of storm water. Discussed with the city of West Linn, the site is very constrained for the proposed school development. After consultation with city of West Linn Engineering, storm water treatment and detention is proposed for the project with a new storm water facility pond located at the southeast corner of the site (at the location of the existing playground area). The construction of this facility will require removal of the existing playground and a number of the existing trees.

The proposed new water quality planter facility will be designed to provide the required water quality treatment and detention for the entire school site prior to discharge to the city system (new proposed storm sewer extension down Bittner described above).

Note that the site is currently developed and storm water runoff currently drains to an existing system that runs down Exeter Street to Long Street. There is no treatment or detention for the existing development. The new system will be designed to treat stormwater runoff per city requirements and to detain peak flows to pre-development levels (natural undeveloped state - not the existing condition). Consequently, stormwater discharge flows from the new school development will be significantly less than from the existing school site.

The existing public storm drain system currently serving the Sunset Primary School site is underdeveloped and a number of alternatives were evaluated to provide an adequate new storm drain connection for the proposed school development. The proposed option of extending a new public storm main down Bittner was selected for a number of reasons:

1. It was deemed the least disruptive to the neighborhood. The project is already extending a new public water main down Bittner as well, so that street will already be impacted.
2. It is the shortest route (and consequently the least costly) for a new storm sewer extension.
3. It will convey the new school runoff to a system and drainage where it currently goes.

Additional information regarding the storm water analysis is provided in Exhibit F.

## **Lighting**

On-site lighting will be provided for the driveways, parking lots, play areas, and building, but the play field will not be illuminated. The lighting is designed to only cast light onto the property and not adjoining properties. The lighting plan (Sheet LU4.01) indicates the expected light levels and how light will not escape beyond the property boundary. Lighting plans for the public

street were also obtained from PGE, demonstrating how the streets will be properly illuminated (sheets LU4.02 and IL-1).

## **Refuse and Recycling**

This area will be located in the southwestern corner of the building. There will be an enclosed area for a compactor, refuse, and recycling storage. Access will be provided by the central driveway and fire lane located on the west and north sides of the new school building. It will be partially enclosed to reduce its visibility and any potential noise impacts. The separation and storage of these materials will be consistent with the solid waste hauler and DEQ.

## **Signs**

The district proposes one raised letter building sign above the main building entrance (Sheet LU3.03). This sign is proposed to use 18-inch tall metal letters along the top of the canopy over the front entrance. With a proposed length of approximately 28 feet, the sign would be approximately 42 square feet. It is considered as a wall sign, which has a maximum size requirement of 18 square feet. A variance is requested to allow a wall sign, which is greater than 18 square feet.

A monument sign is also proposed in front of the main building entrance near the corner of Park and Bittner streets (Sheets LU2.02 and LU3.04). It would have only one side facing the street. The entire sign structure would be approximately 65 square feet with a maximum height of 6 feet and a 12-foot length. The concrete sign would include a prominent place for the historic bell and a message "Sunset Primary School, 2351 Oxford Street" totaling approximately 6 square feet. The sign would employ recessed cut out letters, and it would be illuminated by recessed exterior lighting that is flush with the sidewalk. A 13.5 square-foot, manual, backlit reader board sign is also proposed above the address sign for a total sign area of approximately 19.5 square feet.

## **Application Elements**

To gain city approval for the above improvements, the application contains four elements.

### ***Conditional Use***

Schools are categorized as conditional uses in the R-10 Zone. The applicable review criteria are found in Chapter 60 of the CDC.

### ***Design Review***

Design review is required for non-residential development. CDC Chapter 55 contains the applicable review criteria along with references to relevant criteria in other portions of the CDC, which must also be satisfied.

### ***Exceptions***

An exception to allow a 17.1-foot front yard setback where 20 is required in CDC Section 11.070.

An exception to the required number of parking spaces is requested to allow 88 on-site parking spaces where 97 spaces are required by CDC Section 46.090.

***Class II Variances***

A Class II Variance to allow on-site parking spaces to be located beyond the 200-foot maximum distance as required in CDC Section 46.070.

A Class II Variance to allow on-site bike parking spaces to be located beyond the 50-foot maximum distance to the building entrance as required in CDC Section 46.150.

A Class II Variance to allow a wall sign of approximately 28 square feet where a maximum of 18 feet is required in CDC Section 52.300.

**APPLICABLE CRITERIA - CONDITIONAL USE REVIEW**

The relevant review criteria in the CDC include the Single Family Residential Detached, R-10 requirements (Chapter 11), Conditional Use evaluation criteria (Chapter 60), Comprehensive Plan policies, Design Review (Chapter 55), and Variance (Chapter 75). These criteria are addressed below.

***Chapter 11 Single Family Residential Detached, R-10***

**Section 11.060 Conditional Uses**

Schools are listed as a conditional use in the R-10 zone. The entire property is located within the R-10 Zone, and therefore, the proposed new primary school is eligible to receive conditional use approval.

**Section 11.070 Dimensional Requirements**

With the exception of the front yard setback of 17.1 feet where 20 feet is required, the proposed school building exceeds all of the minimum setback standards. The normal maximum height in the R-10 Zone is 35 feet, however, CDC Section 41.040 allows school to have a maximum height of 50 feet, subject to criteria, which are addressed below.

**Section 11.080 Dimensional Requirements, Conditional Uses**

This section gives the Planning Commission the authority to determine the appropriate parcel size and dimensions for a conditional use.

The school site historically was smaller than it is today. It has operated effectively and in a manner compatible with the surrounding neighborhood for decades. Following the District's acquisition of a portion of a property owned by the city to the southeast, the total property size is now 6.19 acres. This additional land area will allow the school to enhance its operation and benefit the neighborhood.

This property has proven to be suitable for a primary school, and the neighborhood has

expressed its support for retaining a primary school on the site. The new school building will not be significantly larger than the existing school, and the actual enrollment capacity of the building will decrease due to more space being programmed for common facilities. The additional site area will also enable the district to provide significantly more on-site parking. Finally, the proposed street and pathway improvements will provide greatly enhanced multi-modal access to and from the school, which will be less disruptive to the surrounding neighborhood.

**Section 11.090 Other Applicable Development Standards**

This section lists the other CDC Chapters that apply or potentially apply to all development in the R-10 Zone. The applicable CDC chapters are addressed later in this narrative under Design Review.

***Chapter 60 Conditional Uses***

**Section 60.070 Approval Standards and Conditions**

This code section states that the applicant must provide evidence substantiating that the proposed use satisfies seven criteria, which are addressed below:

**A. The following criteria shall be satisfied.**

**1. The site size and dimensions provide:**

**a. Adequate area for the needs of the proposed use.**

The school has been in continuous use for many years, and this site has proven to be suitable for the primary school, its operation, and for maintaining a compatible relationship with the surrounding neighborhood. As mentioned above, the new primary school will have the advantage of a larger site as a result of the 1.6-acre expansion. The new primary school will function similarly to the existing school by maintaining an enrollment comparable to the existing school.

**b. Adequate area for aesthetic design treatment to mitigate any possible adverse effect from the use on surrounding properties and uses.**

As shown on the site plan information, the setback distances for buildings, parking, play areas, and related facilities from all property lines will continue to be substantial. The new school will address several problems related to the existing school including:

- More than tripling the deficient on-site parking.
- Improving the safety and convenience of access to the site for all modes.
- Improved bus loading and parent drop-off areas.
- Maintaining the majority of the trees on the site.
- Providing improved landscaping that meets city standards.

**2. *The characteristics of the site are suitable for the proposed use considering size, shape, location, topography and natural features.***

The existing primary school site has proven to be suitable for the district and the community. The approval of the new bond measure to provide the funding for the new school demonstrates continued community support for the proposed reconstruction of the school. Although the site is smaller than many of the existing primary school sites in the district, the school has demonstrated it can operate in a manner that is compatible with the surrounding neighborhood. Because the capacity of the school will be slightly reduced, the proposed improvements will not pose any new potential impacts for the surrounding neighborhood.

**3. *The granting of the proposal will provide for a facility that is consistent with the overall needs of the community.***

The needs of the community are best expressed by its approval of the bond measure to finance these improvements. In addition, the Sunset Neighborhood Association held a meeting on November 10, 2015 to review and comment on the proposed school. Questions regarding specific aspects of the facility design were asked, but no significant concerns were raised. The association did not take a formal vote on the proposal. The relevant city policies are addressed under criterion 7 below.

**4. *Adequate public facilities will be available to provide service to the property at the time of occupancy.***

Transportation

As noted in the project description, significant street, sidewalk, and pathway improvements will be made as part of the project. These improvements will vastly improve the safety and convenience for all transportation modes.

Water

Water service is presently adequate, and because no additional demands will be placed on the system, it will adequately continue to serve the school.

Sanitary and Storm Sewer

Sanitary and storm sewer service is currently satisfactory. In coordination with the city, facilities will be upgraded to comply with current standards. In particular, storm drainage will now receive more thorough treatment and detention.

**5. *The applicable requirements of the zone are met except as modified by this (Conditional Use) chapter.***

The applicable CDC requirements for building setbacks and lot coverage will continue to be satisfied as explained above.

The appropriate lot size is confirmed as part of the conditional use review. Because the use is proposed to remain essentially as it is today, the expanded 6.19-acre site continues to be appropriate for a primary school.

Two exceptions and three variances are requested as part of this application. As noted later in this narrative, they all satisfy the applicable approval criteria.

**6. *The supplementary requirements set forth in Chapters 52 to 55 CDC, if applicable, are met.***

Chapter 52 - Signs

One wall sign and one freestanding sign are requested as part of this application. The applicable approval criteria are addressed later in this narrative.

Chapter 55 – Design Review

CDC Section 55.100 A. includes a list of CDC chapters, which must be satisfied as part of Design Review. The applicable approval criteria are addressed later in this narrative.

**7. *The use will comply with the applicable policies of the Comprehensive Plan.***

The relevant city policies for schools are found in the West Linn Comprehensive Plan. The relevant policies are addressed below.

*Policy 4 (Section 1: Air Quality – GOAL 6: Air, Water, and Land Resources Quality)*

*Encourage the use of alternative modes of transportation, including mass transit, walking, and bicycling.*

In the design of the school, the supporting transportation infrastructure, and pathway improvements will facilitate safe and convenient multi-modal access.

*Policy 1 (Section 2: Water Quality – GOAL 6: Air, Water, and Land Resources Quality)*

*Require that new development be designed and constructed to prevent degradation of surface and ground water quality by runoff.*

Appropriate erosion control and water quality measures will be taken to comply with this policy and related regulations. These measures will be reviewed by the city as part of the building permit process.

*Policy 4 (Water Quality)*

*Require that new development be connected to the City's sanitary sewer system.*



The school will continue to be connected to sanitary sewer.

*Policy 2 (Section 4: Noise Control)*

*Require development proposals that are expected to generate noise to incorporate landscaping and other techniques to reduce noise impacts to levels compatible with surrounding land uses.*

*Policy 3 (Section 4: Noise Control)*

*Require new commercial, industrial, and public facilities to be designed and landscaped to meet Department of Environmental Quality (DEQ) and City noise standards.*

*Policy 4 (Section 4: Noise Control)*

*As part of the land use application submittal for a noise-generating use, require the applicant to include a statement from a licensed acoustical engineer, and, if necessary, from DEQ, declaring that all applicable standards can be met.*

Noise policies 2, 3, and 4 above will be satisfied because the proposed improvements will not appreciably change use patterns on the site or increase associated noise. Most important, the building function, orientation, and capacity will remain essentially as it is today. The noise analysis, provided in Exhibit C, shows that all applicable noise standards can be met.

*Policy 3 (Section 3: Storm Drainage - GOAL 11: Public Facilities and Services)*

*Protect downstream areas from increased storm water runoff by managing runoff from upstream development and impacts on adjacent natural drainageways and their associated vegetation.*

The proposed site work has been designed to meet this policy. The proposed site work will not have any appreciable impact on storm water runoff because the amount of impervious surface will remain virtually the same as it is today. In addition, a new storm water treatment and detention facility is proposed in the southern portion of the site.

*Policy 1: (Section 7: Schools - GOAL 11: Public Facilities and Services)*

*Encourage the School District to build schools on collectors or arterial streets and, where possible, along transit lines.*

As noted in this application, the school has been in this location for a long time, and it is well-integrated with the neighborhood. Access to the school has been provided without undue impacts on the neighborhood. The multi-modal access improvements coupled with slight decrease in the potential enrollment will enhance accessibility and compatibility with the surrounding neighborhood.

*Policy 2: (Section 7: Schools - GOAL 11: Public Facilities and Services)*

*Encourage the use of energy-responsive materials and processes in the design of schools where economically feasible.*

As noted in the project description, the school will employ energy-saving design features. In addition, the school will be required to meet current building and energy codes, which will result in vastly superior energy and resource conservation compared to the existing building.

*Policy 4: (Section 7: Schools - GOAL 11: Public Facilities and Services)*

*School design, use, and parking will be responsive to and compatible with surrounding neighborhoods and existing land uses.*

As noted in this application, the school has been in this location for a long time, and it is well-integrated with the neighborhood. The proposed school will further enhance its relationship with the neighborhood by having a slightly reduced enrollment capacity, greatly improved street and multi-modal accessibility, significantly more on-site parking, and an improved building design.

*Policy 4: Bicycles (GOAL 12: Transportation)*

*Require new commercial, industrial, and institutional development to provide on-site facilities for bicycle parking and storage.*

The proposed bicycle parking spaces will continue to provide improved parking convenience for cyclists, including a combination of covered and uncovered spaces near the front entrance.

*Policy 1b: Pedestrians (GOAL 12: Transportation)*

*Provide connections to schools, recreation facilities, community centers, and transit facilities.*

The public street and on-site walkway system will be enhanced significantly, including new sidewalks, crosswalks, and pathway improvements.

*Policy 1c: Pedestrians (GOAL 12: Transportation)*

*Use off-street pedestrian "short-cut" pathways to provide routes where physical constraints or existing development preclude the construction of streets with sidewalks.*

The school site will continue to take advantage of the two existing pathway connections with Oregon City Boulevard to the north and Oregon City Loop to the east. The northern pathway will be improved to create a straight, more visible, and safer route in and out of the site. Connection between the eastern pathway and the school entrance will also be provided.

*Policy 1e: Pedestrians (GOAL 12: Transportation)*

*Eliminate gaps in the existing walkway network and provide pedestrian linkages between neighborhoods.*

The existing school does not have full half-street improvements including sidewalk. In partnership with the City, the District will provide full street improvements for the portions of Oxford, Park, and Bittner streets, which abut the school property. This will include sidewalk on both sides of the street and new, clearly delineated crosswalks. These improvements, along with the pathways noted above, will greatly improve the safety and convenience of walking or bicycling to school.

*Policy 2: Pedestrians (GOAL 12: Transportation)*

*Employ a variety of methods to promote safe and convenient pedestrian access in addition to, or instead of, sidewalks in older developed areas of West Linn without sidewalks.*

The school site will continue to take advantage of the two existing pathway connections with Oregon City Boulevard to the north and Oregon City Loop to the east. The northern pathway will be improved to create a straight, more visible, and safer route in and out of the site. A better connection between the eastern pathway and the school entrance will also be provided.

*Policy 6: (GOAL 13: Energy Conservation)*

*Encourage the use of energy-conscious design and materials in all public facilities.*

As noted in the project description, the building design incorporates methods to reduce energy demand for lighting, heating, and cooling. It also features a roof design that can accommodate solar energy equipment.

*Policy 7: (GOAL 13: Energy Conservation)*

*Encourage the construction and maintenance of sidewalks and bike paths/ways to promote alternative modes of transportation.*

As noted above, the new school will include improvements to the existing pathway connections in addition to the full street improvements to Oxford, Park, and Bittner streets.

**B. Development review provisions in Chapter 55 shall be satisfied.**

These criteria are addressed below.

**C. The Planning Commission may impose conditions.**

The District understands that the Planning Commission has the authority to impose conditions.

**D. Aggregate extraction uses.**

This subsection is not relevant because aggregate extraction is not proposed.

**E. Historic review.**

This subsection is not relevant because the school is not a designated historic resource.

**Section 60.100 Additional Criteria for Schools and other Government Facilities**

*This code section states that schools and other government facilities, which will attract a regular and significant volume of users should be centrally located relative to the population to be served.*

The Sunset Primary School has been serving the central West Linn neighborhoods for decades, and the community has expressed a desire to replace, not move, the school so the new school may continue to serve this area of the city. It is centrally located within its attendance area.

**APPLICABLE CRITERIA - DESIGN REVIEW**

At the conclusion of the pre-application conference, the planning staff determined that a Class II Design Review application would be necessary. The application must meet criteria in CDC Chapter 55 as identified and responded to below:

**CDC 55.100 Approval Standards – Class II Design Review**

**A. The provisions of the following chapters shall be met:**

**1. Chapter 34 – Accessory Structures, Dwelling Units, and Uses**

This chapter is not applicable because no accessory structures or uses are proposed.

**2. Chapter 38 – Additional Yard Area**

Section 38.030 requires minimum setbacks from street centerlines of 25 feet plus the required yard setback. The design of Oxford, Park, and Bittner streets have been developed in coordination with the city staff and the proposed building will provide the setbacks required in this section. The City Engineer expressed the desire to improve the street according to the TSP revisions that are anticipated for adoption this year. Sheet LU1.02 demonstrates how the school building will provide the required 25 feet from the centerline plus the required 20-foot front yard setback except for the small portion of the front façade that is the subject of the Director’s Exception for a 17.1-foot setback.

**3. Chapter 41 – Building Height, Structures on Steep Lots, Exceptions**

Section 41.040 states that a school may be a maximum of 50 feet in height subject to meeting three approval criteria, which are met by the school design featuring a maximum height of 40 feet because:

- A. The total floor area represents less than 25% of the 6.19-acre site area based upon the following calculation: 61,680 sq. ft. (total floor area) ÷ 269,636 sq. ft. (total site area) = 22.9%. This is well under the maximum floor area of 1.5 times greater than the site area.
- B. This section requires minimum setbacks, which are greater than or equal to two-thirds of the building height. Because the building height varies for different portions of the building, the required minimum setback also varies accordingly. The maximum building height at the exterior walls is generally 33 feet. Portions of the east wing of the building reach approximately 41 feet. Table 3 below summarizes how this minimum setback standard is satisfied for all yard areas.

**Table 3  
Demonstration of Setback Compliance**

<b>SETBACK</b>	<b>BUILDING HEIGHT</b>	<b>BUILDING SETBACK</b>	<b>REQUIRED SETBACK</b>
Front (entrance)	12.3 ft.	17.1 ft.	8.1 ft.*
Front (east)	41 ft.	42 ft.	27 ft.
Side (east)	41 ft.	33 ft.	27 ft.
Side (west)	33 ft.	380 ft.	22 ft.
Rear (north)	33 ft.	104 ft.	22 ft.

\* It is assumed the normal 20' setback still applies.

- C. This request for additional building height is included as part of a conditional use application.

**4. Chapter 42 – Clear Vision Areas**

Section 42.040 requires that a 30-foot triangular area be kept clear of obstructions and vegetation, which would inhibit visibility for motorists and other street users. These clear vision requirements adjacent to street intersections and driveways will be provided as indicated in site and landscaping plans.

**5. Chapter 44 – Fences**

Section 44.020 contains the requirements for fence heights in front, side, and rear yards. The proposed 6-foot high chain link fencing on the boundaries of the site satisfy the requirements of this CDC chapter.

## **6. Chapter 46 – Off-Street Parking and Loading**

Section 46.070 B. requires parking spaces to be within 200 feet of main building entrances, and as indicated, some of the required parking spaces are farther from main building entrances up to 560 feet. Therefore, a variance is requested. The variance criteria are addressed later in this application narrative.

Section 46.090 requires 1 vehicle parking space for every employee, plus 1 space for every 1,000 square feet of floor area. With a maximum of 35 staff and a total of 61,680 square feet, a total of 97 spaces is required based upon the following calculation: 35 spaces (1 per employee) + 62 spaces (1 per 1,000 sq. ft. of floor area) = 97 spaces. The district is proposing to provide 88 spaces. Section 55.170 allows for parking exceptions for reductions of no more than 10%. The exception criteria are addressed later in this application narrative.

Section 46.120 requires a driveway to accommodate forward traffic flow for the purpose of loading/unloading passengers. This function is accommodated with a parent/student loading area along the Bittner Street frontage as illustrated on the site plan and the circulation plan (sheets LU1.00 and LU1.02).

Section 46.130 requires one loading berth for the school, which is provided on the west side of the building.

Section 46.150 contains design standards for parking lots, and the proposed site plan complies with these standards. Section 46.150 A. contains a number of standards for parking, loading, and access, which are all satisfied:

1. A minimum of the required parking spaces must be standard (9' X 18'), and the remainder may be compact (8' X 16'). The site plan (Sheet LU1.02) identifies 14 compact spaces in the center of the western parking lot. This is well within the 50% maximum for compact spaces.
2. Disabled parking must be located as close as possible to building entries, and this has been satisfied as shown in the site plan.
3. Repealed.
4. The one service drive is located in a way to minimize potential conflict with other vehicular traffic and pedestrians.
5. The loading area is not near any parking spaces, and therefore conflicts with parked vehicles will not occur.
6. As indicated, the parking, loading, and driveway surfaces will be paved and appropriately marked as required by the city.
7. Not relevant because no park or trailhead parking is proposed.
8. Not relevant because it relates only to residential development.
9. The access drives have been limited to three, and they are found to be appropriate in the DKS report and the City Engineer.
10. The driveways will meet vision clearance requirements as noted under CDC 42 Clear Vision Areas, which is contained in this narrative.
11. Perimeter parking spaces shall include wheel stops.
12. The utility plans indicate how surface storm water will be collected and treated on the

- site in a manner consistent with City Engineer requirements.
13. The parking areas shall be illuminated in a manner that will not adversely affect adjoining properties, as shown on Sheet LU4.01.
  14. Directional and traffic control devices shall be provided as recommended in the traffic study and the City Engineer.
  15. All parking lot and driveway grades are significantly less than 15%.
  16. Not relevant because no visitor or guest parking is proposed.
  17. The parking lots are all less than a 5% maximum allowable grade as shown in the plans.
  18. None of the parking spaces are located in front of the building.
  19. Paved parking spaces are provided in groups of 12 or less.
  20. Pedestrian walkways will be provided, as shown in the plans to link parking lots and primary building entrances and activity areas on the site. Street and driveway crossings will be identified with paint markings.
  21. The parking lot layouts are very basic and will allow safe circulation for vehicles, emergency vehicles, pedestrians, and bicyclists.
  22. The on-site parking spaces have been located as close as possible to the building entrances. However, due to the size and configuration of the site, some spaces will exceed the standards in 46.070, and a variance is requested.
  23. Not applicable because the parking spaces will not have a permeable surface.

Section 46.150 B. requires 4 accessible parking spaces (including 1 van space) for the school. Five accessible spaces are proposed near the front building entrance, will be ADA design requirements, and will have access aisles as specified in this section.

Section 46.150 C. refers to the landscaping standards in CDC 54 Landscaping, which are addressed herein.

Section 46.150 D. requires two bike parking spaces per classroom with the parking located within 50 feet of the building entrance and a minimum of 50% of the spaces covered. The proposed bike parking will include 20 uncovered spaces within 50 feet of the building entrance and another 20 covered spaces within 130 feet of the front entrance. A variance is requested to exceed the distance standard for the 20 covered spaces. The variance criteria are addressed later in this narrative.

Section 46.150 E. only applies to office and industrial development.

Section 46.150 F. contains the parking lot design standards, which are satisfied as demonstrated in the plan sheets.

## **7. Chapter 48 – Access, Egress and Circulation**

Section 48.025 B. contains several requirements pertaining to access controls, which are satisfied:

1. A traffic impact analysis is provided with this application.
2. Working with the City Engineer, the proposed new school will consolidate and organize access to the city street in a manner that will greatly enhance safety and convenience for all travel modes.

3. Of the access options allowed in this section, the school will continue to obtain access directly from city streets.
4. Not applicable because a subdivision is not proposed.
5. Not applicable because no double frontage lots are involved.
6. Access spacing is designed to satisfy TSP requirements, and this has been confirmed in the traffic study.
7. The number of driveways has been minimized and located in coordination with city staff and the recommendations in the traffic study.
8. This section encourages providing driveway access to adjoining properties. In this case, all adjoining properties are developed with access from other streets, making this inapplicable to this application.

Section 48.025 C. includes standards relating to connectivity and formation of blocks. Subsection 1. is not applicable, because the property does not have frontage on an arterial. Subsection 2. will be satisfied because the property street frontage is designed to be rebuilt to current city standards. Subsection 3 allows exceptions, but in working with the City Engineer regarding the design of public improvements, the need for any exceptions has not been identified.

Section 48.040 requires driveway widths of 24 feet for 2-way and 15 feet for 1-way traffic. The proposed driveways and on-site circulation will satisfy the standards in this section, which require minimum driveway widths, adequate maneuvering space on-site, average gradients of less than 10 percent, and parking spaces and service areas that will not require backing into a public street.

Section 48.060 regulates curb cut location and widths, the proposed driveway locations, spacing and widths meet these standards as illustrated on the plan sheets. Vision at driveway intersections will be provided with locations recommended in the traffic study. In addition, the landscaping plan does not feature any plantings that would interfere with vision clearance.

## **8. Chapter 52 – Signs**

Section 52.210 contains several approval standards that must be met. The wall sign and freestanding sign proposed for the Sunset Primary School meet the sign permit approval standards as noted below:

- A. The scale of the signs and their components is appropriate for their location near the main building entrance. At 6 feet tall with an approximate 19.5 square-foot message for the school name, address, and reader board, the freestanding sign is well within the maximum size requirement of 24 square feet in CDC 52.300. The lighting and materials will be very low-key and in keeping with the surrounding residential neighborhood.

At approximately 15 feet in height with 18-inch metal letters, the proposed wall sign on the front entrance canopy satisfies all of the code standards except for the maximum area standard of 18 square feet. A variance is requested to exceed this standard.



- B. The signs are consistent with this standard because the freestanding sign will be illuminated by lights directed at the sign and a backlit reader board, and the light will not shine directly to any off-site location. The proposed wall sign will not be illuminated.
- C. The signs will not be within a clear vision area as demonstrated in the plan sheets.
- D. This criterion is not applicable because the signs will not be located over or adjacent to vehicle driveways or roadways.
- E. This criterion is satisfied because the freestanding lighting will be shielded from any off-site vantage point, and the wall sign will not be illuminated.
- F. The signs will not cause the removal of any trees or affect any natural features on the site.
- G. This criterion is met because the signs will be located within a landscaped area, and the concrete construction will be able to withstand weather and insects.
- H. This standard is not applicable because changeable copy is not proposed.
- I. This standard is not applicable because changeable electronic copy is not proposed.
- J. This criterion is not applicable because the signs shall only be visible from one side.

*52.300 Permanent Sign Design Standards*

Section 52.300 contains design standards for permanent signs. The proposed freestanding sign is significantly smaller than the allowed maximum 20-foot height and 24 square-foot sign area. As indicated above, the wall sign requires a variance because it exceeds the maximum sign area of 18 square feet.

**9. Chapter 54 - Landscaping**

Section 54.020 contains several approval standards that must be met. The proposed landscaping satisfies the approval standards as noted below:

- A. The majority of the existing trees on the site will be preserved. As demonstrated in Sheet LU2.01 Tree Removal Plan and LU2.02 Landscape Plan, the retained trees will be incorporated into the landscaping theme for the entire site. The tree removal and protection plans were reviewed in the field by a consulting arborist and the City Arborist, and they both found the plan shown on LU2.01 to be appropriate.
- B. The parking area is proposed to be reduced by 9 spaces to help minimize the number of trees to be removed. Providing 88 spaces in lieu of the required 97 spaces represents a 9% reduction, which is within the 10% reduction allowed in this section.
- C. The District has complied with the municipal code requirements for tree protection. As noted above the tree protection was reviewed by the City Arborist.

- D. This criterion is not applicable because there are no heritage trees on the site.
- E. Subsection 2. requires a minimum landscaped area of 20%. This is exceeded with 33% landscaped area. The remaining dimensional and design requirements for landscaped areas are satisfied as illustrated in the landscaping plans. Subsection 3. Criteria are satisfied:
- a. Defined landscape areas are evenly distributed throughout the parking areas and along the street frontage. As noted in the landscaping plans, shade trees are well-distributed at a ratio of more than the required 1 tree per 8 parking spaces. The western parking lot is over 20 spaces and it meets the minimum 10% interior landscaping standard by providing internal landscaped island of 14% of the parking lot area. The eastern parking lot is between 10 and 20 spaces and it meets the minimum 5% interior landscaping standard by providing internal landscaped islands of 11% of the parking lot area.
  - b. All of the landscaped areas have dimensions that are greater than or equal to the minimum 5-foot dimension requirement.
  - c. As shown in the plans, a significant percentage of the eastern portion of the site will be retained in its current condition, and very little soil improvement or supplemental irrigation will be needed. For the remainder of the site, which will be redeveloped and re-landscaped, appropriate soil amendment and irrigation will be provided.
  - d. The requirement for a landscaped strip of at least 10 feet between parking and loading areas and the street is satisfied with landscaped areas with dimensions in excess of 10 feet. In addition, appropriate street tree species are proposed with spacing of less than the 50-foot maximum, and other ground cover and shrubs are proposed.
  - e. Not applicable because it applies to properties with a main street or arterial street frontage.
  - f. A landscaped buffer of 5 feet is required along adjoining properties, and a minimum of 10-foot landscaped buffers is provided.
  - g. All areas in the parking lots not used for parking and maneuvering are proposed to be landscaped.
  - h. Vision clearance will be provided at all driveways and crosswalks because only low shrubs, groundcover, and lawn are proposed adjacent to these areas.
  - i. The loading and service area will be buffered by the building and the trees proposed along the site frontage.
  - j. Overall security is of the utmost importance to the district. The landscaping plan will not create any "hidden" areas or security issues for students, staff, and visitors.

- k. This district will install appropriate irrigation facilities to properly maintain the vegetation specified in the landscape plans.
  - l. The criteria in this subsection are met because many existing trees on the site will be protected. In addition, the landscape plan was prepared by an experienced landscape architecture firm, which has specified trees that will not cause the potential problems noted in this subsection.
- F. This subsection is not applicable because it applies to subdivisions.
- G. This criterion is not applicable because there are no water resource areas on the site.

**B. Relationship to the Natural and Physical Environment**

Section 55.100 B. 1. and 2. are not relevant because there are no heritage trees on the site. The location of Type I and II land is shown on Sheet LU1.08 and the tree removal and protection information is shown on Sheet LU2.01, including calculations regarding trees to be retained or removed. The significant trees in these areas are to be protected using the drip line standard in this section. With the majority of the significant trees on the site being protected, the 20% protection standard (and ability to provide the easement or dedication protection) will be satisfied. The impact of removing the trees noted in this application will be mitigated by the new landscaping proposed.

Section 55.100 B. 3. is satisfied because the existing grade, drainage pattern, and the amount of landscaped area will remain consistent with the overall grade and drainage patterns of the existing site.

Section 55.100 B. 4. is satisfied because the property generally features very gentle terrain and is geologically stable. It is not identified on the city's hazard map.

Section 55.100 B. 5. is satisfied because the school building will provide setbacks, which exceed minimum standards, with the exception of a canopy over the front entry area. As noted in the plans, the trash and recycling area is partially enclosed with significant setbacks from any neighboring residences.

Section 55.100 B. 6. is satisfied because the school building and development of the site will meet the applicable criteria:

- a. This criterion, pertaining to architecture, is satisfied because the new building will be of similar scale to the existing school. The site arrangement will utilize the existing trees, along with significant building setbacks, will buffer the tallest portions of the building from adjoining properties. The contemporary design offers a pleasing design with a variety of quality building materials and façade treatments.
- b. The proposed design provides an appropriate transition with adjacent residences by providing a combination of substantial setbacks, retention of many of the existing trees, and a landscaping plan that features substantial buffering and quality materials throughout the site.

- c. The proposed design of the school naturally will be a contrast to surrounding residences. Compatibility with the neighborhood will be accomplished by providing a superior design to the existing school, a more distinct and welcoming entrance, quality exterior finish materials, and landscaping that will provide superior buffering to what is present on the site today.
- d. The proposed school will create a much more human scale environment by providing significantly improved pedestrian facilities, a much more visible and welcoming entrance, and public spaces surrounding the building – particularly along the street frontage.
- e. Main front level transparency applies to commercial and office buildings and is not directly relevant to the school. However, the school design and its orientation to the street are consistent with these standards.
- f. The criterion calls for roofline variations and avoiding continuous flat elevations over 100 feet. As demonstrated in the building plans, the school building design easily complies with the standards along with providing pleasing visual interest and design excellence.
- g. This criterion is satisfied because the main building entrance is oriented toward the sun while including an extensive canopy to provide protection from the elements.
- h. As is evident in this application, significant improvements are proposed to provide a safe and attractive pedestrian environment, including new sidewalks, crosswalks, improved pathways, and pedestrian amenities such as public spaces, landscaping, and street trees.
- i. This criterion deals with commercial uses and pedestrian amenities in commercial districts, and it is not relevant to the school.

Section 55.100 B. 7. regarding Transportation Planning Rule compliance is satisfied because the school building and development of the site will meet the applicable criteria:

- a. This criterion relating to street orientation applies to commercial and office development and is not relevant.
- b. This criterion relating to parking lot location applies to multi-family development and is not relevant.
- c. This criterion relating to building location applies to commercial, office, and multi-family development and is not relevant.
- d. This criterion requires accessways, parking lots, and internal driveways to accommodate pedestrian circulation. The proposed site plan includes clearly delineated pedestrian routes, which are direct and separate from vehicular traffic. In

addition, the number of potential conflict points is minimized to the extent possible.

- e. The two existing pathways to the school will both be improved to provide greater utility, convenience and safety.
- f. This criterion requires at least one main building entrance on the main street. This is satisfied because the building will have a prominent front building entrance, which will be located near, and oriented to, the street.
- g. This criterion calls for providing good pedestrian access between a transit stop and the main entrance. The school buses represent a form of transit and the proposed bus loading area along the street frontage will provide excellent access to and from the main building entrance without any potential vehicle/pedestrian conflicts.
- h. This criterion requires portions of building projects to be oriented towards the main street. As described in this application, the main building entrance is directly oriented to the street. Access driveways and parking are located to the side, allowing an exceptionally welcoming building entrance and relationship to the public realm.
- i. This criterion applies to public utilities and infrastructure and is not relevant to the school.
- j. This criterion applies to trailhead parking and is not relevant to the school.

**C. Compatibility between Adjoining Uses, Buffering, and Screening**

This section calls for buffering and screening to minimize potential visual and noise impacts affecting adjoining uses. The proposed building architecture and site design provide the necessary buffering in the following ways:

- The potential noise sources identified in the noise evaluation (Exhibit E) will be installed and/or buffered to meet applicable noise standards.
- On-site parking will be landscaped and screened in accordance with CDC standards.
- Existing trees will be protected and new landscaping will be installed to provide desirable buffering for surrounding residences.
- All rooftop equipment will be screened as shown in the architectural plans.

**D. Privacy and Noise**

School activities and associated noise will continue to be compatible with the surrounding neighborhood. Building entrances and vehicle circulation will continue the current orientation to Oxford, Park, and Bittner streets. The trash and recycling area will be located within an enclosed space to minimize noise and visual impacts. Other noise-generating sources will be able to satisfy applicable noise requirements. The proposed lighting plan for the parking lots and public spaces surrounding the school will be designed to not shed light on surrounding properties. In addition, the sports field will not have lights.

**E. Private Outdoor Area**

This section only applies to multi-family development and is not relevant.

**F. Shared Outdoor Recreation Area**

This section only applies to multi-family development and is not relevant.

**G. Demarcation of Public, Semi-Public and Private Spaces**

The operation, main school entry, and playground layout will emphasize safety and surveillance, and their boundaries will continue to be clearly delineated. All exterior spaces will be visible from multiple directions inside and outside of the building.

**H. Public Transit**

This section only applies to development on a public transit route and is not relevant.

**I. Public Facilities**

Suitable public facilities shall be provided in conjunction with the new school including:

- Streets will be improved to meet city standards and comply with the recommendations in the DKS transportation analysis (Exhibit B).
- Municipal water and sanitary sewer are currently available to the site, and they will be upgraded as necessary.
- Solid waste and recycling storage will be provided with sufficient area and accessibility to accommodate service providers.

**J. Crime Prevention and Safety/Defensible Space**

The operation, main school entry, building windows, exterior lighting, and playground layout will emphasize safety and surveillance, and the boundaries of public spaces will be clearly delineated. All exterior spaces will be visible from multiple directions inside and outside of the building.

**K. Provisions for Persons with Disabilities**

Provisions for persons with disabilities will be greatly improved compared to the current situation. Full street improvements and crosswalks, ADA parking near the front entrance, and the entire building design will be in full compliance with today's standards.

**L. Signs**

This section is satisfied because the two signs will be consistent with the overall building architecture. The freestanding sign will include the old school bell to convey a sense of history related to the school site and neighborhood identity. The graphics and lettering will

be simple, tasteful, and only large enough to be legible from the street. Traffic control markings and signs will be installed as desired by the city.

**M. Utilities**

As noted in this application, the necessary utility facilities will be provided to serve the new school.

**N. Wireless Communication Facilities**

This section only applies to these types of facilities and is not relevant.

**O. Refuse and Recycling Standards**

As described in this application:

1. The proposed service yard will provide adequate spaces for recycling equipment and receptacles.
2. The service area is designed to adequately handle recycling and solid waste on a level concrete surface and in a manner acceptable to the fire marshal and waste collection company.
3. Recycling and solid waste will be handled in the services yard.
4. Special waste is not anticipated.
5. The service yard is completely screened from surrounding properties as shown on the plans.
6. Litter receptacles are not proposed in the public right-of-way.

**APPLICABLE CRITERIA - EXCEPTION**

Director's Exception approvals are sought for the following:

- Approval per CDC Section 55.170 A. to allow a 17.1-foot front yard setback where 20 feet is required in CDC Section 11.070.
- Approval per CDC Section 55.170 B. to allow 88 parking spaces where 97 spaces are required.

***Front Yard Setback Exception***

The exception criteria in Section 55.170 A. are satisfied based upon the following:

1. The front yard setback is not is not greater than 20%. The requested setback reduction from 20 to 17.1 feet is less than a 15% reduction.
2. At 6.19 acres, available space on this school site is limited. The reduction allows for a more efficient use of the site because the play and buffer areas on the rear of the building can be slightly larger.
3. The exception will allow for greater buffering for neighboring properties. In addition, because of the 90 degree bend in the street at the building entrance, the effective front setback is consistent with the normal 20-foot setback. The properties on the opposite

side of the street will not experience any visual encroachment from the minor reduction in the front yard setback.

4. As demonstrated in the site plan, the front entrance orientation and distance to the street will actually enhance pedestrian access by establishing a direct route to the front entry and eliminating any potential vehicle-pedestrian conflicts in this area.

### ***Off-Street Parking Exception***

The exception criteria in Section 55.170 B. are satisfied based upon the following:

1. The reduction of required parking spaces is not is not greater than 10%. The requested parking reduction from 97 to 88 spaces is approximately a 9% reduction.
2. The school is a permanent use, which does not have a high daily demand with 35 staff and a student body that does not drive. Parking demand for special school events will always exceed on-site parking available at virtually any school. The parking represents a significant increase compared to the current situation.
3. The opportunity for shared parking is not applicable in this case.
4. Public transportation, in the form of school buses, is available to the site. In addition, substantial improvements will be made to further encourage walking and bicycling to school. Finally, the required parking could be provided in the southeastern portion of the site, but it would require removal of several additional trees.

## **APPLICABLE CRITERIA - VARIANCE**

Class II Variance approvals are sought for the following:

- Class II Variance to allow on-site parking spaces to be located beyond the 200-foot maximum distance to the building entrance as required in CDC Section 46.070.
- Class II Variance to allow on-site bike parking spaces to be located beyond the 50-foot maximum distance to the building entrance as required in CDC Section 46.150.
- A Class II Variance to allow a wall sign of approximately 42 square feet where a maximum of 18 feet is required in CDC Section 52.300.

These variance requests must be found to comply with the criteria in CDC 75.020 B. 1. The variance criteria are noted below followed by the findings for each of the variance requests noted in the order above.

***Chapter 75 requires that a variance will only be approved if it meets four criteria:***

- 1. The variance is the minimum variance necessary to make reasonable use of the property.***

### On-site Parking Space Location

For a facility like a school, it is extremely difficult to get all parking spaces within 200 feet of the main entrance. This could be possible, but it would mean locating the main entrance a significant distance from the street and surrounding it with parking. The western parking lot could be brought closer to compliance, but it would mean that the



sports field would be removed from the school by a significant distance. The school is different from a commercial development, which would have multiple building entrances and the ability to locate all spaces within 200 feet of at least one entrance.

On-site Bike Parking Space Location

Bicycle use at primary schools is relative low, and it will tend to be somewhat higher during good weather. With this in mind, 20 of the required spaces are proposed within 50 feet of the building entrance. The remaining spaces are covered, but approximately 130 feet from the entrance. Unless the proposed canopy is made exceptionally large, providing the required covered bike spaces near the entrance would interfere with pedestrian access in and out of the school. The proposed arrangement offers a reasonable combination of convenience and secure bike parking.

Wall Sign Area

The purpose of the sign regulations is to ensure that signs are sufficient to identify different land uses in a tasteful way that is not visually obtrusive. While the wall sign is proposed to be larger than allowed, it will be complimentary to the school's design and the surrounding neighborhood.

Although the school would be entitled to multiple signs, it only needs one to identify the school for the general public. The proposed sign area of 28 square feet would be less than two conforming wall signs, which could total 36 square feet.

- 2. The variance will not result in violations(s) of any other code standard, and the variance will meet the purposes of the regulation being modified.***

On-site Parking Space Location

Except for the exception to allow 88 parking spaces instead of 97, the proposed parking will meet all city standards.

On-site Bike Parking Space Location

Except for not having all of the bike parking within 50 feet of the main entrance, the bike parking will meet all other city standards.

Wall Sign Area

The proposed signs for the school, including the wall sign and one, single-sided monument sign, will satisfy all other city requirements for signs. In addition, the entire signage program is well within the desired maximums for total number of signs and sign area.

- 3. The need for the variance was not created by the applicant and/or owner requesting the variance.***

The District did not create the need for the variances through any previous actions. The variances are requested to address unique conditions and desired design results for the school operation and appearance.

4. ***If more than one variance is requested, the cumulative effect of the variances results in a project that is consistent with the overall purpose of the zone.***

The three variances represent requests to allow modest deviations from the CDC standards to achieve a practical result that is in keeping with the purpose and intent of the CDC and West Linn Comprehensive Plan. The variances will allow the District to achieve a more desirable result regarding the location of parking and total sign area.

#### ***Chapter 99 Procedures for Decision-Making: Quasi-Judicial***

This chapter requires the applicant to contact the affected neighborhood to present the proposed development application. In addition to the required neighborhood meeting, the district held several neighborhood meetings to inform the community about the new school and to solicit input.

### **CONCLUSION**

The proposed applications satisfy the relevant criteria for approval. The long-awaited replacement of the Sunset Primary School will meet the needs of the students and neighborhood.

**EXHIBIT A**  
**Property Information**

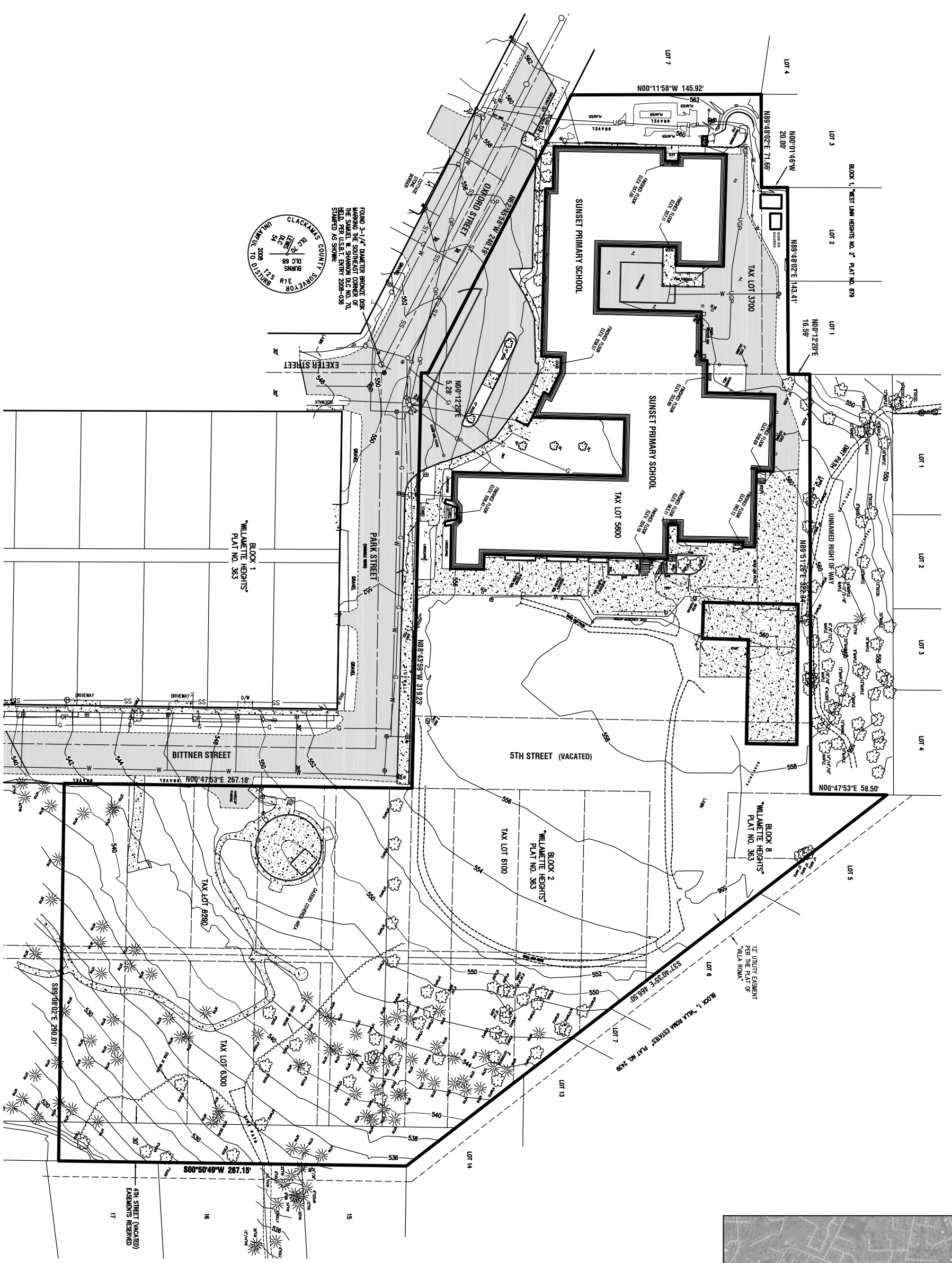
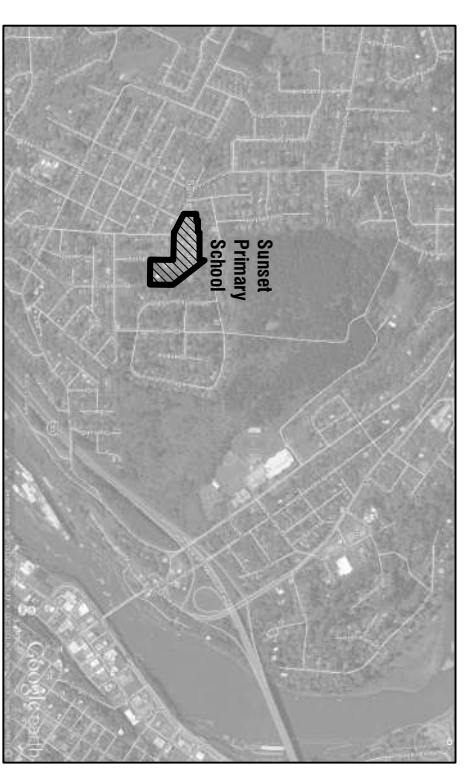

FOUND 3-1/4" DIAMETER BRONZE DISK MARKING THE SOUTHEAST CORNER OF THE SQUARE W. SWANSON D.C. NO. 70, BEING PERMITS CENTER 2006-038, STAKED AS SHOWN.

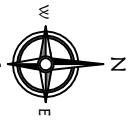

- Notes:**
1. BASIS OF ELEVATIONS IS NAVD '88 UTILIZING GPS OBSERVATIONS ON HIGH STATION "TEMP" IN OREGON CITY, UPRATED 2-25-08.
  2. CONTOUR INTERVALS ARE TWO FEET.
  3. SITE AREA = 273,468 SQUARE FEET (6.28 ACRES).

- Legend:**
- G GAS LINE
  - T OVERHEAD PHONE LINE
  - OP OVERHEAD POWER LINE
  - SS SANITARY SEWER LINE
  - ST STORM SEWER LINE
  - W WATER LINE
  - - - - - EDGE OF PARCEMENT

DATE	NO.	REVISION
DRAWN	MM/M	CHECK
SCALE	1" = 40'	DATE
PLAN	5367 Prelim Partition.dwg	

**COMPASS** Land Surveyors  
 4107 SE International Way, Suite 705  
 Milwaukie, Oregon 97222 503-653-9093

WEST LINN - WILSONVILLE SCHOOL DISTRICT  
 PO BOX 35  
 WEST LINN, OREGON 97068

**TENTATIVE PLAN**  
**FOR A ONE-PARCEL PARTITION PLAT**  
 SUNSET PRIMARY SCHOOL  
 2351 OXFORD STREET  
 WEST LINN, OREGON 97068

**EXHIBIT B**  
**Neighborhood Meeting**

**AFFIDAVIT**

I, Remo Douglas so hereby solemnly attest that the following statement is true.

Signage for the public notice of the West Linn – Wilsonville School District land use application presentation to the Sunset Neighborhood Association meeting was posted on or before October 20, 2015. A copy of the sign is attached.

Remo Douglas:  Date: 10-21-15

State of Oregon

County of Clackamas

Signed or attested before me on October 21, 2015  
by Remo Douglas, Notary Public State of Oregon.  
My Commission expires: March 22, 2019

Notary: 

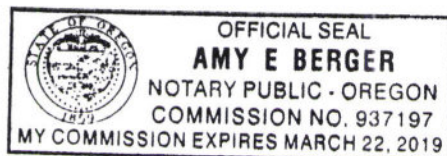

**AFFIDAVIT**

I, Remo Douglas so hereby solemnly attest that the following statement is true.

A copy of the letter to officers of the Sunset Neighborhood Association and property owners within 500 feet of the proposed structure was mailed on October 19, 2015. A copy of the mailing list with names and addresses is attached.

Remo Douglas: *R Dg* Date: 10-21-15

State of Oregon

County of Clackamas

Signed or attested before me on October 21, 2015  
by Remo Douglas, Notary Public State of Oregon.  
My Commission expires: March 22, 2019

Notary: *Amy E Berger*

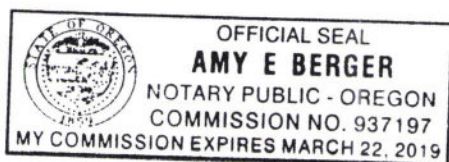



# CITY OF West Linn

## **PLANNING COMMISSION DECISION**

### **PROJECT #**

**CUP-15-03/DR-15-17/VAR-15-01/VAR-15-02/VAR-15-03**

### **CITIZEN CONTACT INFORMATION**

To lessen the bulk of agenda packets, land use application notice, and to address the worries of some City residents about testimony contact information and online application packets containing their names and addresses as a reflection of the mailing notice area, this sheet substitutes for the photocopy of the testimony forms and/or mailing labels. A copy is available upon request.





## West Linn – Wilsonville Schools

### PUBLIC NOTICE

**THE PUBLIC IS INVITED to attend a Sunset Neighborhood Association Meeting to discuss the proposed Construction of a New Sunset Primary School at West Linn – Wilsonville School District's Sunset Primary School site**

**November 10, 2015 at 7:00 pm  
Sunset Primary School  
2351 Oxford St  
West Linn, OR 97068**

#### **Property Information:**

- **LOCATION:** Sunset Primary School
- **ADDRESS:** 2351 Oxford St  
West Linn, OR 97068
- **DESCRIPTION:** Parcel Number 00386987  
Assessor's Map 21E25DC05800

#### **Improvements Description:**

The major elements of this work include:

- Construction of new Sunset Primary School at the current school site
- New playground and playfield
- New parking and student drop-off areas
- New sidewalks along school frontage

This is an informal meeting to discuss the improvements planned for the Sunset Primary School site. This meeting is in support of a Conditional Use and Class I Design Review application to the city of West Linn. The plan may be modified or altered prior to actual submittal.

For further information, please contact Amy Berger, West Linn – Wilsonville School District 503-673-7977; or visit us on the web at [www.bond.wlww.k12.or.us](http://www.bond.wlww.k12.or.us). Concerned citizens are also encouraged to contact their neighborhood association president, or their association designee, with any questions that they may want to relay to the school district.

Notice Dated October 20, 2015

U.S. Postal Service™  
CERTIFIED MAIL™ RECEIPT

(Domestic Mail Only; No Insurance Coverage Provided)

For delivery information visit our website at [www.usps.com](http://www.usps.com)®

OFFICIAL USE

Postage	\$ \$0.49
Certified Fee	\$3.30
Return Receipt Fee (Endorsement Required)	\$2.70
Restricted Delivery Fee (Endorsement Required)	\$0.00
Total Postage & Fees	\$ \$6.49



Sent To

RANDALL JAHNSON

Street, Apt. No.;  
or PO Box No.

4723 CORNWALL ST

City, State, ZIP+4

3/16/16 PC Meeting  
WEST LINN, OR 97068-3806

7009 0820 0000 9577 4448

## Certified Mail Provides:

- A mailing receipt
- A unique identifier for your mailpiece
- A record of delivery kept by the Postal Service for two years

### Important Reminders:

- Certified Mail may ONLY be combined with First-Class Mail® or Priority Mail®
- Certified Mail is *not* available for any class of international mail.
- NO INSURANCE COVERAGE IS PROVIDED with Certified Mail. For valuables, please consider Insured or Registered Mail.
- For an additional fee, a *Return Receipt* may be requested to provide proof of delivery. To obtain Return Receipt service, please complete and attach a Return Receipt (PS Form 3811) to the article and add applicable postage to cover the fee. Endorse mailpiece "Return Receipt Requested". To receive a fee waiver for a duplicate return receipt, a USPS® postmark on your Certified Mail receipt is required.
- For an additional fee, delivery may be restricted to the addressee or addressee's authorized agent. Advise the clerk or mark the mailpiece with the endorsement "*Restricted Delivery*".
- If a postmark on the Certified Mail receipt is desired, please present the article at the post office for postmarking. If a postmark on the Certified Mail receipt is not needed, detach and affix label with postage and mail.

**IMPORTANT:** Save this receipt and present it when making an inquiry.

PS Form 3800, August 2006 (Reverse) PSN 7530-02-000-9047

3/16/16 PC Meeting

U.S. Postal Service™  
CERTIFIED MAIL™ RECEIPT

(Domestic Mail Only; No Insurance Coverage Provided)

For delivery information visit our website at [www.usps.com](http://www.usps.com)®

OFFICIAL USE

Postage	\$ \$0.49
Certified Fee	\$3.30
Return Receipt Fee (Endorsement Required)	\$2.70
Restricted Delivery Fee (Endorsement Required)	\$0.00
Total Postage & Fees	\$ \$6.49



Sent To

DOUG & DOREEN VOKES

Street, Apt. No.;  
or PO Box No.

4972 PROSPECT ST

City, State, ZIP+4

WEST LINN, OR 97068-3125  
108

7009 0820 0000 9577 4455

## Certified Mail Provides:

- A mailing receipt
- A unique identifier for your mailpiece
- A record of delivery kept by the Postal Service for two years

### *Important Reminders:*

- Certified Mail may **ONLY** be combined with First-Class Mail® or Priority Mail®.
- Certified Mail is *not* available for any class of international mail.
- **NO INSURANCE COVERAGE IS PROVIDED** with Certified Mail. For valuables, please consider Insured or Registered Mail.
- For an additional fee, a *Return Receipt* may be requested to provide proof of delivery. To obtain Return Receipt service, please complete and attach a Return Receipt (PS Form 3811) to the article and add applicable postage to cover the fee. Endorse mailpiece "Return Receipt Requested". To receive a fee waiver for a duplicate return receipt, a USPS® postmark on your Certified Mail receipt is required.
- For an additional fee, delivery may be restricted to the addressee or addressee's authorized agent. Advise the clerk or mark the mailpiece with the endorsement "*Restricted Delivery*".
- If a postmark on the Certified Mail receipt is desired, please present the article at the post office for postmarking. If a postmark on the Certified Mail receipt is not needed, detach and affix label with postage and mail.

**IMPORTANT:** Save this receipt and present it when making an inquiry.

PS Form 3800, August 2006 (Reverse) PSN 7530-02-000-9047

3/16/16 PC Meeting  
109



# USPS Tracking®



[Customer Service >](#)

Have questions? We're here to help.



[Get Easy Tracking Updates >](#)

Sign up for My USPS.

**Tracking Number:** 70090820000095774455

## Product & Tracking Information

**Postal Product:**

**Features:**  
Certified Mail™

DATE & TIME	STATUS OF ITEM	LOCATION
October 21, 2015 , 11:05 am	Delivered	WEST LINN, OR 97068
Your item was delivered at 11:05 am on October 21, 2015 in WEST LINN, OR 97068.		
October 20, 2015 , 5:55 pm	Departed USPS Facility	PORTLAND, OR 97220
October 20, 2015 , 1:58 pm	Arrived at USPS Facility	PORTLAND, OR 97220
October 19, 2015 , 11:59 pm	Departed USPS Facility	PORTLAND, OR 97208
October 19, 2015 , 11:26 pm	Arrived at USPS Facility	PORTLAND, OR 97208

## Available Actions

[Text Updates](#)

[Email Updates](#)

## Track Another Package

**Tracking (or receipt) number**

[Track It](#)

## Manage Incoming Packages

Track all your packages from a dashboard. No tracking numbers necessary.

[Sign up for My USPS >](#)



### HELPFUL LINKS

- [Contact Us](#)
- [Site Index](#)
- [FAQs](#)

### ON ABOUT.USPS.COM

- [About USPS Home](#)
- [Newsroom](#)
- [USPS Service Updates](#)
- [Forms & Publications](#)
- [Government Services](#)
- [Careers](#)

### OTHER USPS SITES

- [Business Customer Gateway](#)
- [Postal Inspectors](#)
- [Inspector General](#)
- [Postal Explorer](#)
- [National Postal Museum](#)
- [Resources for Developers](#)

### LEGAL INFORMATION

- [Privacy Policy](#)
- [Terms of Use](#)
- [FOIA](#)
- [No FEAR Act EEO Data](#)



# USPS Tracking®



[Customer Service >](#)

Have questions? We're here to help.



[Get Easy Tracking Updates >](#)

Sign up for My USPS.

**Tracking Number:** 70090820000095774448

## Product & Tracking Information

**Postal Product:**

**Features:**

Certified Mail™

## Available Actions

[Text Updates](#)

[Email Updates](#)

DATE & TIME	STATUS OF ITEM	LOCATION
October 21, 2015 , 1:22 pm	<b>Delivered</b>	<b>WEST LINN, OR 97068</b>
Your item was delivered at 1:22 pm on October 21, 2015 in WEST LINN, OR 97068.		
October 20, 2015 , 5:55 pm	Departed USPS Facility	PORTLAND, OR 97220
October 20, 2015 , 1:58 pm	Arrived at USPS Facility	PORTLAND, OR 97220
October 19, 2015 , 11:59 pm	Departed USPS Facility	PORTLAND, OR 97208
October 19, 2015 , 11:27 pm	Arrived at USPS Facility	PORTLAND, OR 97208

## Track Another Package

**Tracking (or receipt) number**

[Track It](#)

## Manage Incoming Packages

Track all your packages from a dashboard. No tracking numbers necessary.



[Sign up for My USPS >](#)

### HELPFUL LINKS

- [Contact Us](#)
- [Site Index](#)
- [FAQs](#)

### ON ABOUT.USPS.COM

- [About USPS Home](#)
- [Newsroom](#)
- [USPS Service Updates](#)
- [Forms & Publications](#)
- [Government Services](#)
- [Careers](#)

### OTHER USPS SITES

- [Business Customer Gateway](#)
- [Postal Inspectors](#)
- [Inspector General](#)
- [Postal Explorer](#)
- [National Postal Museum](#)
- [Resources for Developers](#)

### LEGAL INFORMATION

- [Privacy Policy](#)
- [Terms of Use](#)
- [FOIA](#)
- [No FEAR Act EEO Data](#)

## **2<sup>nd</sup> Special Sunset Neighborhood Association Meeting Minutes**

November 10, 2015

Location: Sunset Primary School - cafeteria

### **CALL TO ORDER**

Doreen Vokes, Secretary/Treasurer, of the Sunset Neighborhood Association (SNA), called the meeting to order at 7:05 p.m.

### **PRESENT**

21 members and guests: WLWV School District representatives and DOWA-IBI Group Architects

The meeting attendance sign-in sheet is in our files and is available upon request.

### **NO SECRETARY OR TREASURER REPORT GIVEN.**

### **SUNSET SCHOOL DISCUSSION:**

The DOWA-IBI Group Architects displayed designs of the new Sunset Primary School to those in attendance. The designs included an overhead view, layouts for both floors, locations and sizes of play field and parking lot, playground equipment configurations, and fire access lanes. Also shown were perspective street level views looking toward the main entrance.

Tim Woodley, Director of Operation, opened the meeting by talking about the history of the school, ballot measures, and the task force that lead to the decision to keep the school at the Oxford St location. He presented via Power Point the latest design and noted the various changes:

- Moved 8 parking spots from the south lot to the western lot
- With the City allotted 10% reduction, the total new parking spots would now be 88 instead 97, if approved.
- New on-street parking on Oxford St, Park St, and Bittner, including sidewalks
- A multi-way stop at the intersection of Oxford, Park and Exeter St
- Storm planter detention area near the south parking lot
- The school district will talk to every neighbor whose property abuts the school district property to help with creating a buffer zone such as fencing, trees, shrubbery, etc.

### **Concerns and questions brought up:**

1. Number of new on-street parking spaces created on the streets? Unknown
2. Would those parking spaces offset the required number of spaces on the school property? No
3. Why is there a new design for each meeting? That's part of the iterative design process.
4. Why is the school being designed for 450 students? It supports the number of kids within the Sunset boundary.
5. How much smaller will the field be after reduction? No full size baseball field
6. Security concerns? Police will have access to the playground; cameras installed



7. It was mentioned that the deed for the property has a restriction that the Sunset Park property purchased by the school is to be used only for recreation purposes. Note that the original property was deeded to the City by Crown Zellerbach, now Georgia Pacific. Mr. Woodley felt that the land usage is covered by the (IGA) Inter Governmental Agreement signed as part of the land sale.
8. Will remnants of the old school be displayed in the new structure? Yes
9. Over-all security for the occupants of the building? A portion of the money for the bond is to hire a National School Safety Consultant. The front door to the building might be controlled with possible card access, security cameras, etc. Mr. Woodley has been meeting with the Clackamas County Sheriff Dept. to help formulate a security plan for all the schools within the Clackamas area. It is anticipated that the concepts developed here will become a model for the state of Oregon.

The design shown today will be part of the package submitted to the city planning department. Once all the paperwork has been finalized, there will be a four month window for additional public input. The school would like to begin construction June, 2016.

The parks and recreation department supervisor Ken Worcester has agreed to attend our next neighborhood meeting in January to discuss the new master plan for Sunset Park.

## ADJOURNMENT

With no further business before the SNA, the President adjourned the meeting at 8:20pm.

**\*\*Next quarterly meeting Tuesday, January 26, 2016 @ 7pm\*\***

Respectfully submitted by Doreen Vokes, Secretary of the SNA.

Association info and meeting minutes, or for general City information, Visit [www.ci.west-linn.or.us](http://www.ci.west-linn.or.us) Please see the link for our new Facebook page <https://www.facebook.com/sunsetneighborhoodwestlinn>

## SNA OFFICERS

President,	Randall Jahnsen	<a href="mailto:SunsetNA@westlinnoregon.gov">SunsetNA@westlinnoregon.gov</a>
Vice President,	<i>open</i>	<a href="mailto:SunsetNA@westlinnoregon.gov">SunsetNA@westlinnoregon.gov</a>
Secretary/Treasurer,	Doreen Vokes	<a href="mailto:SunsetNA@westlinnoregon.gov">SunsetNA@westlinnoregon.gov</a>

For association info and meeting minutes, or for general city information, visit

[www.westlinnoregon.gov](http://www.westlinnoregon.gov)

**EXHIBIT C**  
**Sunset Primary School Transportation Analysis and**  
**Safe Routes to School Plan**



117 Commercial Street NE  
Suite 310  
Salem, OR 97301  
503.391.8773  
www.dksassociates.com

## MEMORANDUM

**DATE:** November 23, 2015

**TO:** Remo Douglas, West Linn-Wilsonville School District

**FROM:** Scott Mansur, P.E. *Sm*  
Jordin Ketelsen, E.I.T.

**SUBJECT:** **Sunset Primary School Transportation Analysis and Safe Routes to School Plan** P15142-001

A bond was recently passed for the West Linn-Wilsonville School District which created funding to replace Sunset Primary School (K-5). The school is located at 2351 Oxford Street in the City of West Linn, Oregon. As part of this school replacement, the City of West Linn agreed to sell 1.6 acres of Sunset Park to the school district thereby creating adequate land to rebuild on the same site. The school boundary extends to the south to I-205, to the east to West A Street, west to Wild Rose Drive, and to the north near Rosemont Road. Oxford Street provides access to the current school site and is classified as a Neighborhood Route by the City of West Linn. Details regarding the existing conditions project trip generation, safe routes to school assessment, site circulation and loading review, and project recommendations summary can be found in the following sections.



### Existing Conditions

Evaluation of the existing pedestrian and bike environment can be used to identify where gaps in the network exist as well as identify locations where improvements are needed to improve safe routes to Sunset Primary School. Identifying the key routes that Sunset Primary School students are most likely to frequent while traveling to and from school will also be considered to improve safety for the high use facilities and accessibility.

### ***Existing Sidewalk Connectivity***

The existing sidewalk inventory can be seen in Figure 1. As shown, the only streets that have complete sidewalks on both sides of the facility are to the northeast of the school including Windsor Terrace, Clark Street, Crown Street, and Kobuk Court. Many significant sidewalk gaps exist within the walking boundary, especially in the immediate vicinity of Sunset Primary School between Cornwall Road and Walden Road. Furthermore, as shown in the image to the top right, the existing sidewalks are in poor condition, are very narrow, and have frequent gaps. The lack of standard sidewalks, narrow streets, and lack of bike facilities is likely due to the age of the surrounding neighborhood.



**Existing Sidewalk Quality in the School's Vicinity**

Sunset Park is directly adjacent to the existing Sunset Primary School building and has several paths connecting neighborhoods to Sunset Primary School via Sunset Park. One path connects from the east side of Sunset Park to Windsor Terrace (see figure in the bottom right). Another pedestrian path exists north of the existing Sunset Primary School and connects to Windsor Terrace. These paths do not have any pathway lighting and do not meet ADA standards. Two additional paths on the south side of Sunset Park connect to Long Street but are not ADA accessible.



**Pedestrian Path Connecting Windsor Terrace to Sunset Park**

### ***School Crossing Evaluation***

Two marked crossings currently exist adjacent to Sunset Primary School; one on the west leg of the Sussex Street/Oxford Street intersection and one on the east leg of the Exeter Street/Oxford Street intersection. As shown in the figures at the top of the next page, the Sussex Street crossing does not connect to any sidewalks on Sussex Street and the Exeter Crossing does not directly connect to the building causing students to also have to cross the busy drop off entrance before reaching the School's sidewalks. The south leg of this crossing (Exeter Street) does have sidewalks.

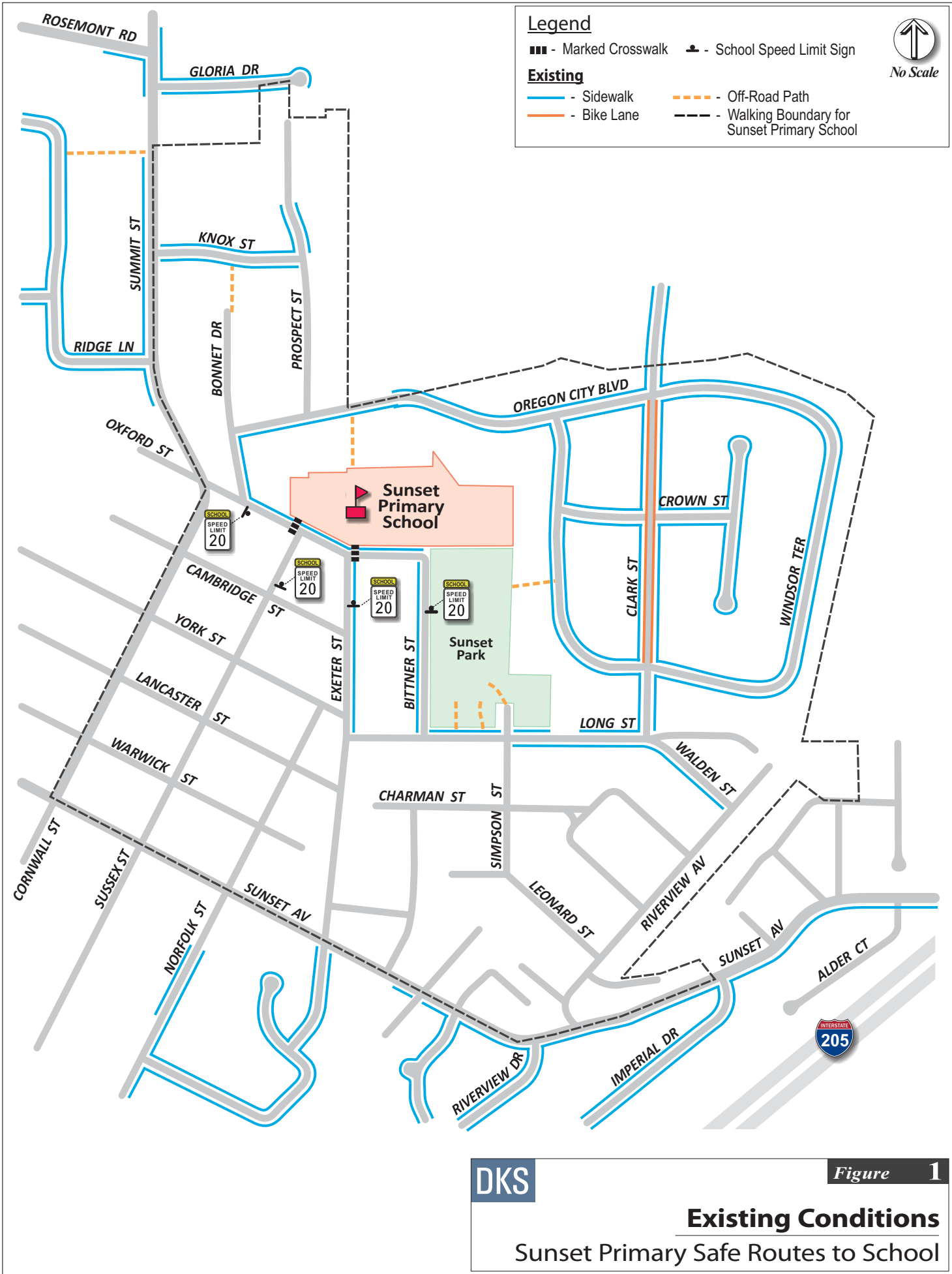

No Scale

DKS

Figure 1

**Existing Conditions**

**Sunset Primary Safe Routes to School**



**Sussex Crossing with No Sidewalks on South Side**



**Exeter Crossing does not Connect Directly to the Building**

### ***School Speed Zone Evaluation***

Due to the residential land uses surrounding the school, the posted speed along the majority of the roads within the walking boundary are 25 mph which is the default statutory speed for a residential street.<sup>1</sup> School zones (speed 20 mph) are signed adjacent to Sunset Primary School along Oxford Street as well as the approaches to Oxford Street on Sussex Street, Exeter Street, and Bittner Street.

### ***Existing Bicycle Network***

Bike lanes currently exist along Clark Street between Long Street and Windsor Terrace (See Figure 1). No other bike facilities currently exist within the Sunset Primary School walking boundary.

---

<sup>1</sup> Speed Zoning Program. ODOT Traffic-Roadway Section (TRS). [http://www.oregon.gov/odot/hwy/traffic-roadway/pages/speed\\_zone\\_program.aspx](http://www.oregon.gov/odot/hwy/traffic-roadway/pages/speed_zone_program.aspx). Accessed June 20, 2012.



## Trip Generation

Trip generation estimates were performed for the existing Sunset Primary School to provide a baseline for determining how the proposed replacement would affect traffic to and from the site. The traffic impacts for the existing school and the proposed rebuild is discussed in the following sections.

### Existing Trip Generation

The trip generation estimates for the existing Primary School were performed using rates obtained from the Institute of Transportation Engineers (ITE), *Trip Generation, 9<sup>th</sup> Edition*.<sup>2</sup> The architectural capacity of the current school is 575 students<sup>3</sup>. Even though the highest historical enrollment at the school was only 471 students, the architectural capacity of the existing Sunset Primary School was the maximum enrollment utilized to estimate traffic impacts of the existing site to ensure an equal comparison with the architectural capacity of the proposed replacement. As shown in Table 1, the existing school’s trip generation is estimated to be 259 a.m. peak hour trips, 86 p.m. peak hour trips and approximately 742 daily trips.

**Table 1: Existing Trip Generation**

Peak Hour	Land Use (ITE Code)	Size	Trip Rate	Peak Hour Trips
AM	Elementary School (520)	575 Students	0.45 trips/student	259 (142 in, 117 out)
PM			0.15 trips/student	86 (42 in, 44 out)
Daily			1.29 trips/student	742 Daily Trips

### Proposed Trip Generation

Trip generation estimates were also performed for the proposed replacement using applicable ITE rates. Based on information provided by the School District, the future Sunset Primary School building will have an architectural capacity of 450 students (125 less students than the existing building). As shown in Table 2, it is estimated that the proposed rebuild would generate 581 daily trips, 203 a.m. peak hour trips and 68 p.m. peak hour trips. As shown, the proposed replacement would add less total traffic to the study area network than the Sunset Primary School historical use for both the architectural capacity and the historical maximum capacity.

**Table 2: Proposed Land Use Trip Generation**

Peak Hour	Land Use (ITE Code)	Size	Trip Rate	Peak Hour Trips	Net Effect
AM	Elementary School (520)	450 Students	0.45 trips/student	203 (112 in, 91 out)	-56 trips
PM			0.15 trips/student	68 (33 in, 35 out)	-18 trips
Daily			1.29 trips/student	581 Daily Trips	-161 trips

<sup>2</sup> *Trip Generation, 9<sup>th</sup> Edition*, Institute of Transportation Engineers, 2012.

<sup>3</sup> Email conversation with Remo Douglas, West Linn-Wilsonville School District, June 29, 2015.



## **Site Plan Review**

The site plan provided by the School District<sup>4</sup> was evaluated to identify potential concerns related to site access, intersection sight distance, school speed zone, bus loading, parent loading, pedestrian and bicycle access, bicycle parking, site parking needs, and frontage improvements. A copy of the site plan is included in the appendix.

### ***Site Access***

The preliminary site plan includes three proposed driveways; two via Oxford Street aligned with Exeter Street and Sussex Street and one via Bittner Street approximately 375 feet from the easternmost Oxford Street Driveway. Minimum access spacing along Oxford Street (classified as a neighborhood route) is desired at 100 feet and a 50 foot minimum access spacing is desired for Bittner Street (classified as a local residential street).<sup>5</sup> The location of the proposed accesses as shown in the site plan meets City spacing requirements. Additionally, the westernmost proposed access on Oxford Street is recommended to align with Sussex Street to reduce any intersection offset.

### ***Intersection Sight Distance***

Preliminary sight distance at each access was evaluated and found to be sufficient for all movements in and out of each driveway. However, at the time that the project site is constructed, sight distance at all proposed project access points will need to be verified, documented, and stamped by a registered professional Civil or Traffic Engineer licensed in the State of Oregon prior to occupancy.

### ***School Speed Zones and Posted Speed***

ODOT's guide to school area safety<sup>6</sup> provides guidance on the application of reduced school speed zones along roadways adjacent to middle and primary schools. During school hours Oxford Street, Bittner Street, Exeter Street, and Sussex Street are currently posted as a school speed zone 20 mph in the immediate vicinity of the Sunset Primary School building. It is recommended that the existing school speed zones be replaced and enforced with school speed zone flashers consistent with operations at other similar primary schools in the West Linn-Wilsonville School District. Furthermore, the location of the existing school speed zone sign on Bittner Street is recommended to relocate to the corner of Bittner Street and Long Street to expand the school speed zone based on the proposed site modifications of the rebuild (see Figure 2 in the Safe Routes to School Assessment section of this memorandum).

---

<sup>4</sup> Site Plan for Sunset Primary School provided via email by Rebecca Stuecker, IBI Group Architects, November 16, 2015.

<sup>5</sup> *West Linn Transportation System Plan*, Chapter 8, December 2008.

<sup>6</sup> *A Guide to School Area Safety*, Oregon Department of Transportation, July 2006 revised February 2009.





During the 2011 legislative session, House Bill (HB) 3150 was signed into law by the Governor. HB 3150 allows the road authority to establish by ordinance a designated speed for a roadway under their jurisdiction that is five miles per hour lower than the statutory speed.<sup>7</sup> Additional stipulations to this authority are that the roadway is located in a residence district, it has average volumes fewer than 2,000 motor vehicles per day, and more than 85 percent of which are traveling less than 30 MPH. Since Sussex Street, Exeter Street, Lancaster Street, Leonard Street, Simpson Street, and Long Street meet the criteria of HB 3150, the City could consider lowering the posted speed from 25 MPH to 20 MPH in the vicinity of Sunset Primary School. Lowering the posted speed has been shown to reduce crash severity and will improve the safe routes for pedestrians and bicyclists.

### ***Bus Loading***

Based on the site plan, buses will pick up and drop off students along the school frontage between the proposed access on Bittner Street and the proposed accesses on Oxford Street that aligns with Exeter Street. The buses would enter the pick-up/drop-off zone via Bittner Street onto Oxford Street, and exit along Oxford Street toward the west project access. The new bus loading area includes approximately 300 feet of curb space along the frontage of the school, which is more than sufficient for the estimated 5 buses expected to better serve the school<sup>8</sup> (assuming a 40 foot design length and ten foot spacing<sup>9</sup>). Based on the site plan, the proposed on-street bus loading area provides sufficient space for student loading while allowing adequate space for two-way motor vehicle traffic along Oxford Street.

### ***Parent Loading***

The current site plan provides a designated parent loading area on Oxford Street west of the proposed project access that aligns with Sussex Street as well as the space on Bittner Street behind the buses in the bus loading area. Parents would enter the pick-up/drop-off zones going northbound on Bittner Street, and exit going west on Oxford Street.

The designated parent loading area on Oxford Street includes approximately 150 feet of curb space along the frontage of the school and approximately 100 feet of curb space along Bittner Street is expected to be available behind the five buses in the bus loading zone which is sufficient for approximately ten vehicles (assuming 25 feet per vehicle). Clear delineation should be provided between the designated bus loading and parent loading along Bittner Street and Oxford Street between the south and east project accesses. It also important to note that additional parent loading space is available on Oxford Street west of Sussex Street if the designated parent loading spaces reach capacity.

---

<sup>7</sup> Enrolled House Bill 3150. Oregon Legislature. <http://www.leg.state.or.us/11reg/measpdf/hb3100.dir/hb3150.en.pdf>. Accessed June 20, 2012.

<sup>8</sup> Five bus routes serve Sunset Primary School including routes 27, 30, 50, 51, and 52.

<sup>9</sup> *Geometric Design of Highways and Streets*, AASHTO, 2011; Figure 2-8, p. 2-17.



A raised pedestrian crossing across the proposed east access on Oxford Street is recommended. This would allow for students to exit the parent loading area and access the school building with no change in grade, as well as reducing the speeds of motor vehicle entering the driveway.

***Pedestrian and Bicycle Access***

A sidewalk on both sides of Bittner Street and Oxford Street is shown along the extents of the project frontage. It is recommended to have marked pedestrian crossings on each leg of the proposed access on Oxford Street that aligns with Exeter Street as well as the south leg of the proposed access on Bittner Street. The provision of connected facilities improves safety and also encourages walking and bicycling to school, which are important travel modes for students who live close to the school.

***Site Parking Needs***

There are currently only 27 regular parking stalls incorporated in the existing Sunset Primary School which is below the City of West Linn’s minimum parking standards. The future configuration of Sunset Primary School proposes a total of 91 parking stalls even though it is decreasing in both size and classrooms. The proposed 91 parking stalls for the future configuration of Sunset Primary School and the City’s vehicular parking requirements<sup>10</sup> are shown in Table 3 below.

**Table 3: Vehicular Parking Summary**

<b>Scenario</b>	<b>Number of Parking Stalls</b>
City Minimum Requirements	97
Future Proposed Parking	91
<b>Net Parking Deficiency</b>	<b>6</b>

---

<sup>10</sup> The City of West Linn’s minimum parking standards for primary schools are based on the number of employees and building square footage.



As shown, the proposed 91 parking stalls still falls short nine stalls from the City’s parking requirements. However, it does bring Sunset Primary School closer to conformance with City code. Furthermore, the current site plan states that an intentional reduction of the six stalls required was made in order to preserve existing trees.<sup>11</sup> If additional parking demand is needed, on-street parking along residential streets in the vicinity of Sunset Primary School is available.

Table 4 shows the minimum bicycle parking requirements compared with the proposed bicycle parking facilities for the future Sunset Primary School. As shown, the site plan shows sufficient bicycle parking for the primary school.

**Table 4: Bicycle Parking Summary**

Land Use	Size	Bicycle Parking		
		<i>City Code Requirement</i>	<i>Minimum Spaces</i>	<i>Proposed Spaces</i>
<b>Primary School</b>	18 classrooms	2 spaces per class	36	40

## Safe Routes to School Assessment

Based on the evaluation of the existing conditions assessment, recommendations to improve connectivity and safety in the Sunset Primary School walking boundary have been developed. Recommendations regarding pedestrian and bicycle connectivity are shown in Figure 2 and discussed in the following sections.

### ***Sidewalk Infill***

As was shown in Figure 1, significant gaps in the sidewalk system exists in the vicinity of Sunset Primary School. Children within the walking boundary are not provided bus transportation to school, as such; recommendations for sidewalk infill have been identified at the end of the memorandum. Sidewalk infill locations can be seen in Figure 2. Sidewalk infill is being recommended along key walking routes primarily in the southeast, southwest, and northwest areas of the Sunset Primary walking boundary to improve safety for residents in these areas.

Key sidewalk connectors include Summit Street, Bonnet Drive, Bittner Street, Sussex Street, Long Street, Riverview Avenue, Leonard Street, and Simpson Street. Additionally, lighting along the off street path that connects Windsor Terrace to Sunset Park and that connects Windsor Terrace to the Sunset Primary school campus would make these pathways more attractive walking options for students that live in the neighborhoods north and east of Sunset Primary School.

---

<sup>11</sup> CDC55.170



No Scale

### Legend

- ▬ - Marked Crosswalk
- ⬇ - School Speed Limit Sign
- ◀ - Proposed Access Points

### Existing

- - Sidewalk
- - Bike Lane
- - Off-Road Path
- - - - - Walking Boundary for Sunset Primary School

### Recommended

- ⋯ - Sidewalk Infill -- *Recommendations*
- █ - TSP Sidewalk Infill -- *Previously Identified*

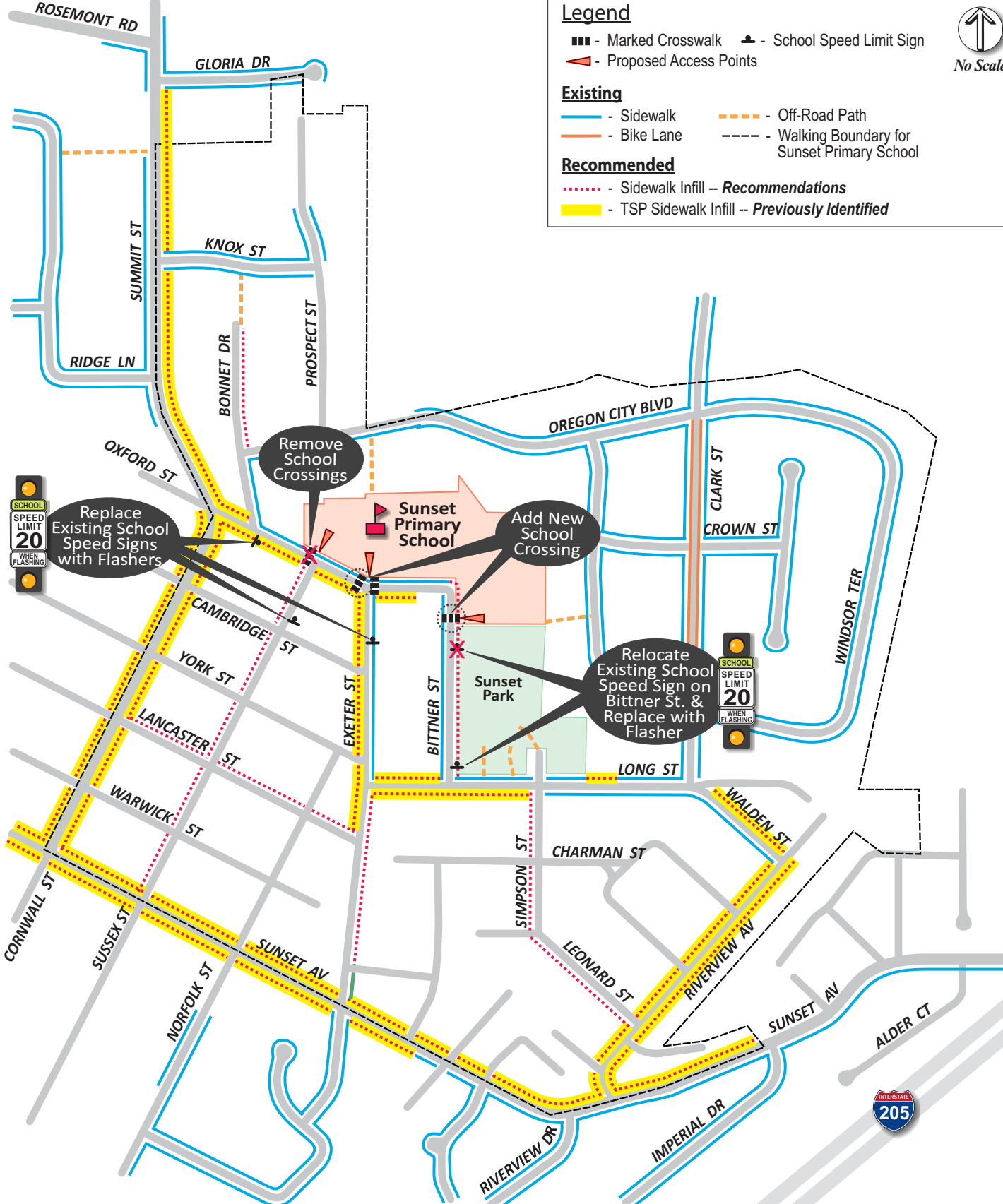

DKS

Figure 2

## Recommendations

3/16/16 PC Meeting  
124

Sunset Primary Safe Routes to School



### ***Crosswalk Pavement Markings***

Changes to the key crossing locations are also being recommended based on the sidewalk infill recommendations and changes to the school building location. The proposed crosswalk locations can be seen in Figure 2. As shown, additional crossings at the Sussex Street/Oxford Street and Exeter Street/Oxford Street crossings are recommended to better serve the new school layout. These marked crosswalks will help to facilitate connectivity at key locations for children walking to and from the rebuilt Sunset Primary School. A crossing was not recommended at the Bittner Street/Oxford Street curve due to sight distance issues.

### ***Bicycle Connectivity***

Since Bittner Street, Oxford Street, Sussex Street, Exeter Street, Lancaster Street, Leonard Street, Simpson Street, and Long Street are low volume roadways, they are preferred routes for bicyclists to travel to Sunset Primary School. To enhance the awareness of potential bicyclists in the vicinity of the school, pavement markings could be added to these streets to provide a clear understanding as to which facilities bikes would use to access the school.

The City of West Linn follows guidelines presented in their Bicycle Master Plan, as well standards from the AASHTO Guide to Bicycle Facilities, the Oregon Bicycle and Pedestrian Plan, and the Manual on Uniform Traffic Control Devices (MUTCD). The 2009 MUTCD recommends using the more visible Shared Lane Marking (Sharrow).<sup>12</sup> Based on our evaluation of both roadways, and to be consistent with current standards, Sharrow lane markings could be added along the aforementioned roadways to better define a bicycle path from the residential neighborhoods to Sunset Primary School.

The West Linn TSP also calls out a need for bike lines on both sides of Summit Street from Skyline Drive to Cornwall Street and on Sunset Avenue from Parker Road to Willamette Falls Drive. On-street bike lanes on these key connectors would enhance the comfort and safety of bicyclists in the vicinity of Sunset Primary School.

---

<sup>12</sup> Part 9 – Traffic Control for Bicycle Facilities, Figure 9C-9. Shared Lane Marking. Manual on Uniform Traffic Control Devices. <http://mutcd.fhwa.dot.gov/pdfs/2009/part9.pdf>. Accessed June 21, 2012.



## Project Recommendations Summary

Several projects are recommended as a result of the safe routes to school analysis for Sunset Primary School. These projects are listed in Table 5 below. Note that the following projects are not listed in order of priority and project numbers should be used for reference only.

**Table 5: Project Recommendations**

Roadway	From	To	Project Type	
<i>School Crosswalks</i>				
1	Bittner Street	-	-	Add new school crossing
2	Oxford Street (East Access)	-	-	Add new school crossing
<i>School Speed Zones</i>				
3	School Speed Zone Improvements	-	-	Replace existing school speed signs with flashers
<i>Sidewalk Infill</i>				
5	Bittner Street	Long Street	Oxford Street	Sidewalk infill - east side
6*	Oxford Street	Sussex Street	Proposed School Crossing	Sidewalk infill - south side
7	Bonnet Drive	Beginning of Road	Windsor Terrace	Sidewalk infill - east side
8*	Summit Street	Gloria Drive	Knox Street	Sidewalk infill - east side
9*	Long Street	Clark Street	Simpson Street	Sidewalk infill - north side
10	Simpson Street	Leonard Street	Long Street	Sidewalk infill - west side
11	Leonard Street	Riverview Avenue	Simpson Street	Sidewalk infill - west side
12*	Riverview Avenue	Sunset Avenue	Leonard Street	Sidewalk infill - north side
13	Sussex Street	Sunset Avenue	Oxford Street	Sidewalk infill - west side
14*	Summit Street	Knox Street	Oxford Street	Sidewalk infill - east side
15*	Long Street	Simpson Street	Exeter Street	Sidewalk infill - south side
16	Lancaster Street	Cornwall Street	Exeter Street	Sidewalk infill - north side
17	Exeter Street	Sunset Avenue	Long Street	Sidewalk infill - west side
18*	Riverview Avenue	Walden Street	Leonard Street	Sidewalk infill - north side
19*	Sunset Avenue	Imperial Drive	Cornwall Street	Sidewalk infill - both sides
20*	Cornwall Street	Sunset Avenue	Oxford Street	Sidewalk infill - both sides
21*	Oxford Street	Cornwall Street	Sussex Street	Sidewalk infill - south side
22*	Exeter Street	Lancaster Street	Oxford Street	Sidewalk infill - west side
23*	Long Street	Exeter Street	Bittner Street	Sidewalk infill - north side
24*	Riverview Avenue	Sunset Avenue	Walden Street	Sidewalk infill - west side
25*	Walden Street	Riverview Avenue	Long Street	Sidewalk infill - west side

\* Identified in the City of West Linn's TSP as part of the Pedestrian Master Plan.

**EXHIBIT D**  
**Arborist Report**



November 20, 2015

Remo Douglas  
Project Manager  
West Linn-Wilsonville School District  
2755 Borland Rd  
Tualatin, OR 97062

**Project: Sunset Primary School located at 2351 Oxford Street, West Linn, OR**

Enclosed is the certified arborist report and tree protection plan regarding the rebuilding of Sunset Primary School located at 2351 Oxford Street in the West Linn-Wilsonville School District that complies with West Linn Municipal code.

**Summary**

Initially the majority of the large, significant trees on the site would be retained on the property. Both architect firms; Dull Olson Weekes Architects & Walker Macy Landscape Architects have done an excellent job of reworking blue prints to minimize the number of trees requiring removal or being impacted by the project. These reconfigurations should help ease the mind of neighbors with concerns.

Early blue prints call for removal of only two healthy native trees. One maple will be damaged with the demolition of the building and a second is a border tree on the edge of the eastern forest area.

Under that plan only (34) trees are scheduled for removal. These include:

- ◆ (5) pin oaks in the turf (messy, high maintenance trees)
- ◆ Forest Perimeter Trees
  - (4) maples (Three of which are in decline with significant dead crown)
  - (9) cherries (not alders) ( all leaning at approximately 45 degree angle seeking light)
- ◆ Around School
  - (2) cherries on east side(not apple)
  - (1) 26” DBH maple at back corner too close to building (not alder)
  - (7) styrax across front
  - (2) cherries in front island

*www.generaltree.com - customerservice@generaltree.com - Phone (503) 656-2656 - Toll Free 1-888-656-5401  
Fax (503) 656-3219 - 6795 SW 111th Ave. Beaverton Oregon 97008 - CCB#63604 LCB#5814*

**“Our Business is Growing Great Relationships!”**





- (1) hinoki cypress in front
- (3) pin oaks in court yard

Unfortunately, with the updated redesign dictated by the city engineers, nine additional trees need to be removed to accommodate the runoff holding pond/bio-swale.

- ◆ (2) 33” DBH Douglas firs are in line with piping
- ◆ (7) more Douglas firs ranging in DBH ranging from 24-36” are in the pond zone

It is my recommendation to remove at least (17) more hazardous trees and consider (4) others\*. These include:

- ◆ Forest
  - Non tagged damaged flowering plum
  - #4426 Douglas fir snag
  - #4572 Douglas fir with dead top
  - #4597 small dead Douglas fir
  - #4595 small dying big leaf maple (not cottonwood)
  - #4118 dead maple just south of main forest
- ◆ North side of property
  - Outside of fence by covered play area
    - (8) damaged big leaf maples with decay and lean over property (pink dots)
  - Outside fence
    - \*The next (2) big leaf maples are in better shape, but due to their size (24” & 26” DBH ) and condition should be considered for removal
    - (3) Lombardy poplars ( approximate 12, 18, & 30”DBH) are in serious decline, pose a threat and owner is in agreement about removal need
    - \*(1) healthier approximately 36” DBH Lombardy poplar, just west of others, should be considered due to species and their short life
  - Inside fence
    - \*(1) young healthy 24” Lombardy popular-due to nature of tree

The eastern forest will need to be cleaned up. Invasive understory shrubs will need to be removed. Ivy needs to be removed from trunks of the trees so further evaluation can be made. Large Douglas firs and big leaf maples will need closer inspection and maintenance pruning and fertilization to reduce hazards and help them adapt to change.

As long as the protection plan is enforced and the forest stand is not disturbed, other than careful maintenance following arboricultural standards, the trees should do well. It will also be important

*www.generaltree.com - customerservice@generaltree.com - Phone (503) 656-2656 - Toll Free 1-888-656-5401  
Fax (503) 656-3219 - 6795 SW 111th Ave. Beaverton Oregon 97008 - CCB#63604 LCB#5814*

**“Our Business is Growing Great Relationships!”**



to maintain the current grade near the trees. Water flow through the site will need to be managed to ensure that surfaces and below ground flows are not significantly altered from current levels. The impact to neighborhood trees should be minimal. On the east side there should not be any impact. On the north boundary many of the trees are in poor condition. Exposing these trees could lead to failure.

### **Assignment**

1. Certify the trees on site and their condition, note trees of unique significance
2. Review conditions and impact to trees on the adjacent north property line
3. Review the impact of proposed tree removals on groves
4. Recommend tree protection measures to protect trees that will remain on site
5. Assessment and recommendations for invasive species removal
6. Assessment for potentially hazardous trees and conditions
7. Recommendations for tree and plant removal methods within existing forest

### **Report Purpose**

The report is to certify the trees that are on site as well as their condition and to outline the tree protection steps needed to protect the trees. This report is written to meet all the requirements for tree protection on properties being developed in the City of West Linn.

### **Observations**

The property was walked on October 16, 2015 with project manager and project architects. Blue prints and overlays were studied. The tree inventory list of trees in the forest and park area was reviewed. This list was compiled in March of 2015 by Compass Land surveyors. Due to dormant season identification, a few trees were misnamed. Trees 4119, 4120, and 4121 are not alders, they are cherries. The trees surrounding the existing school are not numbered but can be clearly identified on the map. There a couple discrepancies of species that include:

- ◆ The (5) maples in the turf are pin oaks
- ◆ The (2) apples on the east end of the school are weeping cherries

On November 4<sup>th</sup>, 2015 fellow certified arborist, Jim Sherwood and I visited the site and took further notes. It was observed that some of the tags have already fallen off in the forest. We

*www.generaltree.com - customerservice@generaltree.com - Phone (503) 656-2656 - Toll Free 1-888-656-5401  
Fax (503) 656-3219 - 6795 SW 111th Ave. Beaverton Oregon 97008 - CCB#63604 LCB#5814*

**“Our Business is Growing Great Relationships!”**



more closely examined the forest area that will become the outdoor classroom, the perimeter trees scheduled for removal and northern boundary trees with significant defects.

On November 10<sup>th</sup> I revisited the site and checked the complete inventory that is on the blue print. All species names were corrected and passed on for an update.

### **Discussion**

The subject property is to be developed for construction of the new Sunset Primary Elementary School. Due to limited time to prepare this document the focus on the published tree inventory chart was on trees to be removed. The only significant discrepancy noted on this list is that the native cherries were misidentified as alders. On 11/11/2015 all corrections were submitted. Additional time would be needed if it is necessary to confirm all trees not impacted by construction and to number the trees that are documented & mapped surrounding the school.

### **Areas of Concern**

#### **Nine Douglas firs on perimeter**

There are (9) trees 4124, 4128, 4399, 4400, 4401, 4402, 4571, 4572 & 4574 near the southeast corner of the proposed new building that could be affected by the construction process. The building footprint appears to encroach on the critical root zone, to some degree, on all (9) trees. Root damage from construction could potentially increase the risk of tree failure to an unacceptable level. Each tree will have to be monitored individually through the process. Preservation of these firs is vital, as they are predominantly large edge trees that provide a good buffer for the forested area from the prevailing southwest winds.

#### **Five Pin Oaks**

These (5) Pin oaks are identified as maples in the turf area, are to be removed. They are a very maintenance intensive tree with poor aesthetic qualities.

#### **Perimeter Trees**

Three big leaf maples (4122, 4123, 4129) need to be removed. These trees are in decline and have considerable dead wood throughout the canopy. There are (9) cherries also scheduled for removal. They are identified as alders on the blueprints. The numbers are 4114, 4115 (2 stems), 4119 (4 stems), 4120, 4121. These trees are in very poor condition and are growing at about a 45 degree angle searching for sun light.

*www.generaltree.com - customerservice@generaltree.com - Phone (503) 656-2656 - Toll Free 1-888-656-5401  
Fax (503) 656-3219 - 6795 SW 111th Ave. Beaverton Oregon 97008 - CCB#63604 LCB#5814*

**“Our Business is Growing Great Relationships!”**



### **Holding Pond/Bio-Swale**

Two Douglas firs have to be removed due to underground boring & pipe installation. There are (7) more Douglas firs either in the proposed bio-swale or at the edge that need to be removed due to grade change. There are approximately (6) other nearby firs that will need to be protected and will need therapy to help them adjust to the altered environment.

### **Trees around Existing School**

There are (12) small planted trees that will be removed as part of the school demolition. These include (2) weeping cherries (not apples) on the east side. There are (7) 6-7" DBH styrax , (2) ornamental cherries and (1) Hinoki Cypress in front of the school. There are also (3) nuisance 27-28" DBH pin oaks in the court yard that will be damaged by demolition and will need to be removed.

### **North Property Line**

There is only (1) 26" DBH big leaf maple scheduled for removal. It is inside the fence on the northwest corner of the building. Demolition and construction will severely damage this tree. It will need to be removed.

There are (11) hazardous trees along the north property line that definitely need to be removed. Applying hazard tree risk assessment criteria, these trees all have high ratings due to size, chance of failure and the target of the children.

- ◆ (8) big leaf maples behind the covered play area - These trees have significant defects: poor taper, most have eye bolts installed in trunk, they heavily lean over play structure.

Starting at the east end:

- |              |                               |
|--------------|-------------------------------|
| ○ 13" DBH    | bolts, lean                   |
| ○ 13" DBH    | bolts, dead top               |
| ○ 13" DBH    | over hang                     |
| ○ 19" DBH    | topped, crack in trunk, decay |
| ○ 12" DBH    | dead limbs, over hang         |
| ○ 10"&15"DBH | bolts, lean and decay         |
| ○ 14" DBH    | dying, dead limbs, 1 sided    |
| ○ 21" DBH    | cavity, lean & dead limbs     |

Moving down the fence line to the west are two more large big leaf maples 24" & 26" DBH that have some serious defects. Removal should be considered. At a minimum they should be hazard pruned removing limbs and reducing end weight.

*www.generaltree.com - customerservice@generaltree.com - Phone (503) 656-2656 - Toll Free 1-888-656-5401  
Fax (503) 656-3219 - 6795 SW 111th Ave. Beaverton Oregon 97008 - CCB#63604 LCB#5814*

**"Our Business is Growing Great Relationships!"**



There are (3) Lombardy poplars, (12", 18" & 30" DBH). Two of the three trees are dying and are in very poor conditions. By nature these are a short lived tree, subject to early failure. They are an inappropriate tree for this site. The home owner is in agreement and would like these trees removed.

Further west in the back yard of an adjacent property owner there is another large Lombardy popular that is approximately 36" DBH. Even though this one is healthy, due to the nature of the tree as previously described, I recommend approaching the owner and removing this one as well.

Inside the fence is another 24" Lombardy popular that should also come out before becoming hazardous.

#### **Forest to Become Outdoor Class Room**

This is a great stand of trees consisting predominantly of Douglas fir with some big leaf maples. There are many significant firs in this stand with many trees having DBH's range from 30" to 48". Unfortunately there is a large population of invasive, non-native under story plants. These include black berry, holly, hawthorn, English laurel and worst of all English ivy. These will all need to be carefully removed avoiding damaging to native under story plants, tree roots and the soil food web.

The ivy will need to be removed so an arborist can carefully inspect the trunks of the trees being preserved. At that time a better determination can be made if there are any hazard situations that need remedied.

Initially I found (7) trees needing removal. They include:

- ◆ Non tagged damaged flowering plum
- ◆ #4597 12" DBH dead Douglas fir
- ◆ #4595 8" DBH dead big leaf maple
- ◆ #4118 12" DBH maple snag
- ◆ #4426 48" DBH snag Douglas fir
- ◆ #4572 16" dead Douglas fir
- ◆ #4427 dead cherry just south of main woods

All the trees in the natural area will need maintenance pruning to remove significant broken and dead limbs. This area is a great asset to the school and the community. Proper care should be taken in cleaning up and managing this area. There will be further details in my recommendation section.

*www.generaltree.com - customerservice@generaltree.com - Phone (503) 656-2656 - Toll Free 1-888-656-5401  
Fax (503) 656-3219 - 6795 SW 111th Ave. Beaverton Oregon 97008 - CCB#63604 LCB#5814*

**"Our Business is Growing Great Relationships!"**



## **Tree Protection**

Ideally tree roots inside the drip line of all trees should not be disturbed. In some cases with other precautions, protection zones can be pulled back to the Critical Root Zone (CRZ) which equals one foot for each inch of diameter at breast height. A 20" DBH tree would minimally need a protection zone of a 20' radius out from the trunk, all the way around the tree or grove. I would like to set all protection fences at drip or at the CRZ whichever is greater. Any deviations from these parameters must be approved by the consulting arborist.

As the improvements are constructed on site, there may be some need for review and adjustment of tree protection measures. Project arborist must approve any and all deviations.

No storage or dumping of any materials, parking of extra vehicles for construction, parking of utility or office trailers and even the pedestrian traffic of construction workers will be allowed inside fencing. Any deviation on protection outlined here or in the appendix must be approved by the consulting arborist. Please refer to appendix #1 for additional steps in protection.

## **Certification of Performance & Limiting Conditions**

I, Greg Doering certify:

- I and representatives of General Tree Service have inspected the trees and the property referred to in this report. The findings have been accurately stated to the extent of the evaluation and appraisal stated in this report.
- An ISA certified arborist has been utilized in gathering all data.
- All data was verified insofar as feasible. However General Tree Service will not be responsible for the accuracy of information provided by others.
- Legal descriptions and survey provided by Walker Macy are assumed to be correct and accurate. That information was the basis of this report.
- Unless otherwise expressed, information in report covers only items that were examined at the time of inspection. The reports reflect the condition of those items at that point in time. The inspection is limited to visual inspection of accessible items unless otherwise noted. If any other analysis or diagnostic tools were utilized, such as lab work, dissection, excavation, coring or other evaluations, extra reports would be attached.
- The analysis, opinions and conclusion were developed and prepared based on commonly accepted arboricultural practices and procedures.

*www.generaltree.com - customerservice@generaltree.com - Phone (503) 656-2656 - Toll Free 1-888-656-5401  
Fax (503) 656-3219 - 6795 SW 111th Ave. Beaverton Oregon 97008 - CCB#63604 LCB#5814*

**“Our Business is Growing Great Relationships!”**



- The report and values expressed within are based entirely on the professional opinion of the consultant and in no way contingent on any desired values, results, or findings that might be reported.
- General Tree Service's compensation is not based on any contingent results, conclusions or findings.
- Client hereby waives any right to seek or recover from General Tree Service any monetary damages, expenses or losses, including consequential or incidental damages arising out of or from acts or omissions of General Tree Service. The limitation will not apply to the extent of the client's damages that were caused by General Tree's reckless or willful misconduct in performance or nonperformance of services.
- Our role as consultants is to make recommendations; inaction of those receiving the report is not our responsibility.
- I further certify that I am a member of the International Society of Arboriculture and am both a certified arborist and tree risk assessment qualified.

## **Conclusion**

By following the recommended tree protection and maintenance procedures the remaining trees should be far enough away from the construction zones to survive and adapt to site changes. Tree protection zones must be established prior to all construction on site. Any deviation from the protection plan must be reviewed and approved by the project arborist. Protecting remaining trees needs to be a priority on the project.

## **Recommendations**

1. Remove all (43) trees that are designated on the blue print.( Note some of the smaller trees are grouped together on the blue print.)
2. Remove (11) hazardous trees on the north property line
3. Seek removal permits for (4) additional trees on north property line
4. Remove (7) trees in the forest and others if determined hazardous once ivy is removed.
5. Install tree protection fencing at drip line of all trees or groves to be preserved at the construction site (an addition of 2" chips in root zones will reduce stress to roots)
6. Pay careful attention to construction trauma near (9) Douglas firs 4124, 4128, 4399, 4400, 4401, 4402, 4571, 4572 & 4574. These are dominant trees that will not tolerate significant impact to their roots. Reducing the distance of the tree protection barriers can lead to significant health issues or complete tree failure. These trees will definitely need some level of therapy if preserved.

*www.generaltree.com - customerservice@generaltree.com - Phone (503) 656-2656 - Toll Free 1-888-656-5401  
Fax (503) 656-3219 - 6795 SW 111th Ave. Beaverton Oregon 97008 - CCB#63604 LCB#5814*

**"Our Business is Growing Great Relationships!"**



7. Remove all non-native, invasive understory plants in the forest. This includes black berry, English laurel, hawthorn, holly, and English Ivy. Removal will open up the forest to be used for an outdoor class room and reduce security risks. The ivy needs to be removed from the trees so they can be examined closer to search for any flaws or concerns. No heavy equipment to be allowed in the area. All removals should be accomplished using hand equipment. Disturbing of the soil food web, roots and favorable small native trees and shrubs should be avoided. I would recommend cleaning up early in the project to provide adequate time before landscaping. Follow up spot herbicide treatments or additional hand removal will be needed to prevent reestablishment of undesirable plant material.
8. Native trees in forest will need hazard reduction pruning prior to planting and opening back up. Crown cleaning of dead, diseased or hazardous limbs 2" and greater should be scheduled along with removal of any remaining ivy in the trees.
9. Trees should be monitored by consulting arborist and receive deep root fertilization or other therapies if needed. Insect or disease treatments would be recommended if damage thresholds are reached.
10. If drought conditions exist or there is possible root damage, supplemental watering may be advised if conditions dictate.
11. Planting and landscaping in the forest should be carefully planned. Turf or succulent plants requiring large amount of water should be avoided. The focus should be with native shade loving understory plants. Mulch, bark, compost, logs, rock and natural materials should be utilized. If irrigation is required for establishing plant material it should be drip or low volume in nature.

Please call if you have questions or concerns regarding this report.

Sincerely,

A handwritten signature in black ink that reads "Greg Doering". The signature is fluid and cursive, with the first letters of each word being capitalized and prominent.

Greg Doering  
ISA Certified Arborist PN-0676A  
ISA Tree Risk Assessment Qualified  
503-705-2878  
g.doering@generaltree.com

Enclosures:

*www.generaltree.com - customerservice@generaltree.com - Phone (503) 656-2656 - Toll Free 1-888-656-5401  
Fax (503) 656-3219 - 6795 SW 111th Ave. Beaverton Oregon 97008 - CCB#63604 LCB#5814*

**"Our Business is Growing Great Relationships!"**





## Appendix # 1

### Tree Protection Steps

It is critical that the following steps be taken to ensure that the trees that are to be retained are protected.

#### **Prior to Construction**

##### **I. Notification**

- a. All contractors will be notified of the tree protection procedures. For successful tree protection on the construction site, all contractors must know and understand the goals of tree protection. One mistake can destroy the future health of a tree.
  1. Hold a Tree Protection meeting with all contractors to fully explain goals of tree protection
  2. Have all sub contractors sign a 'memoranda of understanding' outlining the goals and procedures of the tree protection. The document includes a penalty for violating the plan. Penalty is equal to the appraised value of tree or trees within the violated tree protection zone. The value will be determined based the Trunk Formula Method outlined by the Council of Tree & Landscape Appraisers current edition of the **Guide for Plant Appraisal**. The penalty to be paid by the property owner.

##### **II. Fencing**

- a. Fencing must be installed around each tree or grove of trees to be retained
- b. Installation will be prior to grown breaking of the project.
- c. Fencing to be placed at the edge of the root protection zone established. These zones are established by the project arborist. Unless other wise noted, this should be at or beyond the drip line.
- d. Fencing will be 6' foot high steel fence secured on concrete blocks or with 8' metal posts. The fence should be secure so it can not readily be moved by contractors or damaged by weather or equipment.
- e. Fencing is to remain in place as determined by the consulting arborist and remain in place until completion of the project. It can not be removed without written permission from the project arborist.

##### **III. Signage**

- a. All tree protection fencing should have signage as follows so all contractors understand the purpose of the fencing.
- b. The signs should be laminated to withstand weather
- c. Signage should be visible from all sides of the protection area. Signs should be no further than 75' apart.

*www.generaltree.com - customerservice@generaltree.com - Phone (503) 656-2656 - Toll Free 1-888-656-5401  
Fax (503) 656-3219 - 6795 SW 111th Ave. Beaverton Oregon 97008 - CCB#63604 LCB#5814*

**"Our Business is Growing Great Relationships!"**



## TREE PROTECTION ZONE

### DO NOT REMOVE OR ADJUST THE APPROVED LOCATION OF THIS TREE PROTECTION FENCING.

**Note: Moving these fences is a civil violation of West Linn Codes**

Please contact the project arborist or owner if alterations to the approved location of the tree protection fencing are necessary.

General Tree Service  
503-656-2656

### During Construction

- I. Protection Guidelines Within the Root Protection Zone
  - a. No traffic allowed within the root protection zone including vehicle or heavy equipment. Foot traffic should be minimized
  - b. No parking or storage of vehicles or equipment in the root protection zone.
  - c. No storage of materials, soil or waste including fuel, oil, paint, cleaners or thinners.
  - d. No activities that may cause soil compaction are allowed in the root protection zone.
- II. The trees shall be protected from cutting, debarking or breaking of branches.
- III. Any roots that are to be cut from existing trees that are to be retained, the project consulting arborist shall be notified to evaluate and oversee the proper cutting of roots with sharp cutting tools. Cut roots are to be immediately covered with soil or mulch to prevent them from drying out.
  - a. No grade change should be allowed within the root protection zone.
  - b. Any necessary deviation of the root protection zone shall be cleared by the project consulting arborist or project owner.
  - c. Provide water to trees during the summer months for tree(s) that will have had root system(s) cut back. Such trees will need supplemental water to overcome the loss of the ability to absorb necessary moisture during the summer months.
  - d. Any necessary passage of utilities through the root protection zone shall be by means of tunneling under roots by hand digging or boring under the observation of the project consulting arborist.

### After Construction

- I. Carefully landscape in the area of the tree. Do not allow trenching within the root protection zone. Carefully plant new plants within the root protection zone. Avoid cutting the roots of the existing trees.
- II. Do not plan for irrigation within the root protection zone of existing trees unless it is drip irrigation for a specific planting or cleared in writing by the project consulting arborist.
- III. Provide for adequate drainage of the location around the retained trees.
- IV. Pruning of the trees should be completed as one of the last steps of the landscaping process before the final placement of trees, shrubs, ground covers, mulch or turf.

Provide for inspection and treatment of insect and disease populations that are capable of damaging the retained trees and plants. Trees that are retained may need to be fertilized as called for by the project consulting arborist after final inspection.

*www.generaltree.com - customerservice@generaltree.com - Phone (503) 656-2656 - Toll Free 1-888-656-5401  
Fax (503) 656-3219 - 6795 SW 111th Ave. Beaverton Oregon 97008 - CCB#63604 LCB#5814*

**“Our Business is Growing Great Relationships!”**

### Appendix # 2

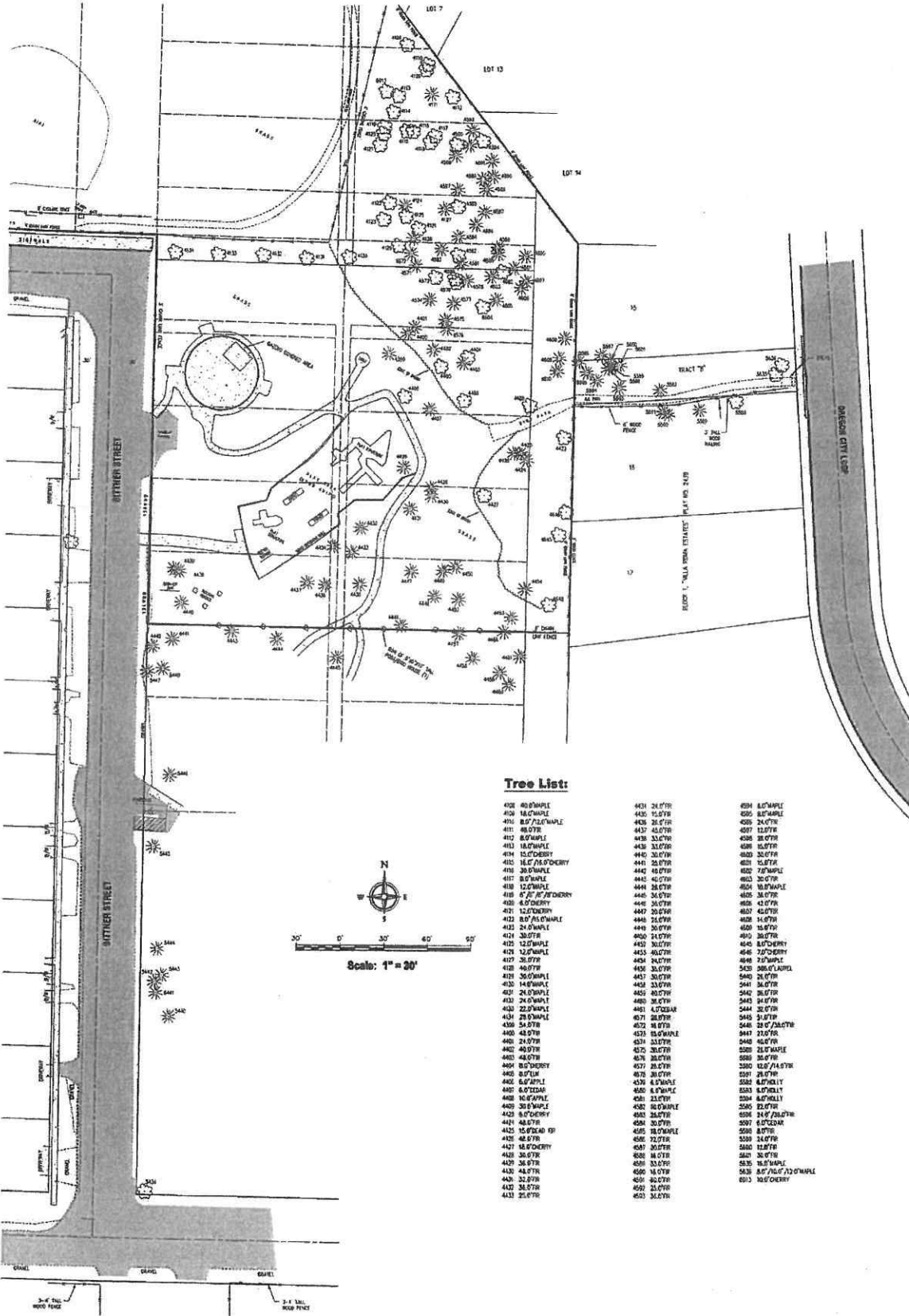

**Tree List:**

4102 40' MAPLE	4431 24' PFR	4858 45' MAPLE
4103 18' MAPLE	4432 15' PFR	4859 45' MAPLE
4110 8' PFR	4433 24' PFR	4865 24' PFR
4111 40' PFR	4437 45' PFR	4877 12' PFR
4112 8' PFR	4438 12' PFR	4886 28' PFR
4113 18' MAPLE	4439 32' PFR	4896 15' PFR
4114 15' DOBERRY	4440 32' PFR	4923 32' PFR
4115 14' PFR DOBERRY	4441 28' PFR	4924 15' PFR
4116 30' MAPLE	4442 40' PFR	4932 7' MAPLE
4117 30' MAPLE	4443 40' PFR	4933 30' PFR
4118 12' MAPLE	4444 24' PFR	4934 18' MAPLE
4119 8' PFR DOBERRY	4446 36' PFR	4935 36' PFR
4120 4' DOBERRY	4448 36' PFR	4936 42' PFR
4121 12' DOBERRY	4447 20' PFR	4937 42' PFR
4122 18' MAPLE	4448 15' PFR	4938 14' PFR
4123 24' MAPLE	4449 30' PFR	4939 18' PFR
4124 30' PFR	4950 24' PFR	4940 36' PFR
4125 12' MAPLE	4951 30' PFR	4943 17' DOBERRY
4126 12' MAPLE	4952 30' PFR	4946 17' DOBERRY
4127 30' PFR	4953 30' PFR	4948 7' MAPLE
4128 40' PFR	4954 34' PFR	5429 30' OF CLOVEL
4129 30' MAPLE	4955 30' PFR	5440 28' PFR
4130 14' MAPLE	4956 30' PFR	5441 36' PFR
4131 24' MAPLE	4957 40' PFR	5442 36' PFR
4132 24' MAPLE	4960 24' PFR	5443 34' PFR
4134 28' MAPLE	4961 40' CEDAR	5444 32' PFR
4136 54' PFR	4971 36' PFR	5445 32' PFR
4140 45' PFR	4972 34' PFR	5446 28' OF CLOVEL
4148 24' PFR	4973 15' MAPLE	5447 22' PFR
4149 40' PFR	4974 34' PFR	5448 42' PFR
4150 40' PFR	4975 36' PFR	5528 28' MAPLE
4151 40' PFR	4976 30' PFR	5529 36' PFR
4152 40' PFR	4977 24' PFR	5530 12' OF CLOVEL
4153 8' PFR	4978 30' PFR	5531 28' PFR
4154 8' MAPLE	4979 4' MAPLE	5532 45' HOLLY
4155 6' PFR	4980 4' PFR	5533 45' HOLLY
4156 16' MAPLE	4981 23' PFR	5534 45' HOLLY
4157 30' MAPLE	4982 30' MAPLE	5535 22' PFR
4158 8' DOBERRY	4983 36' PFR	5536 24' OF CLOVEL
4159 44' PFR	4984 30' PFR	5537 6' CEDAR
4160 15' OF CLOVEL	4985 15' MAPLE	5538 27' PFR
4161 48' PFR	4986 32' PFR	5539 14' PFR
4162 36' PFR	4987 30' PFR	5540 12' PFR
4163 36' PFR	4988 14' PFR	5641 36' PFR
4164 44' PFR	4989 36' PFR	5635 18' MAPLE
4165 34' PFR	4990 18' PFR	5638 8' OF CLOVEL
4167 34' PFR	4991 34' PFR	6013 18' DOBERRY
4168 25' PFR	4992 36' PFR	

## Tree List:

4108	40.0"MAPLE	4434	24.0"FR	4594	6.0"MAPLE
4109	18.0"MAPLE	4435	15.0"FR	4595	8.0"MAPLE
4110	8.0"/12.0"MAPLE	4436	26.0"FR	4596	24.0"FR
4111	48.0"FR	4437	45.0"FR	4597	12.0"FR
4112	8.0"MAPLE	4438	33.0"FR	4598	28.0"FR
4113	18.0"MAPLE	4439	33.0"FR	4599	15.0"FR
4114	15.0"CHERRY	4440	30.0"FR	4600	30.0"FR
4115	16.0"/16.0"CHERRY	4441	25.0"FR	4601	15.0"FR
4116	30.0"MAPLE	4442	40.0"FR	4602	7.0"MAPLE
4117	8.0"MAPLE	4443	40.0"FR	4603	30.0"FR
4118	12.0"MAPLE	4444	28.0"FR	4604	10.0"MAPLE
4119	6"/6"/6"/8"CHERRY	4445	36.0"FR	4605	36.0"FR
4120	6.0"CHERRY	4446	36.0"FR	4606	42.0"FR
4121	12.0"CHERRY	4447	20.0"FR	4607	40.0"FR
4122	8.0"/15.0"MAPLE	4448	26.0"FR	4608	14.0"FR
4123	24.0"MAPLE	4449	30.0"FR	4609	15.0"FR
4124	30.0"FR	4450	24.0"FR	4610	30.0"FR
4125	12.0"MAPLE	4452	30.0"FR	4645	8.0"CHERRY
4126	12.0"MAPLE	4453	40.0"FR	4646	7.0"CHERRY
4127	36.0"FR	4454	24.0"FR	4648	7.0"MAPLE
4128	40.0"FR	4456	35.0"FR	5439	306.0"LAUREL
4129	30.0"MAPLE	4457	30.0"FR	5440	26.0"FR
4130	14.0"MAPLE	4458	33.0"FR	5441	36.0"FR
4131	24.0"MAPLE	4459	40.0"FR	5442	36.0"FR
4132	24.0"MAPLE	4460	36.0"FR	5443	24.0"FR
4133	22.0"MAPLE	4461	4.0"CEDAR	5444	32.0"FR
4134	28.0"MAPLE	4571	28.0"FR	5445	51.0"FR
4389	54.0"FR	4572	16.0"FR	5446	28.0"/38.0"FR
4400	48.0"FR	4573	15.0"MAPLE	5447	27.0"FR
4401	24.0"FR	4574	33.0"FR	5448	40.0"FR
4402	40.0"FR	4575	30.0"FR	5588	28.0"MAPLE
4403	48.0"FR	4576	20.0"FR	5589	30.0"FR
4404	8.0"CHERRY	4577	26.0"FR	5590	12.0"/14.0"FR
4405	8.0"ELM	4578	30.0"FR	5591	26.0"FR
4406	6.0"APPLE	4579	6.0"MAPLE	5592	6.0"HOLLY
4407	6.0"CEDAR	4580	6.0"MAPLE	5593	6.0"HOLLY
4408	10.0"APPLE	4581	23.0"FR	5594	6.0"HOLLY
4409	30.0"MAPLE	4582	10.0"MAPLE	5595	22.0"FR
4423	6.0"CHERRY	4583	25.0"FR	5596	24.0"/38.0"FR
4424	48.0"FR	4584	30.0"FR	5597	6.0"CEDAR
4425	15.0"DEAD FR	4585	18.0"MAPLE	5598	8.0"FR
4426	48.0"FR	4586	12.0"FR	5599	24.0"FR
4427	18.0"CHERRY	4587	30.0"FR	5600	12.0"FR
4428	30.0"FR	4588	16.0"FR	5601	30.0"FR
4429	36.0"FR	4589	33.0"FR	5635	16.0"MAPLE
4430	48.0"FR	4590	16.0"FR	5636	8.0"/10.0"/12.0"MAPLE
4431	32.0"FR	4591	60.0"FR	6013	10.0"CHERRY
4432	36.0"FR	4592	25.0"FR		
4433	25.0"FR	4593	36.0"FR		

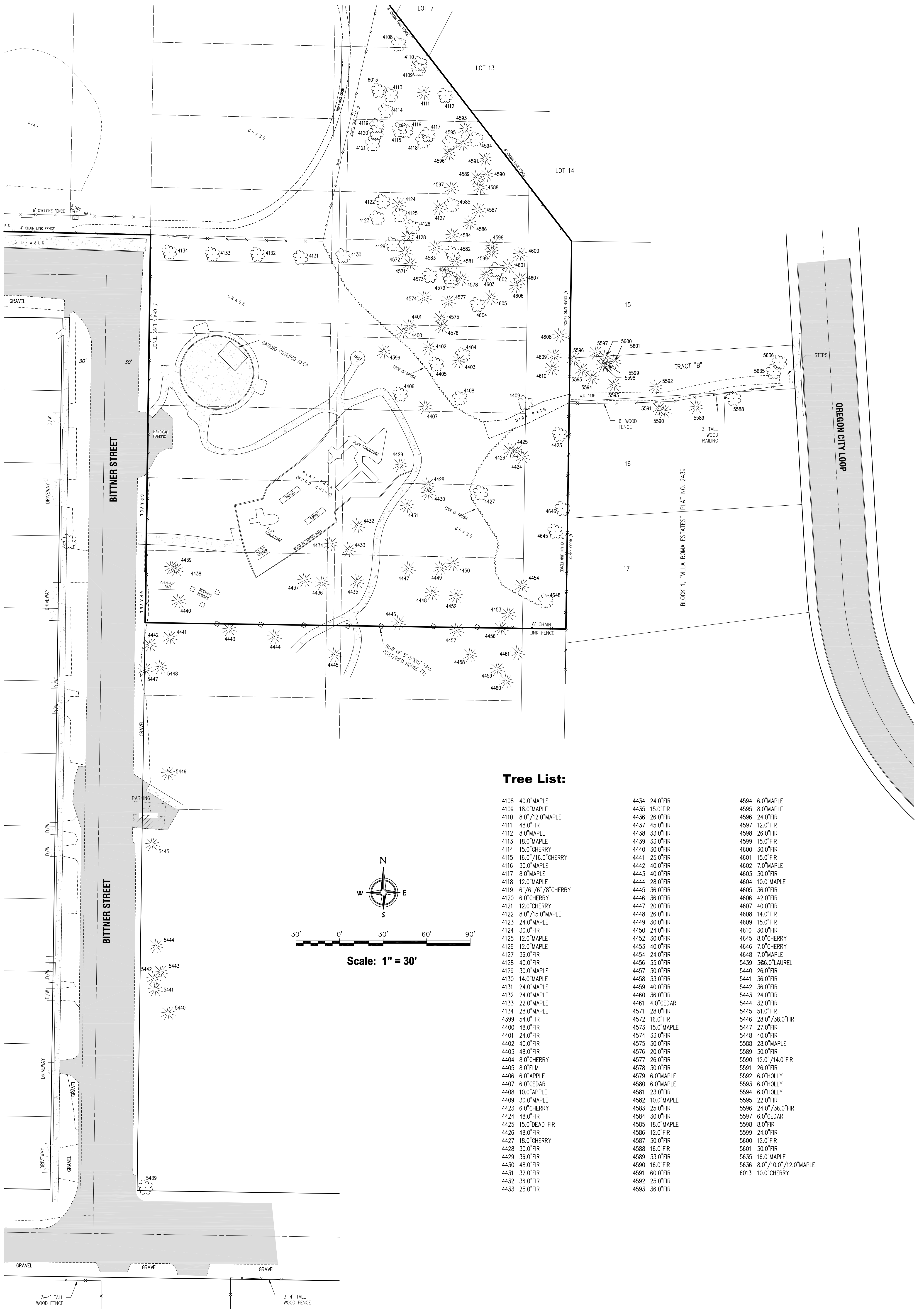

**Tree List:**

4108 40.0"MAPLE	4434 24.0" FIR	4594 6.0"MAPLE
4109 18.0"MAPLE	4435 15.0" FIR	4595 8.0"MAPLE
4110 8.0"/12.0"MAPLE	4436 26.0" FIR	4596 24.0" FIR
4111 48.0" FIR	4437 45.0" FIR	4597 12.0" FIR
4112 8.0"MAPLE	4438 33.0" FIR	4598 26.0" FIR
4113 18.0"MAPLE	4439 33.0" FIR	4599 15.0" FIR
4114 15.0"CHERRY	4440 30.0" FIR	4600 30.0" FIR
4115 16.0"/16.0"CHERRY	4441 25.0" FIR	4601 15.0" FIR
4116 30.0"MAPLE	4442 40.0" FIR	4602 7.0"MAPLE
4117 8.0"MAPLE	4443 40.0" FIR	4603 30.0" FIR
4118 12.0"MAPLE	4444 28.0" FIR	4604 10.0"MAPLE
4119 6"/6"/6"/8"CHERRY	4445 36.0" FIR	4605 36.0" FIR
4120 6.0"CHERRY	4446 36.0" FIR	4606 42.0" FIR
4121 12.0"CHERRY	4447 20.0" FIR	4607 40.0" FIR
4122 8.0"/15.0"MAPLE	4448 26.0" FIR	4608 14.0" FIR
4123 24.0"MAPLE	4449 30.0" FIR	4609 15.0" FIR
4124 30.0" FIR	4450 24.0" FIR	4610 30.0" FIR
4125 12.0"MAPLE	4452 30.0" FIR	4615 8.0"CHERRY
4126 12.0"MAPLE	4453 40.0" FIR	4646 7.0"CHERRY
4127 36.0" FIR	4454 24.0" FIR	4648 7.0"MAPLE
4128 40.0" FIR	4455 35.0" FIR	5439 306.0"LAUREL
4129 30.0"MAPLE	4457 30.0" FIR	5440 26.0" FIR
4130 14.0"MAPLE	4458 33.0" FIR	5441 36.0" FIR
4131 24.0"MAPLE	4459 40.0" FIR	5442 36.0" FIR
4132 24.0"MAPLE	4460 36.0" FIR	5443 24.0" FIR
4133 22.0"MAPLE	4461 4.0"CEDAR	5444 32.0" FIR
4134 28.0"MAPLE	4471 28.0" FIR	5445 51.0" FIR
4399 54.0" FIR	4572 16.0" FIR	5446 28.0"/38.0" FIR
4400 48.0" FIR	4573 15.0"MAPLE	5447 27.0" FIR
4401 24.0" FIR	4574 33.0" FIR	5448 40.0" FIR
4402 40.0" FIR	4575 30.0" FIR	5588 28.0"MAPLE
4403 48.0" FIR	4576 20.0" FIR	5589 30.0" FIR
4404 8.0"CHERRY	4577 26.0" FIR	5590 12.0"/14.0" FIR
4405 8.0"ELM	4578 30.0" FIR	5591 26.0" FIR
4406 6.0"APPLE	4579 6.0"MAPLE	5592 6.0"HOLLY
4407 6.0"CEDAR	4580 6.0"MAPLE	5593 6.0"HOLLY
4408 10.0"APPLE	4581 23.0" FIR	5594 6.0"HOLLY
4409 30.0"MAPLE	4582 10.0"MAPLE	5595 22.0" FIR
4423 6.0"CHERRY	4583 25.0" FIR	5596 24.0"/36.0" FIR
4424 48.0" FIR	4584 30.0" FIR	5597 6.0"CEDAR
4425 15.0"DEAD FIR	4585 18.0"MAPLE	5598 8.0" FIR
4426 48.0" FIR	4586 12.0" FIR	5599 24.0" FIR
4427 18.0"CHERRY	4587 30.0" FIR	5600 12.0" FIR
4428 30.0" FIR	4588 16.0" FIR	5601 30.0" FIR
4429 36.0" FIR	4589 33.0" FIR	5635 16.0"MAPLE
4430 48.0" FIR	4590 16.0" FIR	5636 8.0"/10.0"/12.0"MAPLE
4431 32.0" FIR	4591 60.0" FIR	6013 10.0"CHERRY
4432 36.0" FIR	4592 25.0" FIR	
4433 25.0" FIR	4593 36.0" FIR	

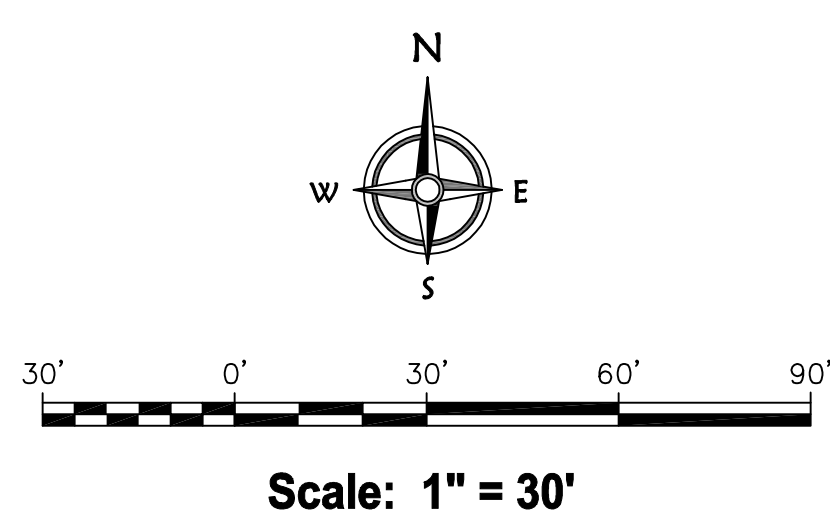

**EXHIBIT E**  
**Noise Study**

November 13, 2015

To: Bill Conboy  
Dull Olson Weekes Architects  
From: Dennis Noson, PhD  
Re: *Anticipated Site Noise Conditions*  
Sunset Primary School, West Linn, OR

BRC Acoustics has prepared an acoustical analysis of noise sources, and sound propagation conditions at the school site, for a new Sunset Primary School structure, to be located just to the east, and immediately adjacent to the existing school. In the analysis which follows, the noise reduction provisions of the school design will comply with noise *limits* of the Noise Regulations of the City of West Linn. Note that an evaluation of *increases* to ambient (existing) noise (Oregon DEQ, OAR 340-035-0035, par. 1(b)) are not applicable in the case of a reuse at an existing school site.

Noise from school noise sources, as received at neighboring properties, are subject to limits imposed by Chapter 55 of the City of West Linn’s Community Development Code, which, in turn, is based upon the Oregon Administrative Regulations (OAR 340-35-035) limiting noise from industrial and commercial noise sources. For the purposes of this noise analysis, the school site is considered a commercial noise source, rather than a residential noise source, which would have a different set of noise limits.

The Noise limits are as follows (City of West Linn, Chapter 55):

**Existing Industrial and Commercial Noise Source Standards**

**Allowable Statistical Noise Levels in Any One Hour**

**7am – 10 pm**

L<sub>50</sub> – 55 dBA

L<sub>10</sub> – 60 dBA

L<sub>1</sub> – 75dBA

**10 pm – 7am**

L<sub>50</sub> – 50 dBA

L<sub>10</sub> – 55 dBA

L<sub>1</sub> – 60 dBA

Noise from the school site will vary with time, within a given hour, and over the school day. The City of West Linn noise limits are evaluated by determining on a statistical basis. The noise limit is relative to the percent of the time in any school day hour the sound level is higher than the

noise limits given in the table (above). Allowable sound levels therefore are dependent upon whether the noise is steady during the hour, versus varying noise.

In the case of varying noise sources, the noise evaluation determines how often in a given hour a noise source will affect the receiver (typically evaluated at the nearest residence). Based upon the table of allowable noise, sources of variable noise are acceptable for 50% of full time if equal to or less than 55 dBA ( $L_{50}$  sound statistic); if present no more than 10% of the time, sound sources are allowed to be higher, at 60 dBA. Noise up 75 dBA is allowed if the noise exceeding this level occurs less than 1% of the time.

Refer to Appendix A for definitions and descriptions of sound measurements in decibels, and characteristics of sound loudness and sound sources.

### Site Noise Sources

Noise from sources affecting the neighborhood include the following:

- Vehicle noise from school transit buses, parent vehicles (for drop-off), and vehicles entering and leaving staff parking
- Play area sounds from sports and free play activities
- Equipment and mechanical system noise, including the following:
  - Trash compactor noise
  - Pad mounted outdoor power transformer
  - Testing of engine generator (providing emergency power)
  - Mechanical system: rooftop fans and air handlers

Noise sources as listed above are shown in the school site plan, attached.

Note: Chiller equipment providing cooling to the rooftop systems will *not* take the form of a stand-alone air cooled chiller, sitting on ground level. Chillers are often a source of noise complaint by residents adjacent to schools. Cooling will, instead, be provided internally by compressors in each of the rooftop air handlers.

### Traffic & Vehicle Noise

Noise levels from vehicle traffic will remain unchanged. The number of vehicles accessing the school site (vehicles per hour) and their operation speeds will be the same as current conditions. Parking areas will be relocated relative to the current school parking area. School bus operations will take place in the same manner as the current bus use of the site. Since the primary source of vehicle noise is the arrival and departure of school buses, any change in traffic noise exposure during the school day at neighboring residences will be insignificant (i. e. less than 1 or 2 dB difference).

### Play Area Noise

The siting of new play areas will be essentially at the same locations as existing play areas, relative to the neighborhood. The ballfield will shift approximately 250 feet west, with no



significant change in sound path exposure to the near-by residences. No change in sound level from ballfield activity is anticipated.

### Trash Compactor Noise

The school will be utilizing a trash compactor to reduce the size of waste storage, rather than handling school waste and school recycling by means of truck transfer from storage containers. The use of a compactor will also reduce the number of visits required by waste and recycling services.

Noise ratings for the compactor, as provided by the manufacturer, are as follows:

on-axis	75 to 77 dBA
left & right	75 to 78
panel end	76 to 77

All distances are at 5 feet from the actuator power source (data provided by Marathon Equipment).

Predictions of operational noise at residences nearest to the compactor were carried out using the worst case of on-axis noise at 78 dBA as the source level. Prediction results:

South @ 135 ft	39 dBA	noise is obstructed by service area wall
SW @ 210 ft	43 dBA	in line of sight

Refer to the noise source site plan, with sound paths and distances shown (attached).

Results of Analysis: Maximum allowable sound levels at the nearest residence will not be exceeded, neither during normal operating hours (7:00am – 10:00pm) nor during nighttime hours when the City noise limit is stricter (50 dBA).

### PGE Power Transformer Noise

The largest outdoor electric power transformers provided by the electric utility (PGE) are rated at 60 dBA. Which size and model to be installed by PGE is not known, but is expected to be smaller than 1500 kVA. A large transformer of this size is slightly louder than the smaller utility sizing options, and is sound rated at 60 dB, which then can be considered as the likely upper noise level for the transformer. At this sound level, the transformer should be located at least 75 feet from any home to assure sound levels are below the nighttime limit of 50 dBA.

Results of Analysis: In the current design, the transformer is located 135 feet north of the nearest residence on Park Street, which is a compliant condition at this and all other more distant residences, for a 60 dB rated transformer.

### Emergency Power Engine Generator

The Cummins model 60DSFAD planned for the school is sound rated by the manufacturer, when provided in an acoustical-upgraded weather enclosure, as follows:

average @ 7 m.	79 dBA
----------------	--------

Engine noise sources are primarily the muffler exhaust, engine radiator fan, combustion air inlet, and engine casing (cylinders & crankcase). If tested for the usual engine exercise time of 30 minutes, the generator *must not exceed 55 dBA* at the nearest residences.

The new generator will be located in service yard enclosure at the west side of the school building. The generator will likely be tested monthly, but no more often than weekly.

Generator sound paths will be obstructed on the north, east, and south sides by the building structure. The west side will be closed with a louvered gate and fence. Given this location, and the sound attenuating package for the generator, the expected noise levels at the nearest residences are as follows:

West @ 425 ft (nearest residence)	49	partially shielded by louvered gate
SW @ 210 ft	53	nearest receiver via louvered gate
South @ 135 ft (obscured by wall)	45	fully obstructed by service yard wall

Based upon BRC measurements of engine generators, the lowest sound levels are emitted by the engine enclosure from the long sides, with higher sound levels on the air inlet and radiator fan ends of the generator (the narrow width sides). Noise on the quieter sides reduces the radiated sound below the average reported by the manufacturer (79 dBA).

Results of Analysis: Noise of engine testing is expected to meet the 55 dBA limit (for 30 minute duration of engine operation). To do so, the generator enclosure as specified will include a manufacturer's F172 "Quiet Site II First Stage" silencing package. The package includes a higher sound-attenuating muffler, air inlet and discharge silencers, and heavier casing of the enclosure.

### **Mechanical Systems**

Mechanical system equipment noise ratings were determined based upon the mechanical engineer's Schematic Design for the school, including heating/ventilating/air-conditioning equipment (HVAC) at rooftop locations and exhaust fans for the kitchen and restrooms:

Noise performance, as supplied by HVAC manufacturers, is provided in Appendix B, and is based upon the current sizing and type of equipment selected by the mechanical engineer.

Tabulated noise ratings for the mechanical equipment (in Appendix B) are given in *sound power* values, which can be converted to *sound pressure* levels, in dBA, at a given (or known) measurement distance. Predicted sound levels (sound pressure) are reduced (weakened) as (a) receiver distances increase, (b) line of sight to the equipment is obstructed by parapet walls, or equipment "wells" at roof top locations, and as (c) landform topography and landscape plant cover intervenes in the source to receiver sound path (minor noise reduction effect for plant cover).

Given these variables, the preliminary noise levels as received at the nearest residences, to the south and west, across Park Street, are as follows:

25,000 cfm air handlers	48 dBA	including sound barrier (parapet or screen wall)
10,000 cfm air handlers	42 dBA	" " "

Kitchen exhaust fans	41 dBA	“	“	“	(well, or screen wall)
Gym HRU	43 dBA	without	sound	barrier	
Building exhaust fans	43 dBA	without	sound	barrier	

All rooftop mechanical equipment, when operated simultaneously, will produce a total noise level summed by logarithm analysis (see Appendix A, at paragraph “Decibels”).

The highest possible noise level, combining rooftop air handlers and exhaust fan noise sources, is 51 dBA (nearest air handler at 145 feet). The actual sound level will be significantly lower, since each of the equipment noise sources is farther from the residences than the nearest (at 145 feet). See the Site Plan, attached.

Results of Analysis: Mechanical equipment operates steadily during the school hours, and complies with the City’s noise limit of 55 dBA for daytime hours. At night, most mechanical system equipment will be shut down, and will be maintaining lower temperatures. Estimated noise levels for the night condition are 44 to 46 dBA (rooftop air handlers operating intermittently, exhaust fans off).

#### *Attachments*

---

**Site Plan:** Noise source locations

**Appendix A:** Acoustical Terms and Definitions

**Appendix B:** HVAC Equipment—noise ratings

**Noise Sources:**

- A: PGE transformer
- B: Trash compactor
- C: Emergency generator
- D: Mechanical rooftop equipment
- D2: Heat recovery unit

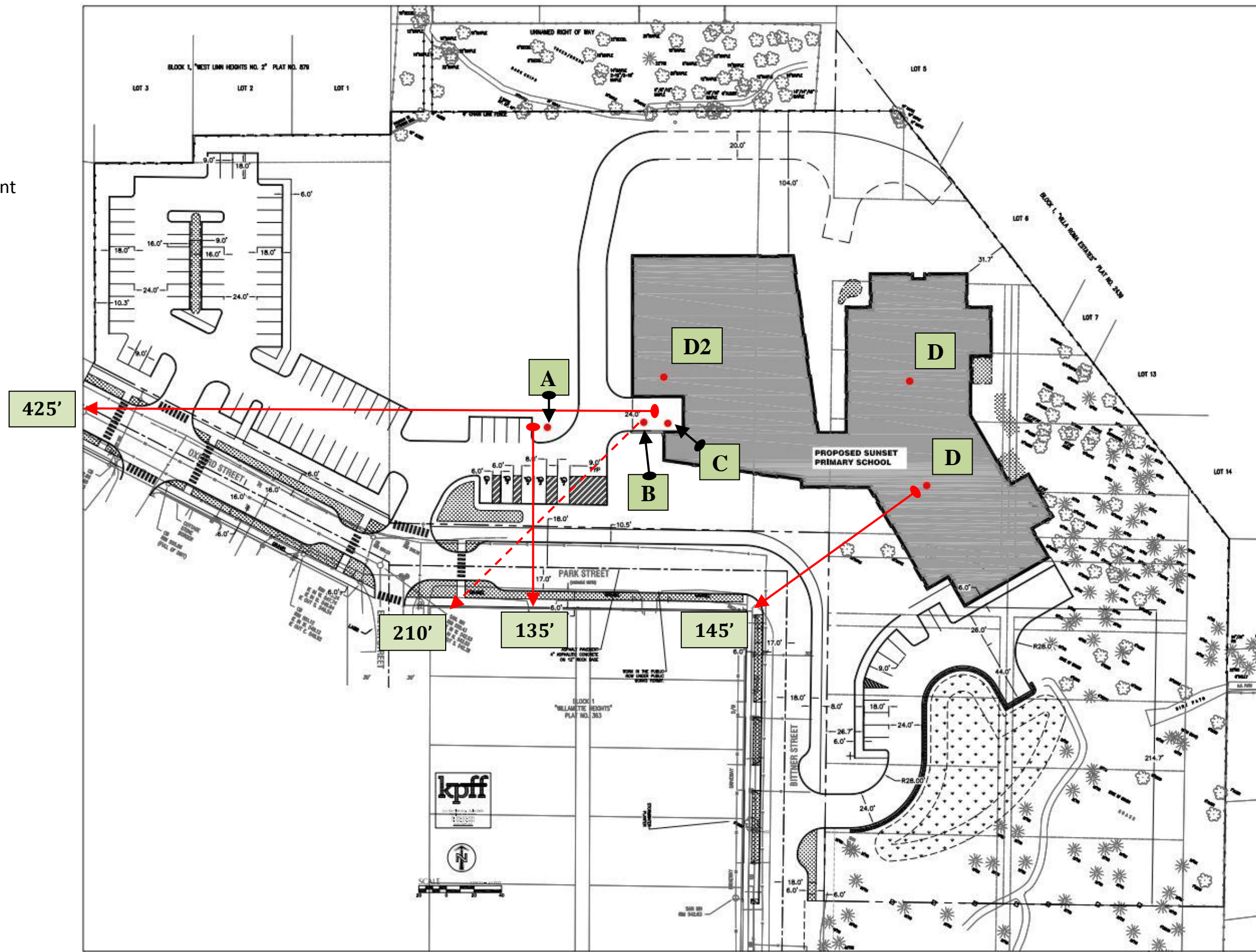

## Appendix A: Acoustical Terms and Definitions

### *Summary -- Decibels and Loudness Differences*

Noise levels referred to in noise ordinances and noise measurements are expressed in decibels “dB,” which are, in turn, weighted to conform with the normal sensitivity of the human ear. Measurement when weighted, the standard practice in acoustics, are referred to as A-weighted sound level, abbreviated “dBA.”

A noise level at 60 dBA, for example, is about equally as loud as a normal conversation, but nevertheless strongly affects talking and listening, and is considered very annoying in otherwise quiet outdoor environments. A major highway at a distance of 100 feet measures about 75 to 80 dBA, nearly drowning out conversation.

Noise levels which differ by less than 3 dB are difficult to distinguish in loudness. A 5 dB increase is significantly louder, and a 10 dB difference when comparing two continuous noise sources is twice as loud.

### *Decibels*

The decibel scale is universally applied in the measurement of sound pressure levels and is abbreviated as “dB.” The decibel is a logarithmic function of the acoustic energy, a measurement scale for sound which is not directly proportional to the loudness of a noise or sound source. With a *linear* measuring scale, a sound source rated at 40 would be measured at 80 for two equally-loud sources. Because of the logarithmic scale, however, sound levels cannot be added using simple arithmetic. Nor does the ear hear two equal sounds as twice as loud. As a result, using decibels, two equal sound sources at 40 dB add together to a 43 dB combined sound level, using the 3 dB rule for each doubling of acoustical energy. The same result applies to A-weighted decibel sound levels.

### *Typical Decibel Sound Levels*

Commonly-occurring distant noise sources have levels ranging from 30 dBA in quiet rural areas, to about 45 dBA in suburban areas, on up to 85 to 90 dBA when adjacent to power saws, chain saws, or un-muffled lawn mower engines. Urban street traffic noise ranges from 65 to 75 dBA, and is very unsteady in character, due to passage of louder vehicles, which can increase noise levels (briefly) to 80 dBA or more. At the middle of the range of sound levels is speech: conversational speech levels vary with time and with vocal emphasis, typically varying from 50 to 65 dBA. A final example: At locations across the street from active construction sites, noise levels can, at times, exceed 85 to 90 dBA, although average construction noise is normally 10 to 20 dB less.

### *A-weighted Decibels*

Noise levels are usually measured in A-weighted decibels, abbreviated “dBA.” Noise measurements indicated with the abbreviation “dB” are not A-weighted, unless indicated otherwise. Application of A-weighting is the standard adjustment method for sound measurements and is used to compensate for the varying sensitivity of human hearing to high

versus low pitched sounds (drums versus piccolos). The ear's weighting, and the sound level meter's, is applied to each of many sound components comprising the sound spectrum (see the definition of *sound spectrum*).

When summed together, the weighted spectrum components comprise the total or overall sound level. The sound level weighting mimics diminished human sensitivity to low frequency components of noise sources, sounds characterized as rumbling or humming in nature. For example, the human ear evaluates an 80 dB shrill whistle as quite loud, while an electrical system hum at the same measured 80 dB level (unweighted) is perceived to be less than one-third as loud.

### *Loudness*

The loudness of sound is not linear in response to changes in decibel levels. That is, a 20% increase in decibel level is *not* 20% louder. A sound or noise at 50 dBA is 100% louder (twice as loud) when increasing to 60 dBA, which arithmetically is only 20% larger in value (60 dBA is 20% more than 50 dBA as measured on the sound meter). Since an increase of at least 10 dB is needed to cause an approximate doubling of judged loudness, then conversely a 10 dB *decrease* is perceived as half as loud. Going from 50 to 60 dBA is judged to be twice as loud, and therefore a 70 dBA noise level is *four* times louder than a 50 dBA steady noise source (doubling twice).

The smallest distinctly noticeable increase in sound level is approximately 3 dB, which represents a doubling of the sound wave *energy*, but does *not* correspond to a doubling of the perceived change in loudness.

### *Sound Spectrum (in dB) and Sound Wave Frequency (Hz)*

Sound or noise consists of a mix of pressure waves traveling in air. Each component of the sound has its own rate of oscillation, the more rapid the oscillation the higher the *frequency*. Sound wave frequency is roughly equivalent to pitch in music. Sound at 250 cycles per second (measured as *Hertz*, abbreviated as *Hz*) is equivalent to the musical pitch of middle C. The *spectrum* of a particular sound is the *specific* mix of all its component frequencies or pitches. A sound with strong components at high frequencies has a "brighter" quality compared with the same sound source with reduced high frequencies in its mix, which is heard as duller or muffled. An example is the muffled sound of a voice heard through a closed door.

### *Noise Criteria (NC)*

Noise Criteria are single number noise ratings of the *spectrum* of noise measured in rooms, applied most commonly to noise from ducted supply and return air flow and fans, i.e. the operation of mechanical systems serving a room, or by noise from the mechanical unit adjacent to an occupied room. NC levels for rooms can be predicted using standardized calculations (ASHRAE) or by using other predictive procedures. The higher the NC rating, the noisier or more annoying the background noise of the mechanical system. Measured NC values run anywhere from about 3 to 7 points lower than the A-weighted decibel sound level. However, unlike the measured decibel sound pressure level, the NC rating penalizes mechanical systems

for any peaks in the room’s noise spectrum, thereby arriving at a more accurate assessment of *noise annoyance* or noise distraction relative to the NC rating for noise which has no tonal or rumble peaks in its spectrum.

### *Spectrum Analysis*

Spectrum analysis is used to extract individual noise components from the overall measured noise level. Often the spectral components are no louder than the average noise level, but are easily detectable by the human ear due to their identifiable character, and are considered the primary cause of noise annoyance. Examples are the hum of transformers and whine from pumps.

Each component of noise is measured in a series of consecutive frequency bands. The bands may be linearly spaced or, more often, the bands are based on a doubling of frequencies, known as octave bands. The frequency of a band component is analogous to the pitch of a musical note. For example, the 250 Hertz (Hz) band is centered at the frequency of middle C and the 125 Hz band is one octave lower than middle C. Third octave band analysis (1/3 octave) further divides the sound components for finer detail in the spectral picture. When all frequency component decibel levels are summed together, using logarithmic addition rules, the total is equal to the overall noise level.

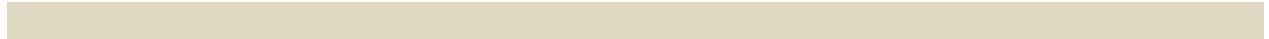

**Appendix B: HVAC Equipment—noise ratings**

**2 x 25,000 cfm air handlers:**

Sound								
Sound Power (db)								
Frequency	63 Hz	125 Hz	250 Hz	500 Hz	1 kHz	2 kHz	4 kHz	8 kHz
Inlet	88	89	80	78	74	68	60	53
Discharge	87	86	77	75	72	66	58	50
Radiated	-	94	91	89	89	86	83	82

**2 x 10,000 cfm air handlers**

Sound								
Sound Power (db)								
Frequency	63 Hz	125 Hz	250 Hz	500 Hz	1 kHz	2 kHz	4 kHz	8 kHz
Inlet	78	77	85	77	72	71	66	63
Discharge	84	83	88	83	81	78	73	68
Radiated	88	88	84	81	79	74	67	60

**Gym HRU (heat recovery unit)**

Unit Sound Power (dB)								
Type	63 Hz	125 Hz	250 Hz	500 Hz	1000 Hz	2000 Hz	4000 Hz	8000 Hz
Radiated:	73	74	77	65	62	54	46	51
Unit Discharge:	83	78	88	83	84	82	76	71
Unit Return:	73	74	77	65	65	65	57	56

**MAU for kitchen (make-up air system)**

**Sound Performance in Accordance with AMCA**

Fan	Sound Power by Octave Band								Lwa	dBA	Sones
	62.5	125	250	500	1000	2000	4000	8000			
Supply	87	88	87	83	81	78	77	70	87	76	27

**3 x Kitchen exhaust fans:**

**Sound Power by Octave Band**

Sound Data	62.5	125	250	500	1000	2000	4000	8000	LwA	dBA	Sones
Inlet	87	85	82	86	77	72	69	65	85	74	22

**3 x exhaust fans:**

**Sound Power by Octave Band**

Sound Data	62.5	125	250	500	1000	2000	4000	8000	LwA	dBA	Sones
Inlet	73	79	80	72	66	69	60	53	76	65	13.3

*Note:* The HVAC equipment ratings were provided during Schematic Design phase of the project, with final selection to be determined at completion of the mechanical system design.



**EXHIBIT F**  
**Preliminary Storm Water**  
**Drainage Report**

# PRELIMINARY Stormwater Drainage Report

## Sunset Primary School

Prepared for: West Linn Wilsonville School District  
Prepared by: Andrew Chung, Matt Johnson  
Project Engineer: Mark Wharry PE

January 2016 | KPFF Project #315087

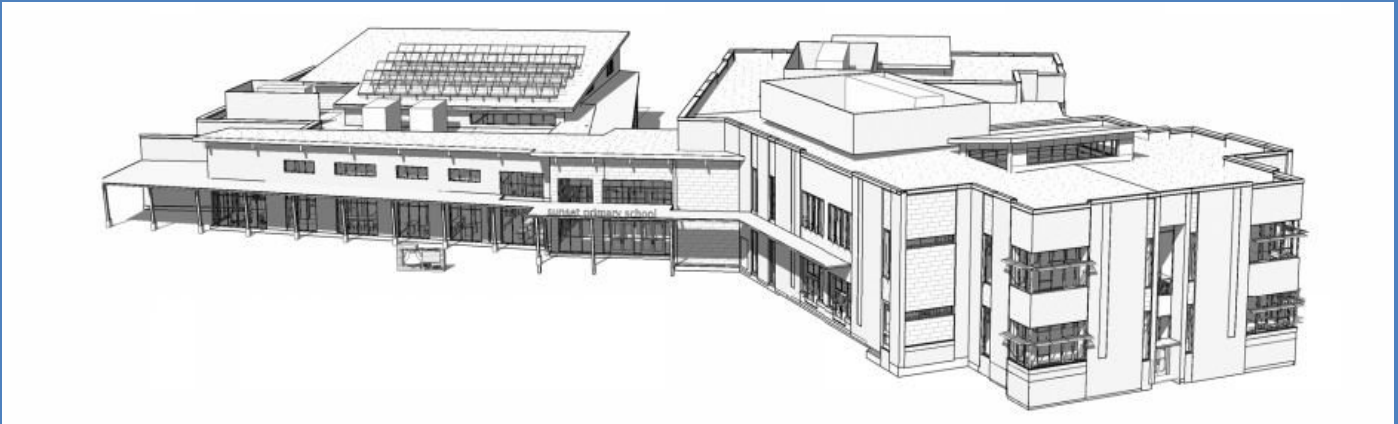

#### KPFF'S COMMITMENT TO SUSTAINABILITY

As a member of the US Green Building Council, a sustaining member of Oregon Natural Step, and a member of the Sustainable Products Purchasers Coalition, KPFF is committed to the practice of sustainable design and the use of sustainable materials in our work.

When hardcopy reports are provided by KPFF, they are prepared using recycled and recyclable materials, reflecting KPFF's commitment to using sustainable practices and methods in all of our products.





## Designer's Certification and Statement

"I hereby certify that this Stormwater Management Report for the Sunset Primary School project has been prepared by me or under my supervision and meets minimum standards of the City of West Linn and normal standards of engineering practice. I hereby acknowledge and agree that the jurisdiction does not and will not assume liability for the sufficiency, suitability, or performance of drainage facilities designed by me."

Mark Wharry, PE



## Table of Contents

I.	Project Overview and Description .....	3
II.	Methodology .....	3
III.	Analysis .....	4
IV.	Conveyance.....	5
V.	Conclusions .....	6

## Tables and Figures

Table 1A: Proposed Drainage Basin Area and WQ Flow Breakdown.....	4
Table 1B: Proposed Drainage Basin Peak Flow Rate Breakdown .....	4
Table 2: 24 Hour Rainfall Depths.....	4

## Appendices

### Figures

Vicinity Map

Basin Map

Storm Sewer Plans

### Appendix A

Hydrologic Analysis

### Appendix B

Infiltration Testing Results by Carlson

Geotechnical Report Prepared by Carlson

### Appendix C

Operations & Maintenance Report

## I. Project Overview and Description

The Sunset Primary School project is located at 2531 Oxford St. West Linn, Oregon. Currently, the site is occupied by the existing Sunset Primary school, baseball field, playground equipment and wooded area. The proposed project site is bound to the South by Oxford Street, Park Street, and Bittner Street, to the West by adjacent property, and to the North and East by woods (see Figure 1 – Vicinity Map). Currently, stormwater runoff from the project site is served by catch basins and surface runoff to public storm system on Exeter Street and Park Street.

The proposed project is an entire replacement of the Sunset Primary school building, asphalt parking lots, sidewalks, landscape, plays areas, and sports fields. All of this redevelopment will require stormwater treatment and detention. We propose one, adequately sized stormwater facility in order to meet City of West Linn Design Standards Section 2 Storm Drain requirements. The drainage area for the total project area is approximately 4.8 acres. In addition to the on-site improvements, the City of West Linn is requiring public utility and street improvements.

## II. Methodology

The City of West Linn Design Standards requires all new construction to mitigate the impact of the new impervious areas in vegetated stormwater facilities. To check for the feasibility of on-site infiltration, the geotechnical engineer was directed to perform on-site infiltration tests for the site. While the test results confirmed that 100% on-site infiltration is not possible, partial infiltration should be obtained by locating the facility in the vicinity of the better performing test pits. The City of West Linn Design Standards references City of Portland Stormwater Management Manual (SWMM) requirements for treatment of the “pollution reduction” rain event. This is achieved by the Presumptive Approach Calculation (PAC). The West Linn Design Standards for Flow Control state that the “post development discharge rate for the 2, 5, 10, and 25 year events shall be that of the pre-development discharge rate.” The following design option is proposed:

The proposed project will create impervious areas that will require a stormwater facility to treat and detain the runoff produced (see Figure 2 - Basin Map). A single stormwater pond will be used for water quality. Above this initial elevation, an orifice control structure will reside inside a flow control manhole to provide the required detention.

This project is analyzed as one basin based on proposed grades to convey all on-site stormwater to the rain garden in the South East corner of the site. Water Quality will be calculated using the City of Portland Presumptive Approach Calculator (PAC) and Water Quantity is evaluated using AutoDesk Storm and Sanitary Analysis 2016.

### III. Analysis

The hydrologic and hydraulic analyses were generated from a variety of sources including existing maps, field data, computer programs, standards, and reference manuals.

The hydraulic analyses were performed in accordance with City of West Linn Design Manual using the SBUH method with a 24-hour NRCS Type 1A synthetic rainfall distribution. The calculations were executed with the computer program AutoDesk Storm and Sanitary Analysis 2016 and City of Portland’s PAC Calculator. These methods were used to determine peak flows, pipe conveyance, facility sizing, and orifice flow control.

The total impervious areas for the site are approximately 2.98 acres. The project is analyzed as 1 basin as detailed in Table 1A and peak flows shown in Table 1B (see also Figure 2 – Basin Map). This project will treat stormwater in a rain garden and be flow controlled to new public storm main on Bittner Street (see storm plans).

Basin ID	Description	Area (acres)	C value (for impervious areas only)	Intensity (in/hr)	Pollution Reduction (CFS)
1	TOTAL AREA	2.98	0.98	0.19	0.54
<b>TOTALS</b>		<b>2.98</b>			

Table 1A: Proposed Drainage Basin Area

*Peak Flow Rate (cfs), ToC = 5 min*

Basin ID	2-year	5-year	10-year	25-year
1	1.85	2.25	2.66	3.07

\*Peak flows are from PAC and based on impervious areas only (see Appendix B).

Table 1B: Proposed Drainage Basin Peak Flow Rate Breakdown

The 24-hour rainfall depths used in this study were obtained from the City of West Linn Surface Water Management Plan.

Design Storm	24 Hour Rainfall (inches)
2-year	2.5
5-year	3.0
10-year	3.4
25-year	3.9
100-year	4.5

Table 2: 24-Hour Rainfall Depths (Source: City of West Linn Surface Water Management Plan)



Stormwater runoff is treated by use of a vegetated stormwater pond. This project proposes pollution reduction of all proposed impervious surfaces. The proposed pond has been designed using the City of Portland Presumptive Approach Calculator (See Appendix A).

Pond ID	Facility Bottom Area (SF)	Side Slope	25-year flow (cfs)	Pollution Reduction Flow (cfs)
1	2141	3:1	2.968	0.54

Carlson Geotechnical infiltration testing results

Infiltration Test Pit	Infiltration Result (inches/hour)
IT-1	3
IT-2	1
IT-3	11
IT-4	0
IT-5	3
IT-6	12

Since the exact rate of infiltration testing cannot accurately be determined without in-situ testing, we have conservatively estimated a ground disposal rate of three inches per hour. We then applied a Factor of Safety (FOS) of 2 to create the design infiltration rate of 1.5 inches per hour. This rate is incorporated into the water quality PAC calculation as well as the orifice controlled detention calculations.

## IV. Conveyance

All of the components of the storm system are sized to convey the 10-year design storm (Rational Method) per the City of West Linn Design Manual, which references City of Portland Sewer and Drainage Facilities Design Manual, Table 6.1 requirements. Below outlines the methods used for sizing flows and comparing pipe capacity:

Basin component	Method of Calculation	Reference Code
Basin Flow	Rational Method	Table 6.1, SDFDM*
Pipe Capacity	Manning's $Q = \frac{1.49}{n} A * R^{2/3} \sqrt{S}$	Equation 8.2, SDFDM*

\* = City of Portland Sewer and Drainage Facilities Design Manual (revised June 2007)

For pipes that have less than 3 feet of cover, ductile iron will be used in lieu of PVC.

Below is the information used for the conveyance calculations:

- The precipitation for the 10-year storm is 2.86 in/hr per City of Portland SDFDM Table 6.11.

- The “c” value for pavement/roofs is 0.98 and the “c” value for landscaped areas is 0.25.
- The minimum time of concentration is 5 minutes.

## V. Conclusions

Based on the compliance with the City of West Linn Storm Water Management Manual, City of West Linn Design Standards, City of Portland SWMM, feasibility, and proper engineering techniques, the stormwater runoff for The Sunset Primary School Project will be effectively managed. A single stormwater pond will be used for water quality and water quantity. The pond will have a total volume of 9,230 cubic feet of storage above the water quality requirement. This determination is supported by the PAC and SSA calculations. A conservative infiltration design rate was used for the calculations and design considerations. If higher rates are available, then higher performance and capacity of this pond will be achieved. The proposed pond discharge rates are controlled to the code required pre-development rates, and are substantially lower than the current school discharge rates. No downstream impacts are anticipated.

Development Condition	5 YEAR Qmax (cfs)	10 YEAR Qmax (cfs)	25 YEAR Qmax (cfs)	100 YEAR Qmax (cfs)
Lewis and Clark Pre-Development	0.90	1.21	1.63	2.16
Existing School Development	1.67	1.96	2.26	2.61
Proposed Development (un-detained)	1.88	2.41	2.74	3.17
Proposed Pond Discharge (detention)	0.77	1.01	1.31	2.26

This page left blank for double-sided printing

## Figures

Vicinity Map

Basin Map

Storm Sewer Plans

This page left blank for double-sided printing



# VICINITY MAP

N.T.S

3/16/16 PC Meeting



SHEET NO.  
**FIG 1**

11X17-EXHIBIT

This page left blank for double-sided printing

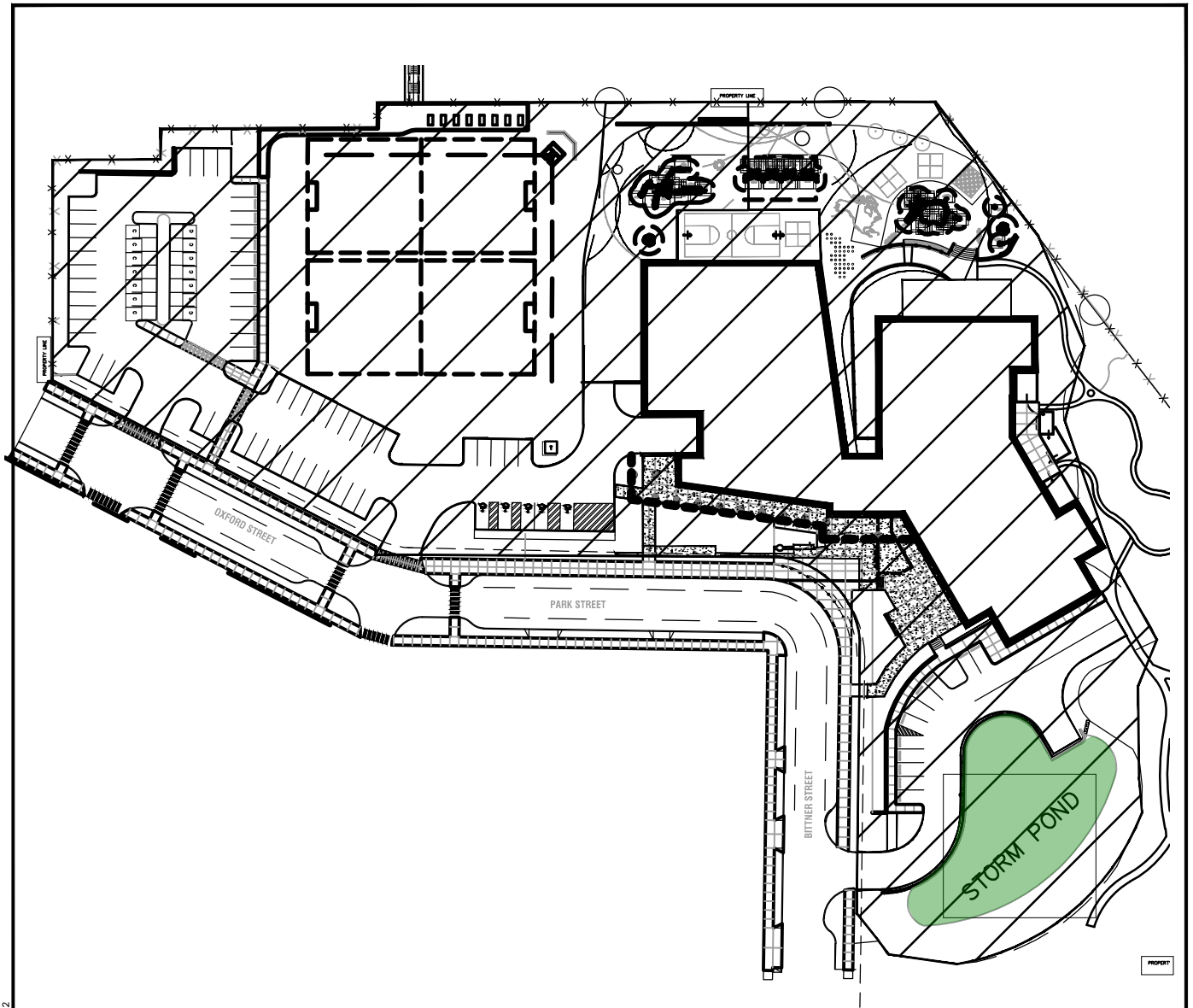

BASIN DATA	
TOTAL AREA:	225820 SF
IMPERVIOUS AREA:	128000 SF



# STORMWATER BASIN MAP

SUNSET PRIMARY SCHOOL  
FIG-2

File: N:\A\A\2015\15087-Sunset-Primary-School\PROJ-INFO\Planning-Design\01-Stormwater\BASIN\_MAP.dwg TAB:FIG-2

Plotted: 1/4/16 at 11:42am By: mattj



This page left blank for double-sided printing



WEST LINN WILSONVILLE

2755 SW Borland Road  
Tualatin, OR 97062  
(503) 673 7995



Dull Olson Weekes - IBI Group  
Architects, Inc.

907 SW Stark Street Portland OR 97205 USA  
tel 503 226 6950 Portland, OR 97204  
www.dowa-ibigroup.com fax 503 273 9192  
www.dowa-ibigroup.com www.ibigroup.com



111 SW Fifth Ave., Suite 2500  
Portland, OR 97204  
© 2003, 2011, 2015  
P: 503.274.4661  
www.kpff.com

PRELIMINARY  
NOT FOR  
CONSTRUCTION

SUNSET REVISIONING  
West Linn Wilsonville  
2351 Oxford St, West Linn, OR 97068  
t: (503) 673-7988

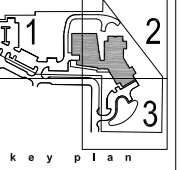

phase LAND USE

date JANUARY 8, 2016

revisions

project # 15015

STORM PLAN  
NORTHWEST

C6.01

**STORM KEYNOTES**

1. INSTALL STANDARD CLEANOUT.
2. INSTALL FLOW CONTROL MANHOLE.
3. INSTALL STANDARD 48" DIAMETER MANHOLE.
4. CONNECT TO BUILDING ROOF DRAIN STUB WITH PVC LATERAL. LATERAL TO BE 6" DIAMETER UNLESS OTHERWISE NOTED ON PLANS. SEE PLUMBING PLANS FOR CONTINUATION. CONFIRM DOWNSPOUT LOCATION WITH ARCHITECTURAL AND PLUMBING PLANS PRIOR TO CONSTRUCTION.
5. DAYLIGHT STORM PIPE.
6. CONNECT BUILDING SUB-DRAIN SYSTEM TO STORM DRAIN WITH SOLID WALL PVC PIPE, S=1% MINIMUM. SIZE TO MATCH SUB-DRAIN. INSTALL BACKWATER VALVE.
7. INSTALL BEEHIVE OVERFLOW INLET CATCH BASIN.
8. CONNECT RETAINING WALL SUB-SURFACE DRAIN TO STORM SYSTEM. SEE RETAINING WALL DRAWINGS FOR SUB-SURFACE DRAIN.
9. INSTALL UNDER SLAB SUBDRAINAGE PERFORATED PIPE SYSTEM.
10. RETAINING WALL SUBDRAINAGE. SEE RETAINING WALL PROFILES AND DETAILS. SHEETS C4.4 AND C4.5.
11. PROVIDE TRENCH DRAIN.
12. TRENCH DRAIN POINT OF CONNECTION. SEE STRUCTURE TABLE FOR LOCATION.

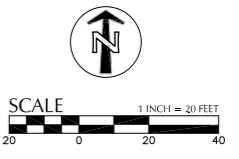
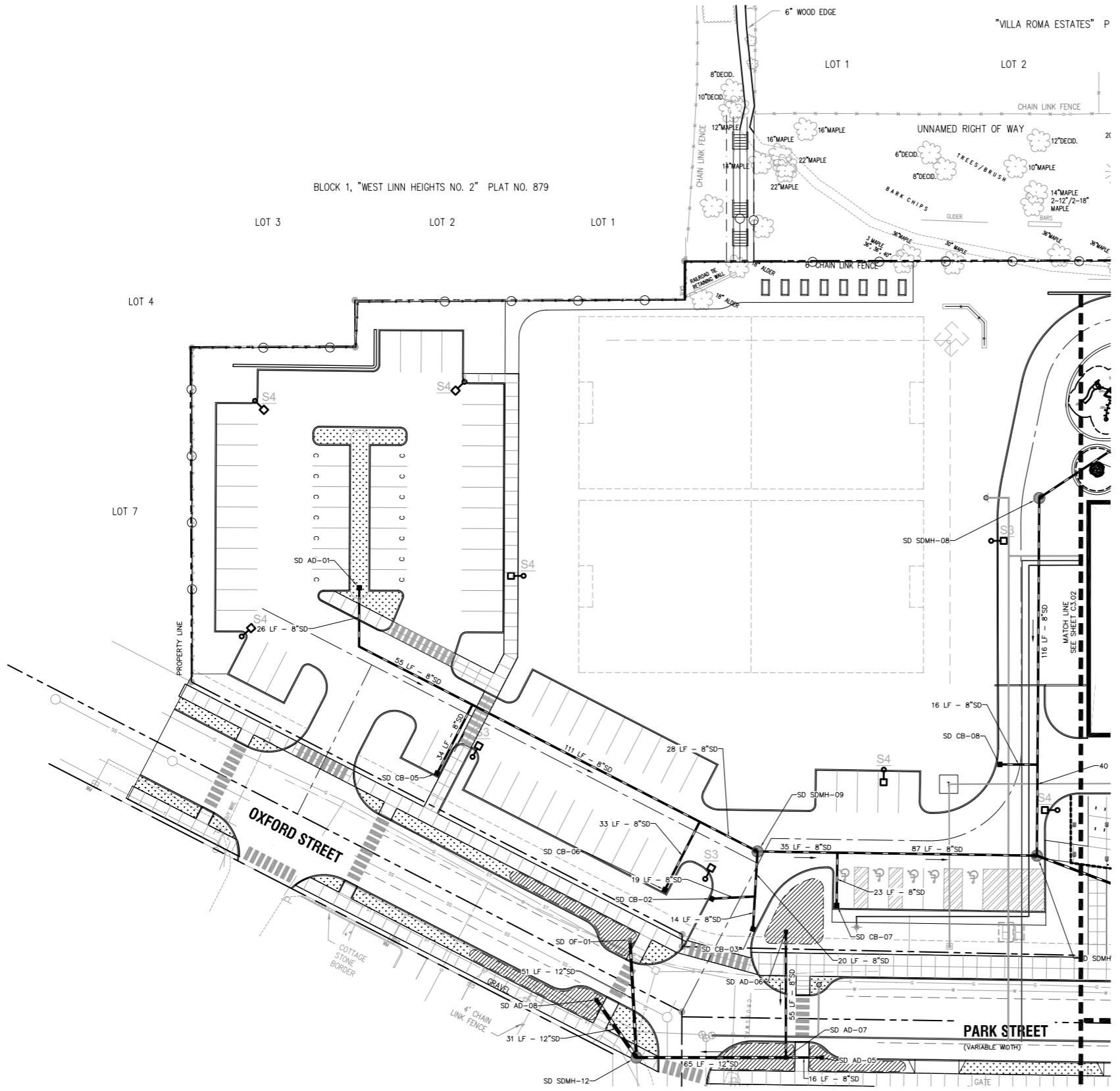

8/17/2015 8:49:42 AM  
N:\c\p\2015\15015\15015-Sunset-Primary-School-TRANS\IN20150810-REV1115-08-10 WLWW ARMS.rvt

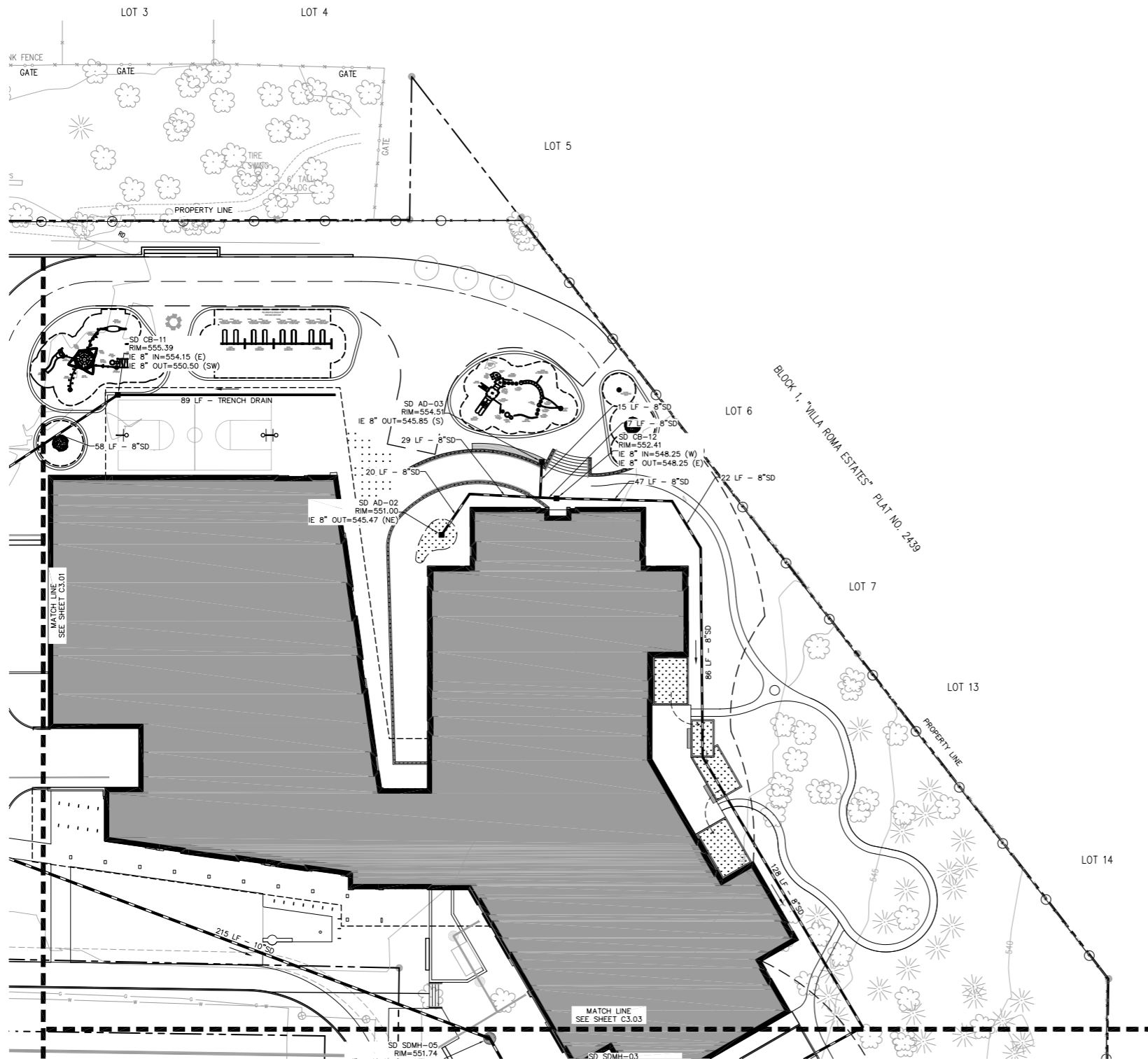

**STORM KEYNOTES**

1. INSTALL STANDARD CLEANOUT.
2. INSTALL FLOW CONTROL MANHOLE.
3. INSTALL STANDARD 48" DIAMETER MANHOLE.
4. CONNECT TO BUILDING ROOF DRAIN STUB WITH PVC LATERAL. LATERAL TO BE 6" DIAMETER UNLESS OTHERWISE NOTED ON PLANS. SEE PLUMBING PLANS FOR CONTINUATION. CONFIRM DOWNSPOUT LOCATION WITH ARCHITECTURAL AND PLUMBING PLANS PRIOR TO CONSTRUCTION.
5. DAYLIGHT STORM PIPE.
6. CONNECT BUILDING SUB-DRAIN SYSTEM TO STORM DRAIN WITH SOLID WALL PVC PIPE, S=1% MINIMUM. SIZE TO MATCH SUB-DRAIN. INSTALL BACKWATER VALVE.
7. INSTALL BEEHIVE OVERFLOW INLET CATCH BASIN.
8. CONNECT RETAINING WALL SUB-SURFACE DRAIN TO STORM SYSTEM. SEE RETAINING WALL DRAWINGS FOR SUB-SURFACE DRAIN.
9. INSTALL UNDER SLAB SUBDRAINAGE PERFORATED PIPE SYSTEM.
10. RETAINING WALL SUBDRAINAGE. SEE RETAINING WALL PROFILES AND DETAILS. SHEETS C4.4 AND C4.5.
11. PROVIDE TRENCH DRAIN.
12. TRENCH DRAIN POINT OF CONNECTION. SEE STRUCTURE TABLE FOR LOCATION.

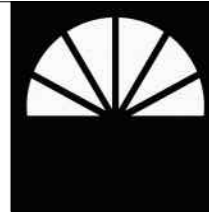

WEST LINN WILSONVILLE  
2755 SW Borland Road  
Tualatin, OR 97062  
(503) 673 7995



Dull Olson Weekes - IBI Group  
Architects, Inc.

907 SW Stark Street Portland OR 97205 USA  
tel 503 226 6950 fax 503 273 9192  
www.dowa-ibigroup.com www.ibigroup.com



111 SW Fifth Ave., Suite 2500  
Portland, OR 97204  
C: 503.227.3251  
F: 503.274.4681  
www.kpff.com

**PRELIMINARY  
NOT FOR  
CONSTRUCTION**

**SUNSET REVISIONING**  
**West Linn Wilsonville**  
2351 Oxford St, West Linn, OR 97068  
t: (503) 673-7988

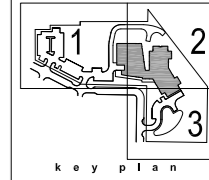

phase	DESIGN DEVELOPMENT
date	DECEMBER 22, 2015
revisions	
project #	15015

STORM PLAN  
NORTHEAST  
**C6.02**

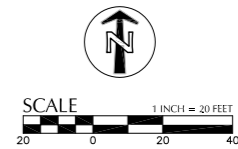

8/17/2015 8:49:12 AM  
N:\c\p\2015\15015\Sunset-Primary-School\FILE-TRANS\IN\20150810-REV\150810-WLWV-ARMS.rvt

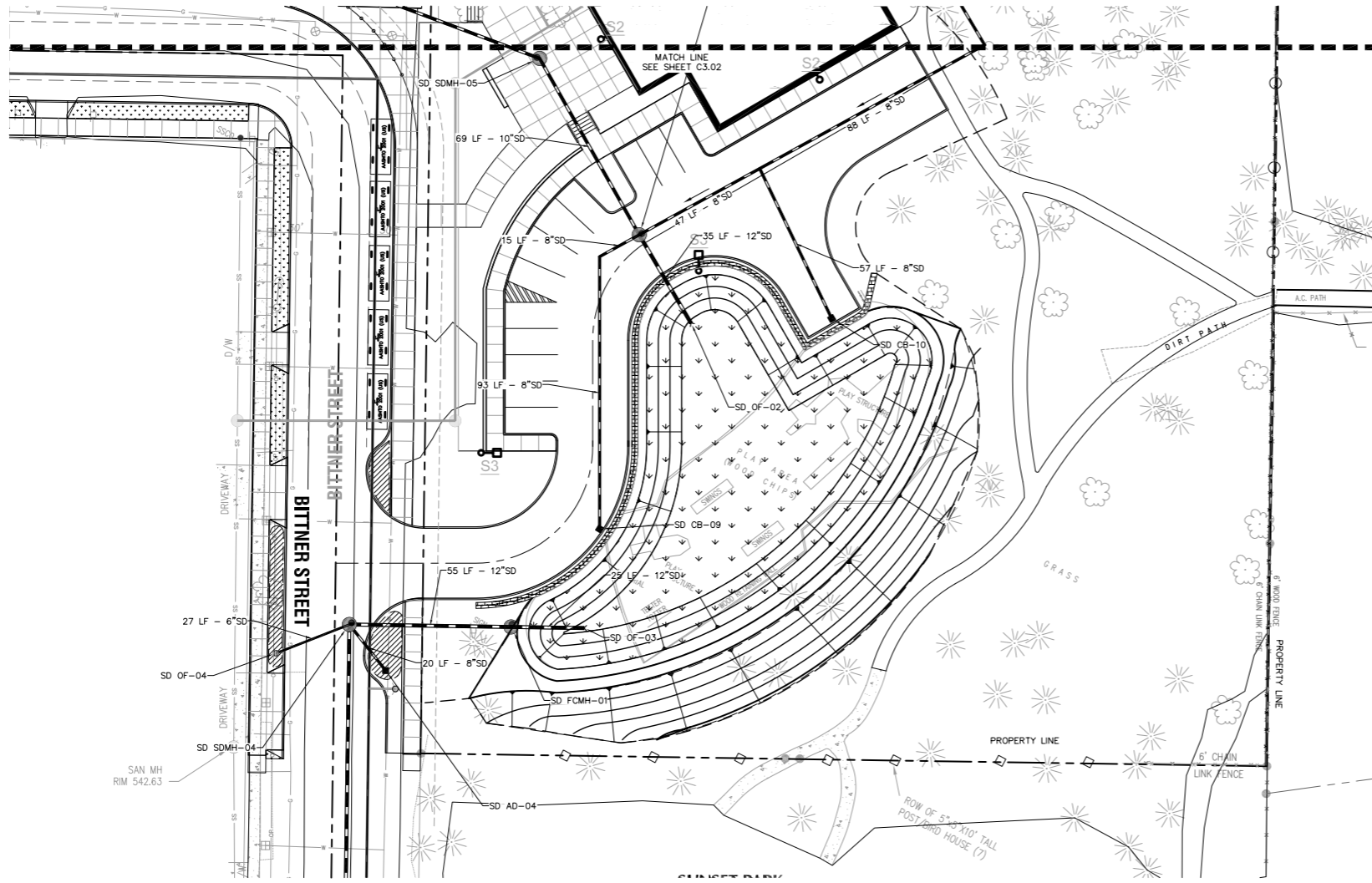

- STORM KEYNOTES**
1. INSTALL STANDARD CLEANOUT.
  2. INSTALL FLOW CONTROL MANHOLE.
  3. INSTALL STANDARD 48" DIAMETER MANHOLE.
  4. CONNECT TO BUILDING ROOF DRAIN STUB WITH PVC LATERAL. LATERAL TO BE 6" DIAMETER UNLESS OTHERWISE NOTED ON PLANS. SEE PLUMBING PLANS FOR CONTINUATION. CONFIRM DOWNSPOUT LOCATION WITH ARCHITECTURAL AND PLUMBING PLANS PRIOR TO CONSTRUCTION.
  5. DAYLIGHT STORM PIPE.
  6. CONNECT BUILDING SUB-DRAIN SYSTEM TO STORM DRAIN WITH SOLID WALL PVC PIPE, S=1% MINIMUM. SIZE TO MATCH SUB-DRAIN. INSTALL BACKWATER VALVE.
  7. INSTALL BEEHIVE OVERFLOW INLET CATCH BASIN.
  8. CONNECT RETAINING WALL SUB-SURFACE DRAIN TO STORM SYSTEM. SEE RETAINING WALL DRAWINGS FOR SUB-SURFACE DRAIN.
  9. INSTALL UNDER SLAB SUBDRAINAGE PERFORATED PIPE SYSTEM.
  10. RETAINING WALL SUBDRAINAGE. SEE RETAINING WALL PROFILES AND DETAILS. SHEETS C4.4 AND C4.5.
  11. PROVIDE TRENCH DRAIN.
  12. TRENCH DRAIN POINT OF CONNECTION. SEE STRUCTURE TABLE FOR LOCATION.



WEST LINN WILSONVILLE  
 2755 SW Borland Road  
 Tualatin, OR 97062  
 (503) 673 7995



Dull Olson Weekes - IBI Group  
 Architects, Inc.

907 SW Stark Street Portland OR 97205 USA  
 tel 503 226 6950 fax 503 273 9192  
 www.dowa-ibigroup.com www.ibigroup.com



111 SW Fifth Ave., Suite 2500  
 Portland, OR 97204  
 © 2013, 2012, 2011  
 P: 503.274.4681  
 www.kpff.com

**PRELIMINARY  
 NOT FOR  
 CONSTRUCTION**

**SUNSET REVISIONING**  
**West Linn Wilsonville**  
 2351 Oxford St, West Linn, OR 97068  
 t: (503) 673-7988

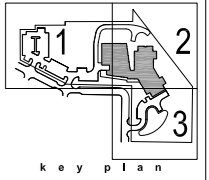

phase	LAND USE
date	JANUARY 8, 2016
revisions	
project #	15015

STORM PLAN  
 SOUTHEAST

**C6.03**

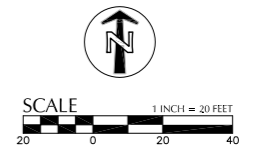

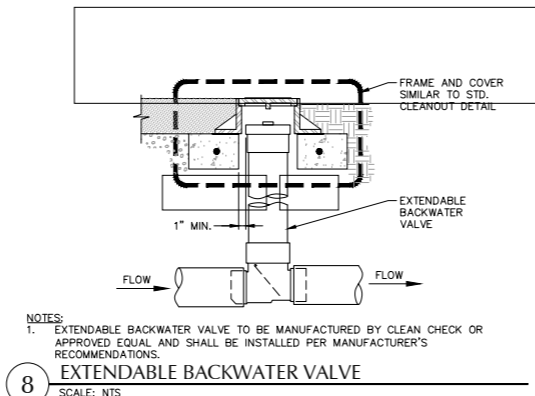

**8 EXTENDABLE BACKWATER VALVE**  
SCALE: NTS

NOTES:  
1. EXTENDABLE BACKWATER VALVE TO BE MANUFACTURED BY CLEAN CHECK OR APPROVED EQUAL AND SHALL BE INSTALLED PER MANUFACTURER'S RECOMMENDATIONS.

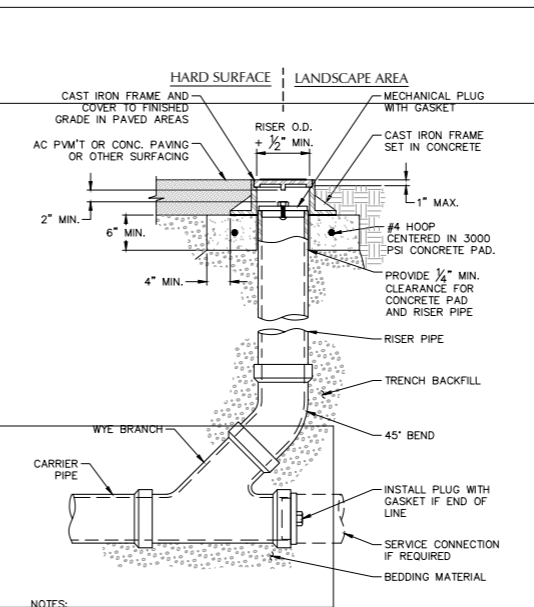

**5 STANDARD CLEANOUT (COTG)**  
SCALE: NTS

NOTES:  
1. CAST IRON FRAME AND COVER SHALL MEET H-20 LOAD REQUIREMENT.  
2. FOR CARRIER PIPE SIZE 6"Ø AND LESS, PROVIDE RISER PIPE SIZE TO MATCH CARRIER PIPE.  
3. FOR CARRIER PIPE SIZE 8"Ø AND LARGER, RISER PIPE SHALL BE 6"Ø.  
4. RISER PIPE MATERIAL TO MATCH CARRIER PIPE MATERIAL.

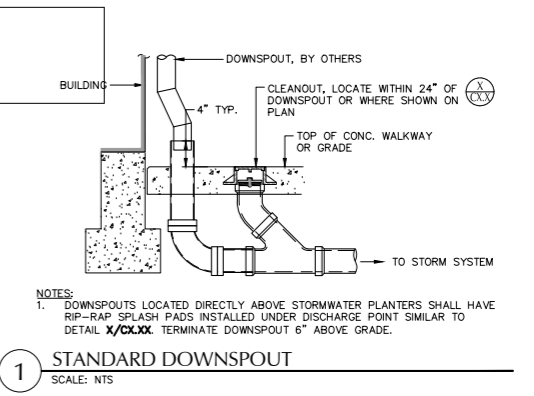

**1 STANDARD DOWNSPOUT**  
SCALE: NTS

NOTES:  
1. DOWNSPOUTS LOCATED DIRECTLY ABOVE STORMWATER PLANTERS SHALL HAVE RIP-RAP SPLASH PADS INSTALLED UNDER DISCHARGE POINT SIMILAR TO DETAIL X/CX.XX. TERMINATE DOWNSPOUT 6" ABOVE GRADE.

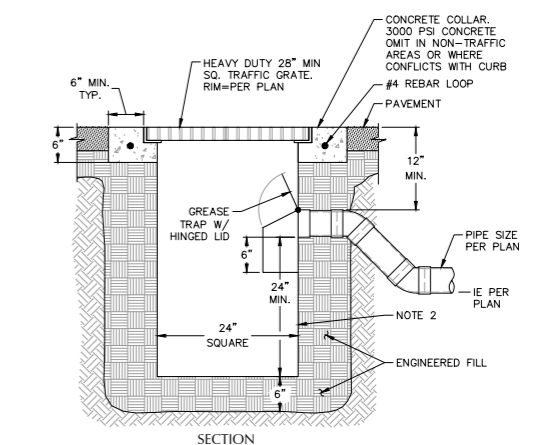

**2 TRAPPED CATCH BASIN**  
SCALE: NTS

NOTES:  
1. CONTRACTOR TO WIDEN EXCAVATION AS REQUIRED TO OBTAIN COMPACTION WITH CONTRACTORS COMPACTION EQUIPMENT.  
2. 1/4" STEEL PLATE, BITUMINOUS COATED, AS MANUFACTURED BY GIBSON STEEL BASINS OR APPROVED EQUAL.

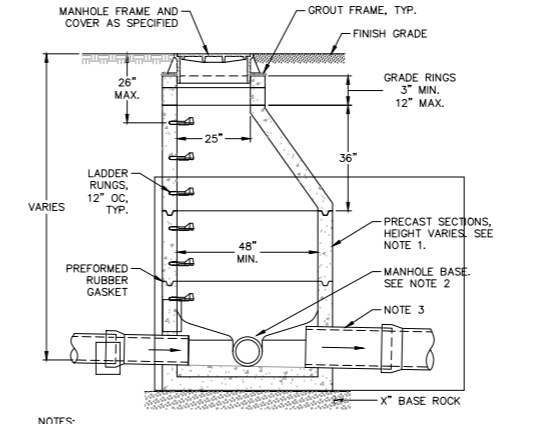

**6 STANDARD MANHOLE**  
SCALE: NTS

NOTES:  
1. ALL PRECAST SECTIONS SHALL CONFORM TO REQUIREMENTS OF ASTM C-478.  
2. MANHOLE BASE MAY BE PRECAST OR CAST IN PLACE. SEE STANDARD MANHOLE BASE DETAILS.  
3. ALL CONNECTING PIPES SHALL HAVE FLEXIBLE, GASKETED AND UNRESTRAINED JOINT WITHIN 18" OF MANHOLE VAULT.

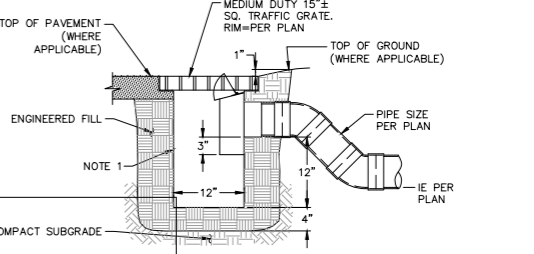

**3 TRAPPED AREA DRAIN**  
SCALE: NTS

NOTE:  
1. TO FACE STEEL PLATE, BITUMINOUS COATED, AS MANUFACTURED BY GIBSON STEEL BASINS OR APPROVED EQUAL.

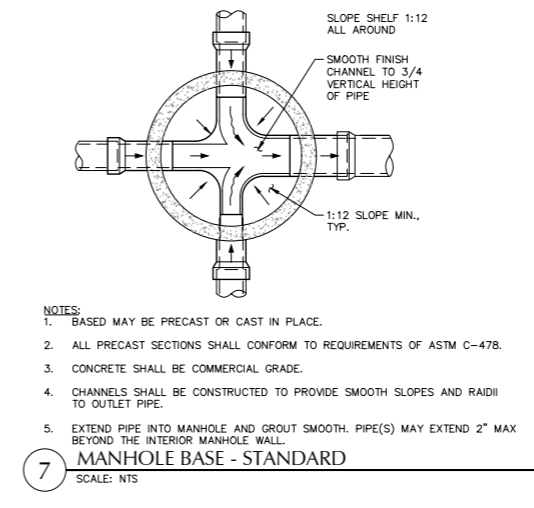

**7 MANHOLE BASE - STANDARD**  
SCALE: NTS

NOTES:  
1. BASED MAY BE PRECAST OR CAST IN PLACE.  
2. ALL PRECAST SECTIONS SHALL CONFORM TO REQUIREMENTS OF ASTM C-478.  
3. CONCRETE SHALL BE COMMERCIAL GRADE.  
4. CHANNELS SHALL BE CONSTRUCTED TO PROVIDE SMOOTH SLOPES AND RAIDII TO OUTLET PIPE.  
5. EXTEND PIPE INTO MANHOLE AND GROUT SMOOTH. PIPE(S) MAY EXTEND 2" MAX BEYOND THE INTERIOR MANHOLE WALL.

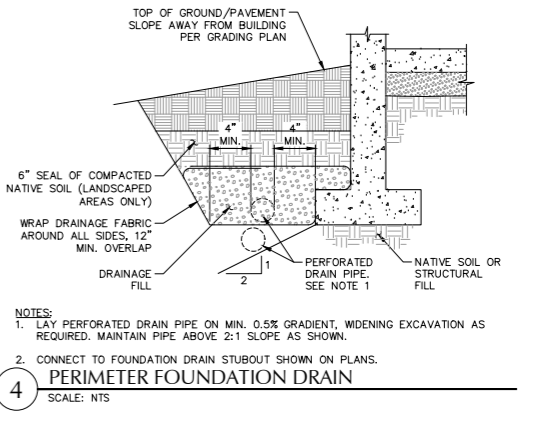

**4 PERIMETER FOUNDATION DRAIN**  
SCALE: NTS

NOTES:  
1. LAY PERFORATED DRAIN PIPE ON MIN. 0.5% GRADIENT, WIDENING EXCAVATION AS REQUIRED. MAINTAIN PIPE ABOVE 2:1 SLOPE AS SHOWN.  
2. CONNECT TO FOUNDATION DRAIN STUBOUT SHOWN ON PLANS.



WEST LINN WILSONVILLE  
2755 SW Borland Road  
Tualatin, OR 97062  
(503) 673 7995



Dull Olson Weekes - IBI Group Architects, Inc.  
907 SW Stark Street Portland OR 97205 USA  
tel 503 226 6950 fax 503 273 9192  
www.dowe-ibigroup.com www.ibigroup.com



111 SW Fifth Ave., Suite 2500  
Portland, OR 97204  
O: 503.227.3251  
F: 503.274.4681  
www.kpff.com

PRELIMINARY  
NOT FOR  
CONSTRUCTION

SUNSET REVISIONING  
West Linn Wilsonville  
2351 Oxford St. West Linn, OR 97068  
t: (503) 673-7988

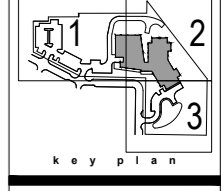

phase	DESIGN
DEVELOPMENT	
date	DECEMBER 22, 2015
revisions	
project #	15015

CIVIL DETAILS  
**C7.02**

8/17/2015 8:19:12 AM N:\c\p\2015\15015\Sunset-Primary-School\FILE-TRANS\IN\20150810-REV\115-08-10\W\W\A.R.M.S.mxd

# Appendix A

## Hydrologic Analysis

This page left blank for double-sided printing



**Calculation Spreadsheet:  
Summary  
Appendix B**

Sunset Primary School  
KPFJ Job #: 315087  
Designer: AC  
Check Engineer: MJ

**ASSUMPTIONS**

TR-55 Method Assumptions:

(used for water quality and detention sizing)

2-year Storm Event =	<b>2.5</b>	in/24-hours	Per 2006 City of West Linn Surface Water Management Plan
5-year Storm Event =	<b>3.0</b>	in/24-hours	
10-year Storm Event=	<b>3.4</b>	in/24-hours	
25-year Storm Event=	<b>3.9</b>	in/24-hours	
Roughness Coefficient =	<b>0.013</b>		
<u>Curve Number (CN):</u>			
Impervious Area =	<b>98</b>	Impervious	Per Technical Release Table 2-2a
Pervious Area =	<b>74</b>	Type C Soils:Good	

Rational Method Assumptions:

(used for conveyance pipe sizing)

Rainfall Intensity ( I )

25-year Storm Event =	<b>3.9</b>	in/hr	Per ODOT Hydraulics Manual, Ch 7, Appendix
-----------------------	------------	-------	---

Runoff Coefficient ( C )

Impervious Area =	<b>0.9</b>	Per ODOT Hydraulics Manual, Ch 7, Appendix
Pervious Area =	<b>0.25</b>	





**Calculation Spreadsheet:  
Summary  
Appendix B**

Sunset Primary School  
KPFJ Job #: 315087  
Designer: AC  
Check Engineer: MJ

**Detention Facility Design**

Bottom of Detention Facility modeled at bottom elevation = 0.00-ft  
Facility is a Flat Bottom amoeba shape with 3:1 side slopes

	Pre Developed Q	Post Developed	crest h (ft)	max depth (ft)	orifice size (in)	IE	Crown IE
		WQ					
2yr	0.55	2yr 0.50	0.50	1.35	4.5	0.50	0.88
5yr	0.90	5yr 0.77	1.35	1.69	4	1.35	1.68
10yr	1.21	10yr 1.01	1.70	1.93	3	1.70	1.95
25yr	1.63	25yr 1.31	1.95	2.23	3	1.95	2.20
100yr	2.16	100yr 2.26	2.25		8		

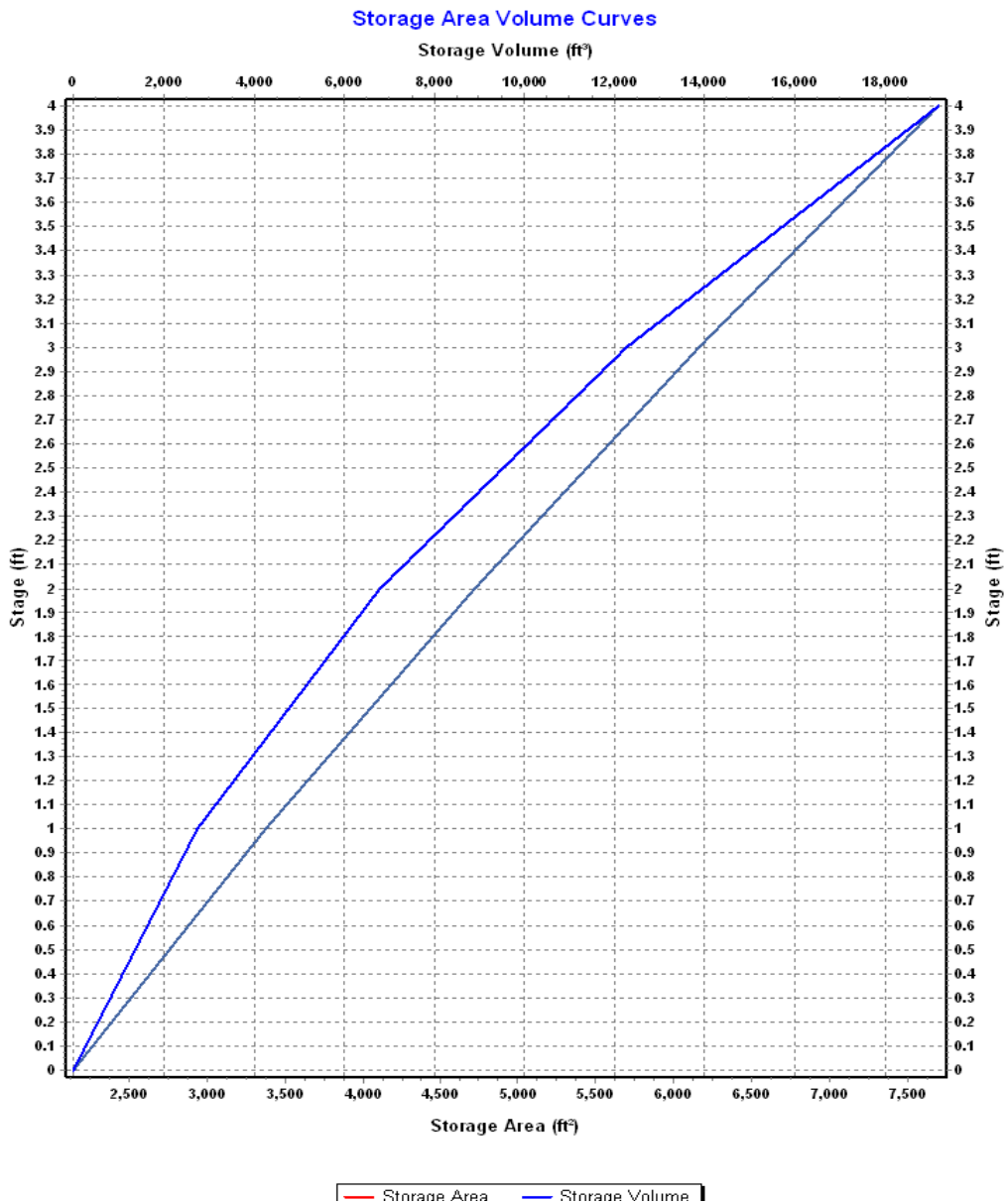



# Presumptive Approach Calculator ver. 1.2

Catchment Data

Project Name: **Sunset Primary School**  
 Project Address:   
 Designer: **Andrew Chung**  
 Company: **KPFF**

Catchment ID: **1**  
 Date: **12/15/15**  
 Permit Number: **0**

Run Time 12/15/2015 11:02:25 AM

Drainage Catchment Information		
Catchment ID	1	
	<b>Catchment Area</b>	
Impervious Area	128,000 SF	<b>Catchment Area Exceeds 1 Acre</b>
Impervious Area	2.94 ac	
Impervious Area Curve Number, $CN_{imp}$	98	
Time of Concentration, $T_c$ , minutes	5 min.	
Site Soils & Infiltration Testing Data		
Infiltration Testing Procedure:	Open Pit Falling Head	
Native Soil Field Tested Infiltration Rate ( $I_{test}$ ):	3 in/hr	
Bottom of Facility Meets Required Separation From High Groundwater Per BES SWMM Section 1.4:	Yes	
Correction Factor Component		
$CF_{test}$ (ranges from 1 to 3)	2	
Design Infiltration Rates		
$I_{dsgn}$ for Native ( $I_{test} / CF_{test}$ ):	1.50 in/hr	
$I_{dsgn}$ for Imported Growing Medium:	2.00 in/hr	

**Execute SBUH**

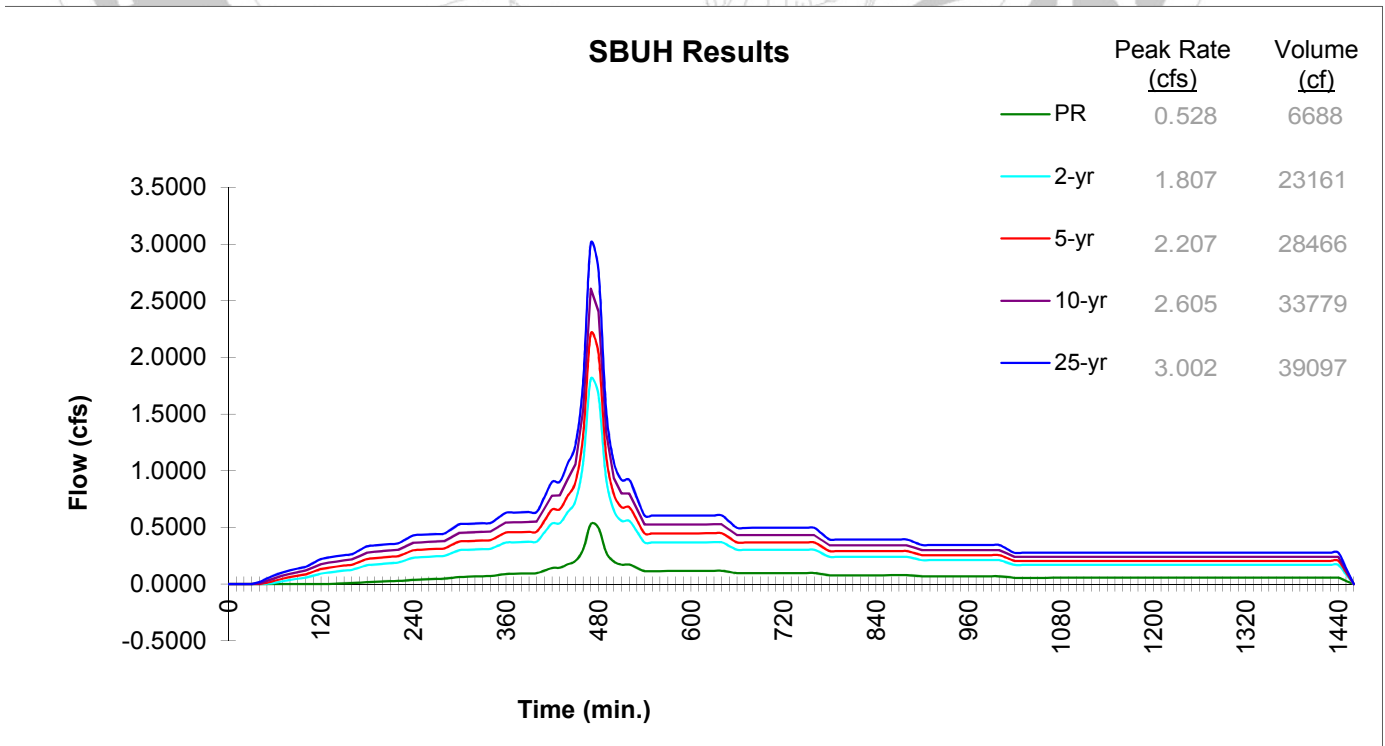



**Presumptive Approach Calculator ver. 1.2**

Catchment ID: **1**

Run Time 12/15/2015 11:02:25 AM

Project Name: **Sunset Primary School**

Catchment ID: **1**

Date: **12/15/2015**

**Instructions:**

1. Identify which Stormwater Hierarchy Category the facility.
2. Select Facility Type.
3. Identify facility shape of surface facility to more accurately estimate surface volume, except for Swales and sloped planters that use the PAC Sloped Facility Worksheet to enter data.
4. Select type of facility configuration.
5. Complete data entry for all highlighted cells.

Catchment facility will meet Hierarchy Category: **3**

Goal Summary:

Hierarchy Category	SWMM Requirement	RESULTS box below needs to display...	
		Pollution Reduction as a	10-yr (aka disposal) as a
3	Off-site flow to drainageway, river, or storm-only pipe system.	PASS	N/A

Facility Type = **Basin**

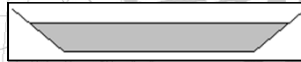

Facility Shape: **Amoeba**

Facility Configuration: **A**

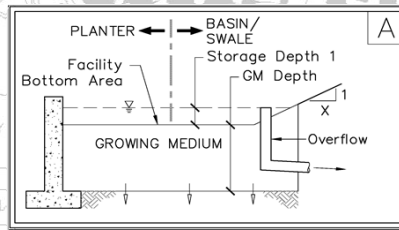
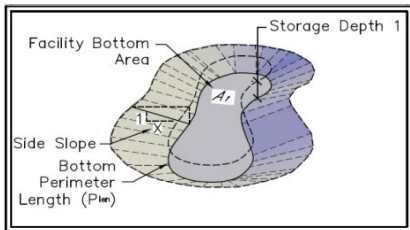

Calculation Guide  
Max. Rock Stor.  
Bottom Area  
**3,032 SF**

**DATA FOR ABOVE GRADE STORAGE COMPONENT**

Facility Bottom Area = **2,141** sf  
 Bottom Perimeter Length = **297.0** ft  
 Facility Side Slope = **3** to **1**  
 Storage Depth 1 = **6** in  
 Growing Medium Depth = **18** in  
 Freeboard Depth = **12** in

**BELOW GRADE STORAGE**

Rock Storage Bottom Area = **2,809** sf  
 Rock Storage Depth = **0** in

Surface Capacity at Depth 1 = **1,293** cf  
 Infiltration Area at 75% Depth1 = **2,809** SF  
 GM Design Infiltration Rate = **2.00** in/hr  
 Infiltration Capacity = **0.130** cfs

Rock Storage Capacity = **0** cf

Native Design Infiltration Rate = **1.50** in/hr  
 Infiltration Capacity = **0.098** cfs

**Native Infiltration Rate Used in PA**

RESULTS		Overflow Volume	
Pollution Reduction	<b>PASS</b>	0 CF	<b>94%</b> Surf. Cap. Used
<a href="#">Run PAC</a>			
Output File			
Peak cfs	<b>2-yr</b> 1.710	<b>5-yr</b> 2.110	<b>10-yr</b> 2.508
		<b>25-yr</b> 2.904	

FACILITY FACTS	
Total Facility Area Including Freeboard =	<b>3,478 SF</b>
Sizing Ratio (Total Facility Area / Catchment Area) =	<b>0.027</b>

# Stormwater Peak Flow Rates and Volumes

## PRE 2 YR STORM

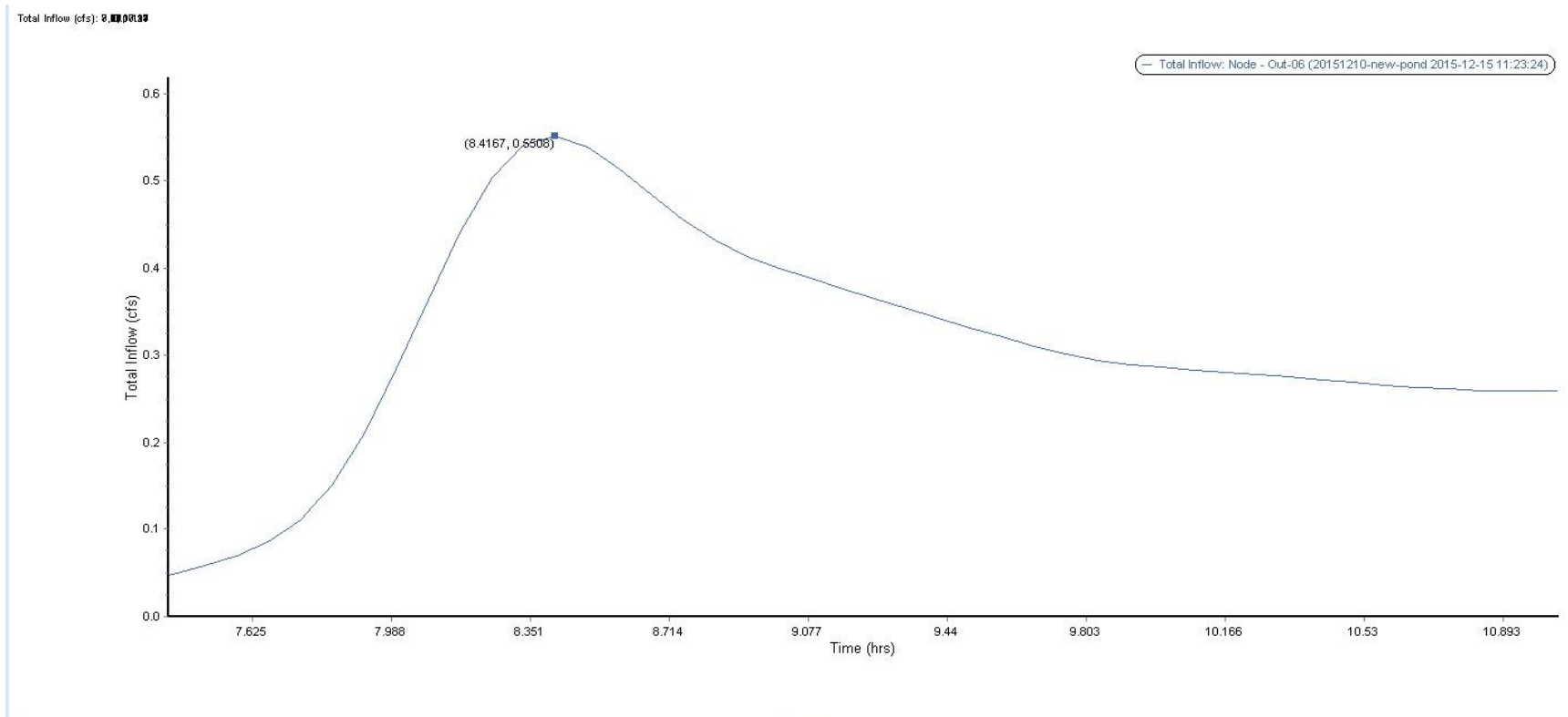

Total Inflow Summary Table

Time period		Element ID	Out-06
From:	04/28/2015, 12:00:00 AM	Maximum Total Inflow (cfs)	0.55
To:	04/29/2015, 12:00:00 AM	Minimum Total Inflow (cfs)	0.00
Thresholds		Event Mean Total Inflow (cfs)	0.16
Exceedance:	0	Duration of Exceedances (hrs)	N/A
Deficit:	0	Duration of Deficits (hrs)	N/A
Detention storage		Number of Exceedances	N/A
Max flow:	0	Number of Deficits	N/A
		Volume of Exceedance (ft³)	N/A
		Volume of Deficit (ft³)	N/A
		Total Inflow Volume (ft³)	13913.62
		Detention Storage (ft³)	N/A

# Stormwater Peak Flow Rates and Volumes

POST 2 YR STORM

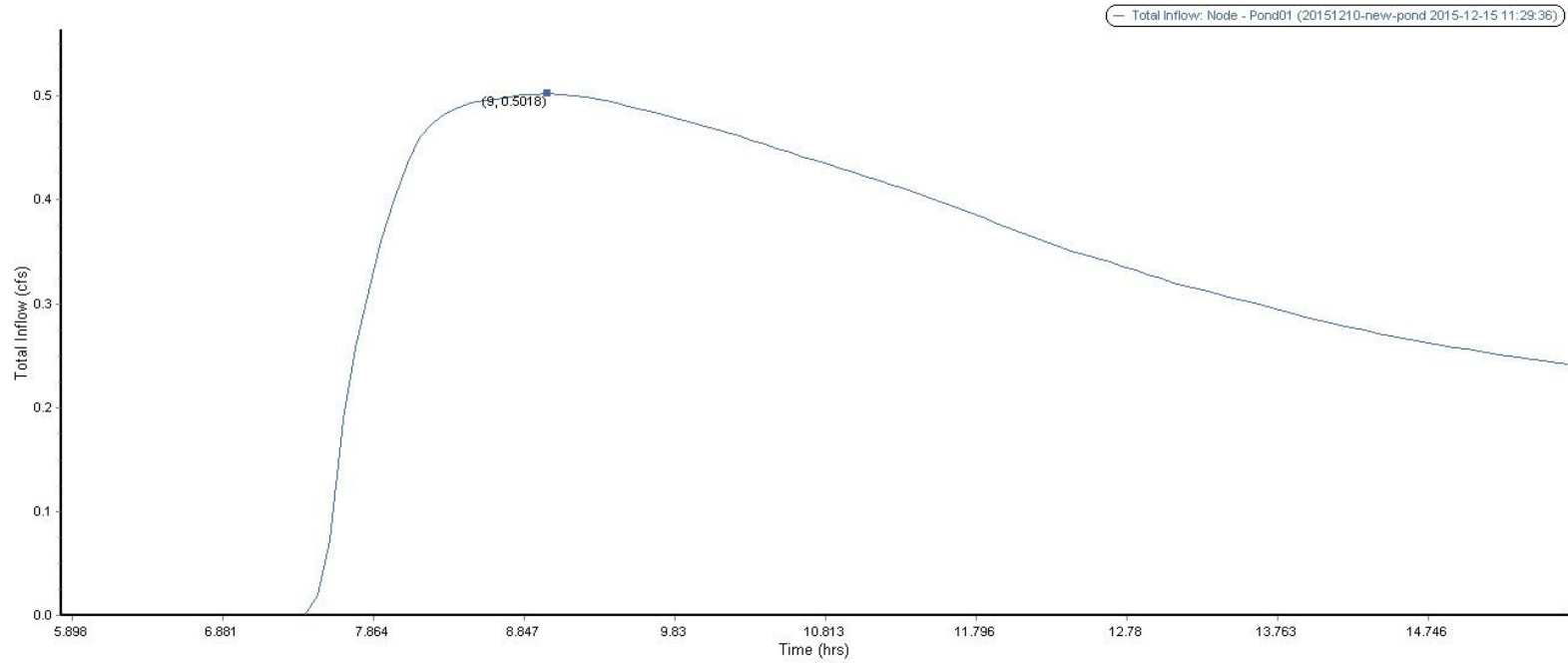

Total Inflow Summary Table	
<b>Time period</b>	<b>Element ID</b> Pond01
From: 04/28/2015, 12:00:00 AM	Maximum Total Inflow (cfs) 0.50
To: 04/29/2015, 12:00:00 AM	Minimum Total Inflow (cfs) 0.00
<b>Thresholds</b>	Event Mean Total Inflow (cfs) 0.19
Exceedance: 0	Duration of Exceedances (hrs) N/A
Deficit: 0	Duration of Deficits (hrs) N/A
<b>Detention storage</b>	Number of Exceedances N/A
Max flow: 0	Number of Deficits N/A
	Volume of Exceedance (ft³) N/A
	Volume of Deficit (ft³) N/A
	Total Inflow Volume (ft³) 16102.74
	Detention Storage (ft³) N/A

# Stormwater Peak Flow Rates and Volumes

PRE 5 YR STORM

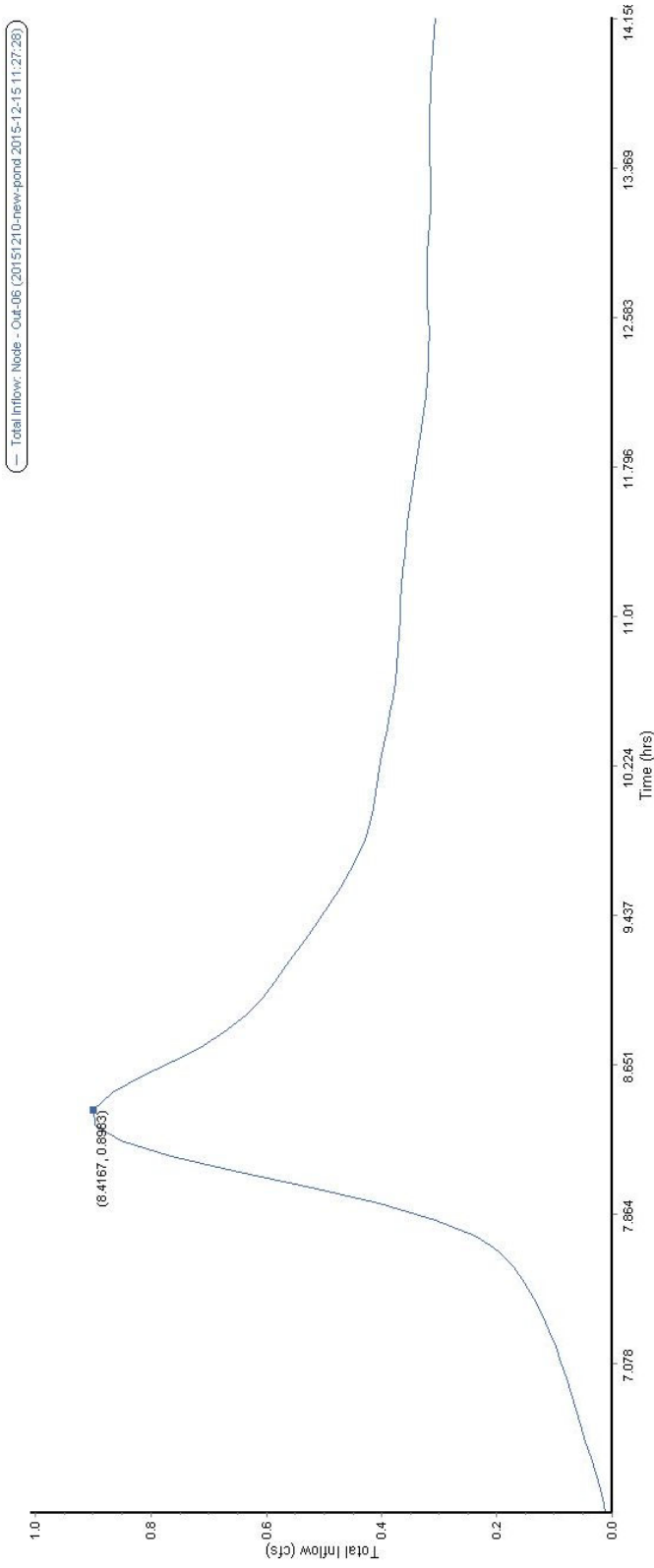

Time period		Total Inflow Summary Table	
From:	04/28/2015, 12:00:00 AM	Element ID	Out-06
To:	04/29/2015, 12:00:00 AM	Minimum Total Inflow (cfs)	0.90
Thresholds		Minimum Total Inflow (cfs)	0.00
Exceedance:	0	Event Mean Total Inflow (cfs)	0.23
Deficit:	0	Duration of Exceedances (hrs)	N/A
Detention storage		Duration of Deficits (hrs)	N/A
Max flow:	0	Number of Exceedances	N/A
		Number of Deficits	N/A
		Volume of Exceedance (ft³)	N/A
		Volume of Deficit (ft³)	N/A
		Total Inflow Volume (ft³)	19969.39
		Detention Storage (ft³)	N/A

# Stormwater Peak Flow Rates and Volumes

## POST 5 YR STORM

Total Inflow: Node - Pond01 (20151210-new-pond.2015-12-15 11:31:50)

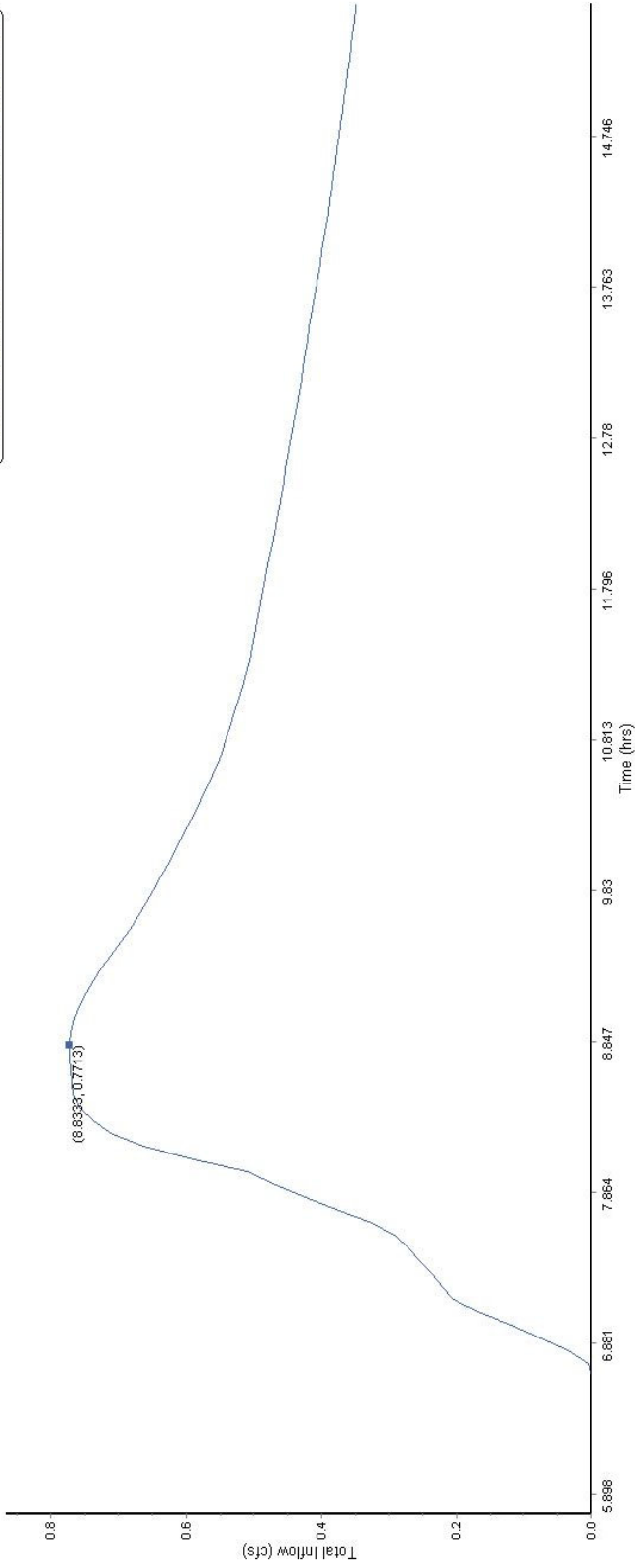

Time period		Element ID	
From:	04/28/2015, 12:00:00 AM	Pond01	
To:	04/29/2015, 12:00:00 AM	Maximum Total Inflow (cfs)	0.77
Thresholds		Minimum Total Inflow (cfs)	0.00
Exceedance:	0	Event Mean Total Inflow (cfs)	0.27
Deficit:	0	Duration of Exceedances (hrs)	N/A
Duration of Exceedances	N/A	Duration of Deficits (hrs)	N/A
Number of Exceedances	N/A	Number of Deficits	N/A
Volume of Exceedance (ft³)	N/A	Volume of Deficit (ft³)	N/A
Volume of Deficit (ft³)	N/A	Total Inflow Volume (ft³)	23156.12
Max. flow:	0	Detention Storage (ft³)	N/A

**Total Inflow Summary Table**

# Stormwater Peak Flow Rates and Volumes

PRE 10 YR STORM

— Total Inflow, Node - Out-06 (20151210-new-pond 2015-12-15 11:28:08)

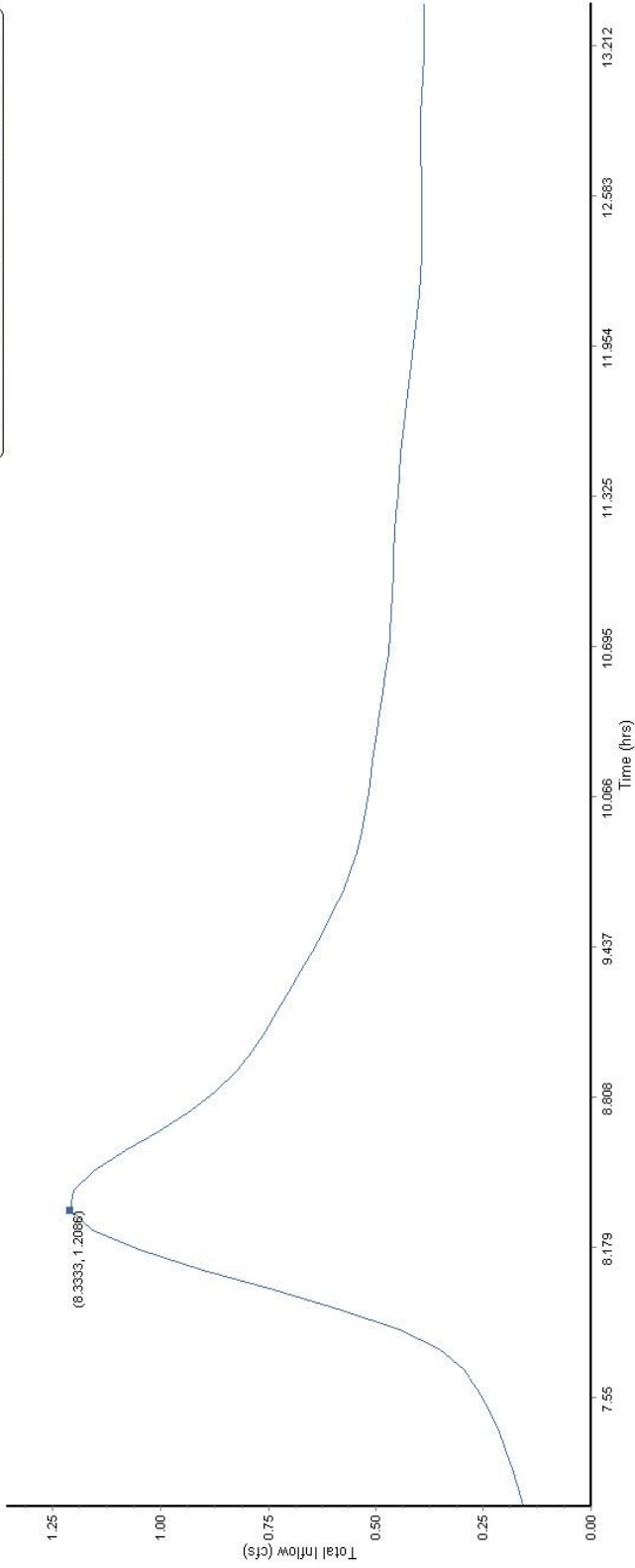

Total Inflow Summary Table

Element ID	Out-06
Maximum Total Inflow (cfs)	1.21
Minimum Total Inflow (cfs)	0.00
Event Mean Total Inflow (cfs)	0.29
Duration of Exceedances (hrs)	N/A
Duration of Deficits (hrs)	N/A
Number of Exceedances	N/A
Number of Deficits	N/A
Volume of Exceedance (ft³)	N/A
Volume of Deficit (ft³)	N/A
Total Inflow Volume (ft³)	25179.38
Detention Storage (ft³)	N/A

Time period	
From:	04/28/2015, 12:00:00 AM
To:	04/29/2015, 12:00:00 AM
Thresholds	
Exceedance:	0
Deficit:	0
Detention storage	
Max flow:	0



# Stormwater Peak Flow Rates and Volumes

POST 10 YR STORM

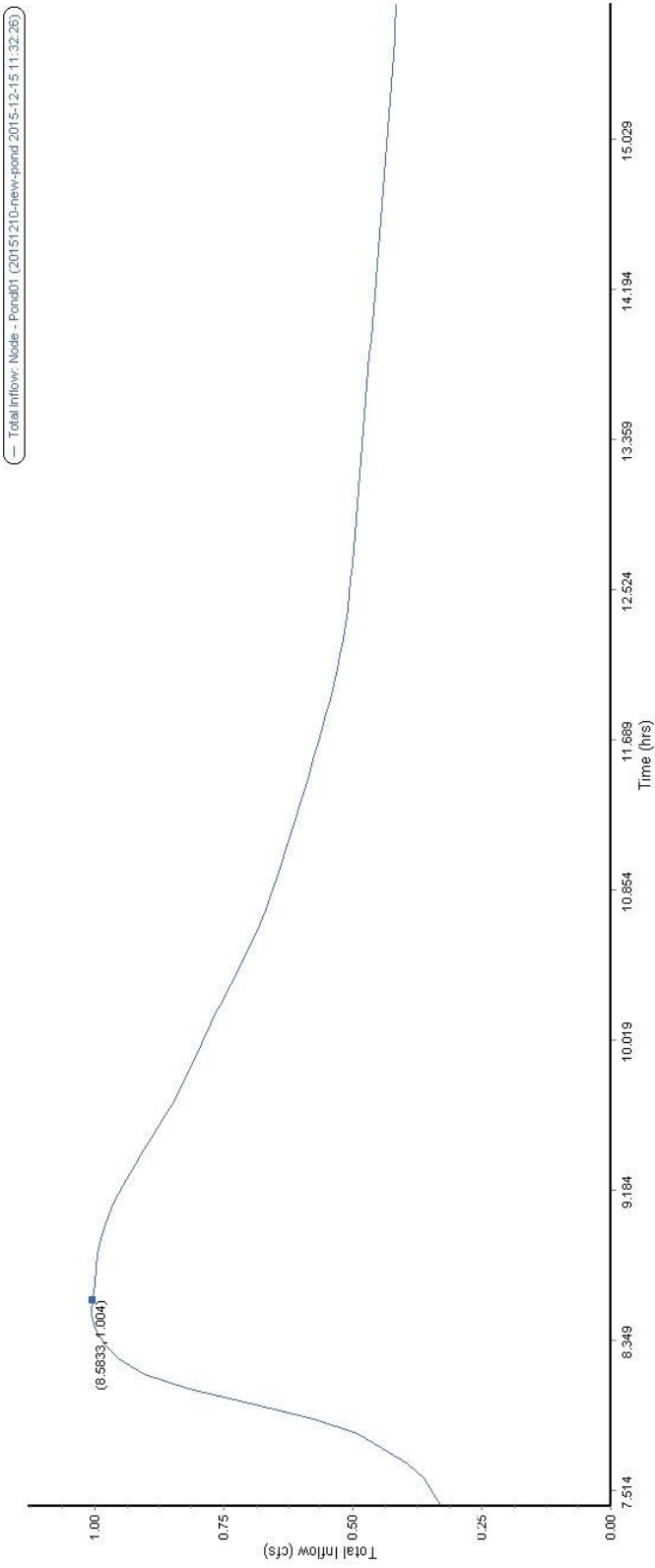

**Total Inflow Summary Table**

Element ID	Pond01
Maximum Total Inflow (cfs)	1.01
Minimum Total Inflow (cfs)	0.00
Event Mean Total Inflow (cfs)	0.34
Duration of Exceedances (hrs)	N/A
Duration of Deficits (hrs)	N/A
Number of Exceedances	N/A
Number of Deficits	N/A
Volume of Exceedance (ft³)	N/A
Volume of Deficit (ft³)	N/A
Total Inflow Volume (ft³)	26928.35
Detention Storage (ft³)	N/A

  

Time period	
From:	04/28/2015, 12:00:00 AM
To:	04/29/2015, 12:00:00 AM
Thresholds	
Exceedance:	0
Deficit:	0
Detention storage	
Max flow:	0

# Stormwater Peak Flow Rates and Volumes

## PRE 25 YR STORM

Total Inflow (cfs): 8.42, 1.63

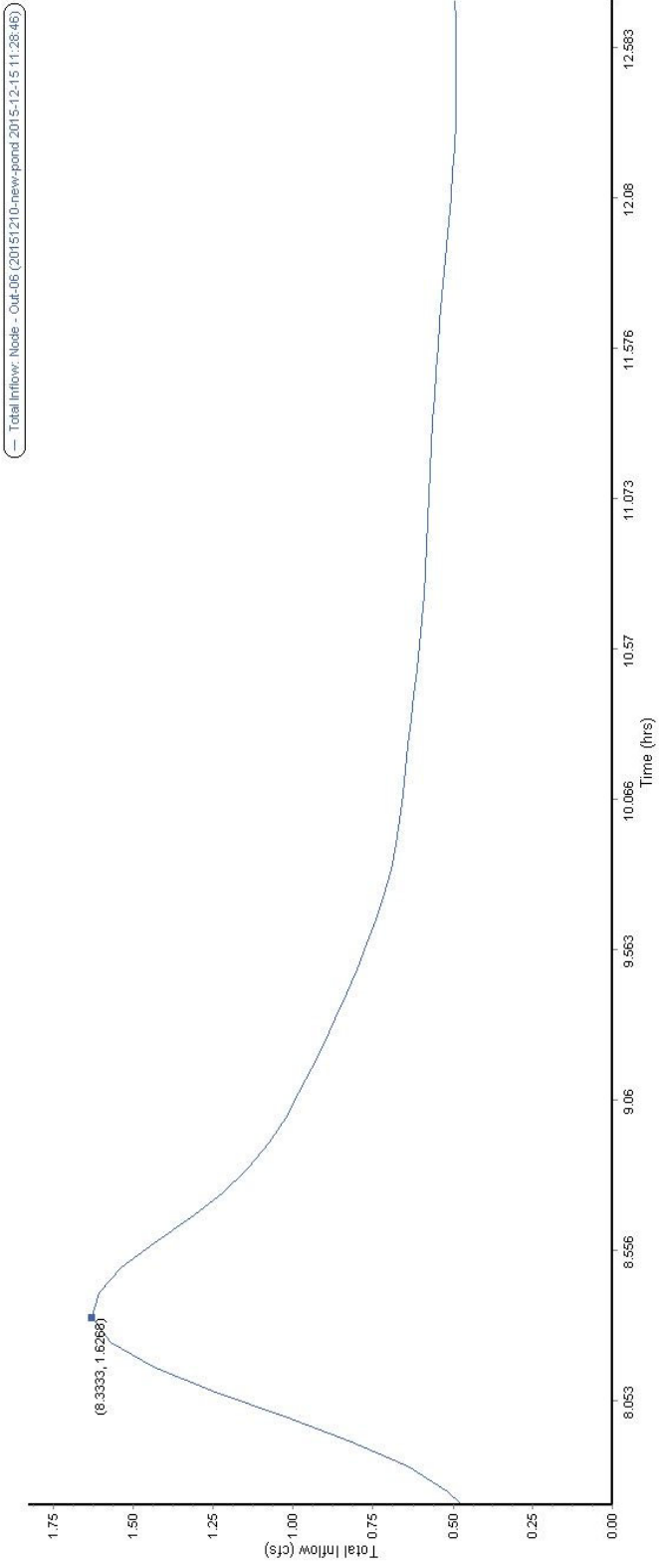

### Total Inflow Summary Table

Time period	Element ID	Out-06
From: 04/28/2015, 12:00:00 AM	Maximum Total Inflow (cfs)	1.63
To: 04/29/2015, 12:00:00 AM	Minimum Total Inflow (cfs)	0.00
Thresholds	Event Mean Total Inflow (cfs)	0.37
Exceedance: 0	Duration of Exceedances (hrs)	N/A
Deficit: 0	Duration of Deficits (hrs)	N/A
Detention storage	Number of Exceedances	N/A
Max flow: 0	Number of Deficits	N/A
	Volume of Exceedance (ft³)	N/A
	Volume of Deficit (ft³)	N/A
	Total Inflow Volume (ft³)	32044.13
	Detention Storage (ft³)	N/A

# Stormwater Peak Flow Rates and Volumes

POST 25 YR STORM

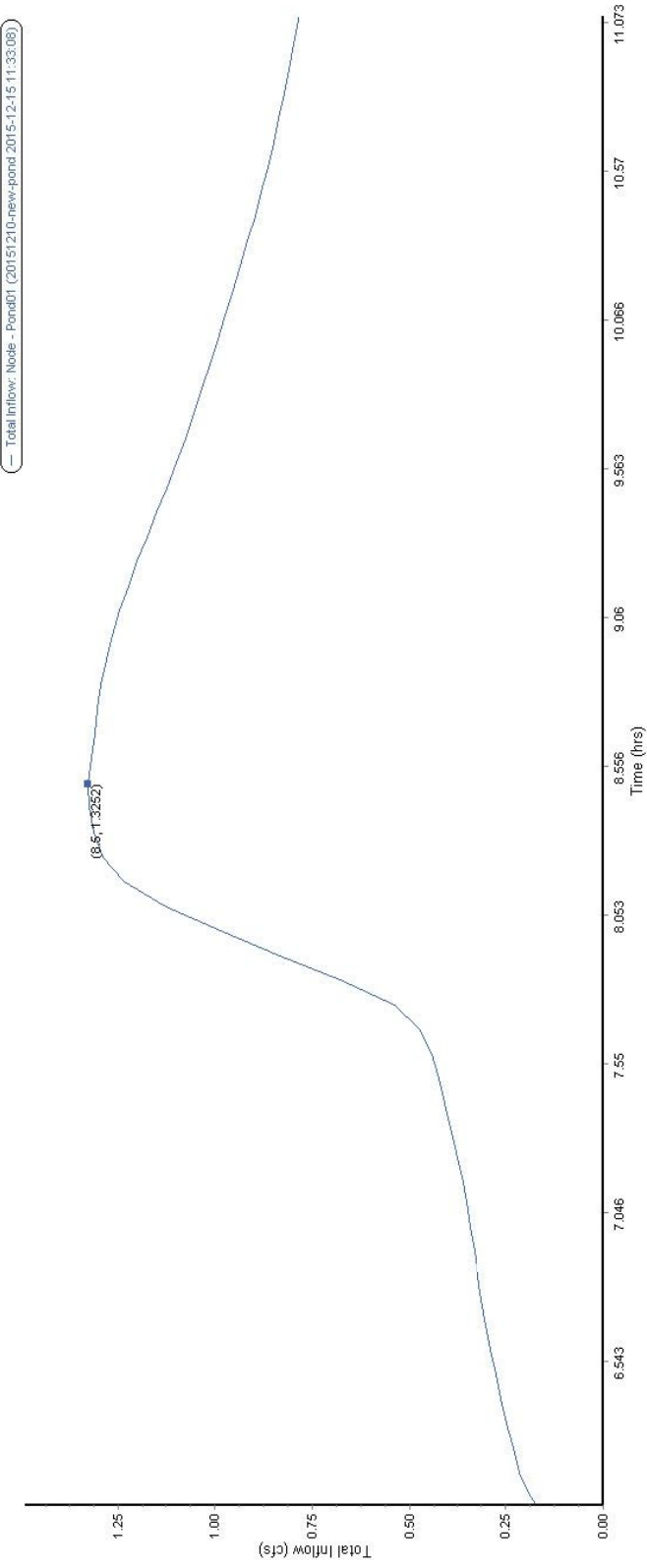

**Total Inflow Summary Table**

Time period	From: 04/28/2015, 12:00:00 AM	To: 04/29/2015, 12:00:00 AM
Thresholds	Exceedance: 0	Deficit: 0
Detention storage	Max flow: 0	
Element ID	Pond01	
Maximum Total Inflow (cfs)	1.33	
Minimum Total Inflow (cfs)	0.00	
Event Mean Total Inflow (cfs)	0.42	
Duration of Exceedances (hrs)	N/A	
Duration of Deficits (hrs)	N/A	
Number of Exceedances	N/A	
Number of Deficits	N/A	
Volume of Exceedance (ft³)	N/A	
Volume of Deficit (ft³)	36176.85	
Total Inflow Volume (ft³)	N/A	
Detention Storage (ft³)	N/A	

## **Appendix B**

Infiltration Testing Results by GRI

Geotechnical Report Prepared by GRI

Page left blank for double-sided printing.

# Appendix C

## Operations & Maintenance Report

This page left blank for double-sided printing.

# PRELIMINARY Operation and Maintenance Plan

## Sunset Primary School

Prepared for: West Linn Wilsonville School District

Prepared by: Andrew Chung, Matt Johnson

Project Engineer: Mark Wharry PE

January 2016 | KPFF Project #315087

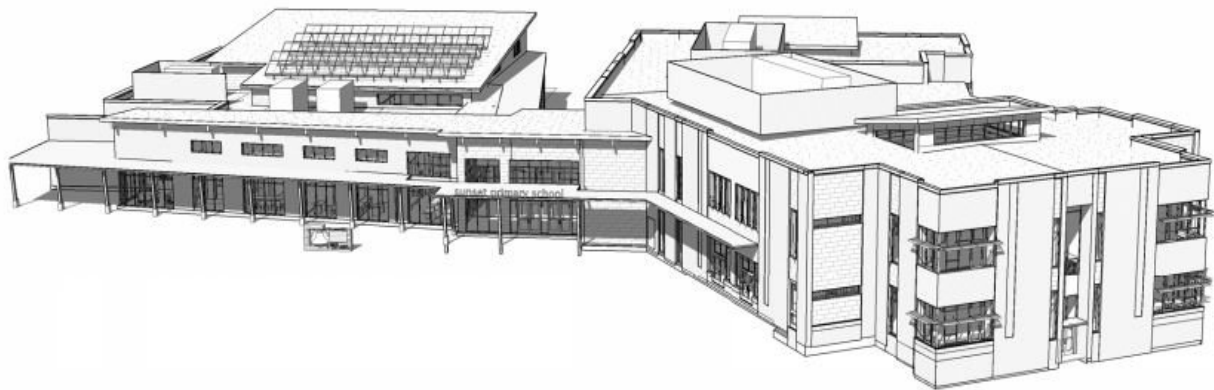



#### KPFF'S COMMITMENT TO SUSTAINABILITY

As a member of the US Green Building Council, a sustaining member of Oregon Natural Step, and a member of the Sustainable Products Purchasers Coalition, KPFF is committed to the practice of sustainable design and the use of sustainable materials in our work.

When hardcopy reports are provided by KPFF, they are prepared using recycled and recyclable materials, reflecting KPFF's commitment to using sustainable practices and methods in all of our products.



## Table of Contents

I.	Description .....	4
II.	Schedule.....	4
III.	Inspection and Maintenance Procedures.....	5
IV.	Financial Responsibilities.....	5

## Appendix

Appendix A

Facilities Specifications

Appendix B

Inspection Log

## I. Description

The Sunset Primary School project is located at 2531 Oxford St. West Linn, Oregon. Currently, the site is occupied by the existing Sunset Primary school, baseball field, playground equipment and wooded area. The proposed project site is bound to the South by Oxford Street, Park Street, and Bittner Street, to the West by adjacent property, and to the North and East by woods (see Figure 1 – Vicinity Map). Currently, stormwater runoff from the project site is served by catch basins and surface runoff to public storm system on Exeter Street and Park Street.

The proposed project is an entire replacement of the Sunset Primary school building, asphalt parking lots, sidewalks, landscape, plays areas, and sports fields. All of this redevelopment will require stormwater treatment and detention. We propose one, adequately sized stormwater facility in order to meet City of West Linn Design Standards Section 2 Storm Drain requirements. The drainage area for the total project area is approximately 4.8 acres. In addition to the on-site improvements, the City of West Linn is requiring public utility and street improvements.

Water quality facilities used on property (see Storm Plans for location):

- *Planters*: A vegetated landscaped reservoir used to collect, filter, and infiltrate stormwater. The stormwater is treated as it percolates through the vegetation, growing medium, and gravel. Each has an open bottom, allowing for infiltration into the native soil to occur. It will have an overflow pipe that will discharge into the drywell system.
- *Piped Storm System*: The piped storm system consists of all underground pipes and structures that connect the roof drains, drywells, overflows, and rain gardens.
- *Rain Garden*: An engineered planter that filters pollutants out of stormwater as it passes through engineered growing medium prior to infiltration. The rain garden contains an overflow inlet structure that conveys excess stormwater from large rain events to public storm system and rip rap protection at inlets to prevent erosion and damage to the planter soil and vegetation.
- *Trapped Catch Basin*: A 24-inch square basin that collects stormwater runoff, traps debris, and conveys runoff into the stormwater system.
- *Overflow Inlet*: A vertical pipe with a grate over it that allows stormwater from large rain events to enter the downstream storm system. The grate prevents debris and rodents from entering the piped storm system.
- *Sedimentation Manhole*: A manhole with a sump to collect sediment and a down-turned elbow to prevent floatables from entering the piped system. This structure prevents debris and sediment from entering the drywell manholes.

## II. Schedule

Each part of the system shall be inspected and maintained quarterly within the first two years. After two years, all facilities should be inspected twice a year. All facilities should be inspected 48 hours after each major storm event. For this O&M Plan, a major storm event is defined as 1 inch of rain or more in 24 hours. All components of the storm system as described above must be inspected and maintained frequently or they will cease to function effectively. The facility owner shall keep a log, recording all inspection dates,

observations, and maintenance activities. Receipts shall be saved when maintenance is performed and there is record of expense.

### III. Inspection and Maintenance Procedures

The following items shall be inspected and maintained as stated:

#### Piped Storm System

- Sediment shall be removed biannually.
- Debris shall be removed from inlets and outlets quarterly.
- Quarterly inspection for clogging shall be performed.
- Grates shall be tamper proof.

Source Control measures prevent pollutants from mixing with stormwater. Typical non-structural control measures include raking and removing leaves, street sweeping, vacuum sweeping, and limited and controlled application of pesticides, herbicides, and fertilizers.

- Source control measures shall be inspected and maintained quarterly.
- Signage shall be maintained.

Spill Prevention measures shall be exercised when handling substances that can contaminate stormwater. Virtually all sites, including residential and commercial, present dangers from spills. It is important to exercise caution when handling substances that can contaminate stormwater. Activities that pose the chance of hazardous material spills shall not take place near collection facilities.

- The proper authority and the property owner shall be contacted immediately if a spill is observed.
- A spill kit shall be kept near spill-prone operations and refreshed annually.
- Employees shall be trained on spill control measures.
- Shut-off valves shall be tested quarterly.
- Releases of pollutants shall be corrected within 12 hours.

Insects and Rodents shall not be harbored in any part of the storm system.

- Pest control measures shall be taken when insects/rodents are found to be present. Standing water and food sources shall be prevented.
- If sprays are considered, a mosquito larvicide such as Bacillus thurendensis or Altoside formulations can be applied only if absolutely necessary and shall not be used where it will enter groundwater or come into contact with any standing water. Sprays shall be applied only by licensed individuals or contractors.
- Holes in the ground located in and around the storm system shall be filled.
- Outfalls draining into vegetated swales shall be inspected and cleaned regularly to ensure no rodent activity, which can clog or decrease the efficiency of the storm system.

Access shall be maintained for all facilities so operations and maintenance can be performed as regularly scheduled.

- Existing drywells shall be raised with a locking manhole cover to ensure access.

### IV. Financial Responsibilities

The facility is to be maintained by West Linn Wilsonville School District. The preparer has worked closely with personnel to design a system that can be easily maintained by maintenance staff.

The West Linn Wilsonville School District Facilities Manager is.

*A copy of the O&M Plan shall be provided to the property owner.*

# Appendix A

## Facilities Specifications

This page left blank for double-sided printing

## Simplified O&M Specifications BASINS

Maintenance Indicator	Corrective Action
<p><b>Structural Components</b>, including inlets and outlets/overflows, shall freely convey stormwater.</p>	
<ul style="list-style-type: none"> <li>➤ Clogged inlets or outlets</li> <li>➤ Broken inlets or outlets, including grates</li> <li>➤ Cracked or exposed drain pipes</li> <li>➤ Check dams</li> </ul>	<ul style="list-style-type: none"> <li>➤ Remove sediment and debris from catch basins, trench drains, curb inlets, and pipes to maintain at least 50% conveyance capacity at all times.</li> <li>➤ Repair or replace broken downspouts, curb cuts, standpipes, and screens as needed.</li> <li>➤ Repair/seal cracks. Replace when repair is insufficient. Cover with 6 inches of growing medium to prevent freeze/thaw and UV damage.</li> <li>➤ Maintain rock check dams per design standards.</li> </ul>
<p><b>Vegetation</b> shall cover 90% of the facility.</p>	
<ul style="list-style-type: none"> <li>➤ Dead or strained vegetation</li> <li>➤ Tall grass and vegetation</li> <li>➤ Weeds</li> </ul>	<ul style="list-style-type: none"> <li>➤ Replant per original planting plan, or substitute from <a href="#">Appendix F.4</a> plant list.</li> <li>➤ Irrigate as needed. Mulch banks as needed. <b>DO NOT</b> apply fertilizers, herbicides, or pesticides.</li> <li>➤ Prune to allow sight lines and foot traffic. Prune to ensure inlets and outlets freely convey stormwater into and/or out of the facility. Manually remove weeds. Remove all plant debris.</li> </ul>
<p><b>Growing/Filter Medium</b>, including soil and gravels, shall sustain healthy plant cover and infiltrate within 48 hours.</p>	
<ul style="list-style-type: none"> <li>➤ Erosion, and/or exposed soils</li> <li>➤ Scouring at inlet(s)</li> <li>➤ Slope slippage</li> <li>➤ Ponding</li> </ul>	<ul style="list-style-type: none"> <li>➤ Fill and lightly compact areas of erosion with City-approved soil mix. Stabilize soils with plantings from <a href="#">Appendix F.4</a>.</li> <li>➤ Replace splash pads at inlet(s) with gravel/rock.</li> <li>➤ Stabilize 3:1 slopes/banks with plantings from <a href="#">Appendix F.4</a>.</li> <li>➤ Remove the top 2-4 inches of sediment at the inlet. Add City-approved soil mix to match elevation of the inlet. Rake, till, or amend with City-approved soil mix to restore infiltration rate.</li> </ul>

**Maintenance Schedule:**

*Summer:* Make any structural repairs. Improve filter medium as needed. Clear drains and inlets. Irrigate as needed.

*Fall:* Replant exposed soil and replace dead plants. Remove sediment and plant debris.

*Winter:* Monitor infiltration/flow-through rates. Clear inlets and outlets/overflows to maintain conveyance.

*Spring:* Remove sediment and plant debris. Replant exposed soil and replace dead plants. Mulch as needed but do not block the inlets, outlets, or flow paths with mulch.

*All seasons:* Weed as necessary.

**Maintenance Records:**

*All maintenance operators are required to keep an annual inspection and maintenance log.*

Record the date, description, and contractor (if applicable) for all structural repairs, landscape maintenance, and facility cleanout activities. Keep work orders and invoices on file and make available upon request of the City inspector.

**Access:** Maintain ingress/egress, including access roads, to design standards.

**Infiltration/Flow Control:** All facilities shall drain within 48 hours. Record the time/date, weather, and site



conditions when ponding occurs.

**Pollution Prevention:** All sites shall implement BMPs to prevent hazardous or solid wastes or excessive oil and sediment from contaminating stormwater. Contact Spill Prevention & Citizen Response at 503-823-7180 for immediate assistance responding to spills. Record the time/date, weather, and site conditions if site activities contaminate stormwater. Record the time/date and description of corrective action taken.

**Vectors (Mosquitoes and Rodents):** Stormwater facilities shall not harbor mosquito larvae or rats that pose a threat to public health or that undermine the facility structure. Monitor standing water for small wiggling sticks perpendicular to the water's surface. Note holes/burrows in and around facilities. Call Multnomah County Vector Control at 503-988-3464 for immediate assistance to eradicate vectors. Record the time/date, weather, and site conditions when vector activity is observed.

# Appendix B

## Inspection Log

This page left blank for double-sided printing

**SUNSET PRIMARY SCHOOL**  
**Inspection and Maintenance Log**

<u>Date</u>	<u>Facility</u>	<u>Performed by</u>	<u>Work performed</u>	<u>Details</u>

# SUNSET REVISIONING

West Linn - Wilsonville School District  
2351 Oxford St, West Linn, OR 97068

**owner**  
West Linn - Wilsonville School District  
22210 SW Stafford Road  
Tualatin, Oregon 97062  
t: (503) 673-7988 f: (503) 673-7001

**architect**  
Dull Olson Weekes - IBI Group Architects Inc.  
907 SW Stark Street  
Portland, Oregon 97205  
t: (503) 226-6950 f: (503) 273-9192

**project manager**  
Heery International  
2755 SW Borland Road  
Tualatin, Oregon 97062  
t: (503) 220-5992

**civil engineer**  
KPF Consulting Engineers  
111 SW Fifth Avenue #2500  
Portland, Oregon 97204  
t: (503) 227-3251

**landscape architect**  
Walker-Macy Landscape Architects  
111 SW Oak Street, Suite #200  
Portland, Oregon 97204  
t: (503) 228-3122 f: (503) 273-8878

**food service**  
Halliday Associates  
656 NW Norwood Street  
Camas, Washington 98607  
t: (360) 834-6657 f: (360) 834-5453

**structural engineer**  
Froelich Consulting Engineers  
6969 SW Hampton Street  
Tigard, Oregon 97223  
t: (503) 624-7005 f: (503) 624-9770

**mechanical engineer**  
PAE Consulting Engineers  
522 SW 5th Avenue #1500  
Portland, Oregon 97204  
t: (503) 226-2921 f: (503) 226-2930

**electrical engineer**  
PAE Consulting Engineers  
522 SW 5th Avenue #1500  
Portland, Oregon 97204  
t: (503) 226-2921 f: (503) 226-2930

**technology engineer**  
Interface Engineering Inc.  
708 SW 3rd Avenue, Suite #400  
Portland, Oregon 97204  
t: (503) 382-2683 f: (503) 382-2262

**sound system engineer**  
BRC Acoustics & Audiovisual Design  
1932 1st Avenue, Suite #303  
Seattle, Washington 98101  
t: (206) 270-8910

## CONTENTS

### land use

LU1.00	SITE ANALYSIS MAP & SITE CIRCULATION
LU1.01	EXISTING CONDITIONS
LU1.02	SITE PLAN
LU1.03	GRADING PLAN
LU1.04	UTILITY PLAN
LU1.05	STORM PLAN
LU1.06	OXFORD & PARK ROW PLAN
LU1.07	BITTNER ROW PLAN
LU1.08	SLOPE ANALYSIS
LU2.01	TREE REMOVAL PLAN
LU2.02	LANDSCAPE PLAN
LU2.03	LANDSCAPE PLANTING PLAN
LU3.01	MAIN FLOOR PLAN
LU3.02	SECOND FLOOR PLAN
LU3.03	EXTERIOR ELEVATIONS
LU3.04	BUILDING SECTIONS & SIGN
LU3.05	EXTERIOR MATERIALS
LU4.01	LIGHT COVERAGE PLAN
LU4.02	PGE STREET LIGHTING PLAN
IL - 1	ILLUMINATION PLAN

## VICINITY MAP



## LAND USE

Revised: January 8, 2016

**SUNSET REVISIONING**  
LAND USE

November 13, 2015 | Project # 15015  
Revised: January 8, 2016

8/17/2015 8:49:42 AM  
 N:\c\2015\15087-Sunset-Primary-School\FILE-TRANS\IN\20150810-REV115-08-10 WLWV ARMS.rvt

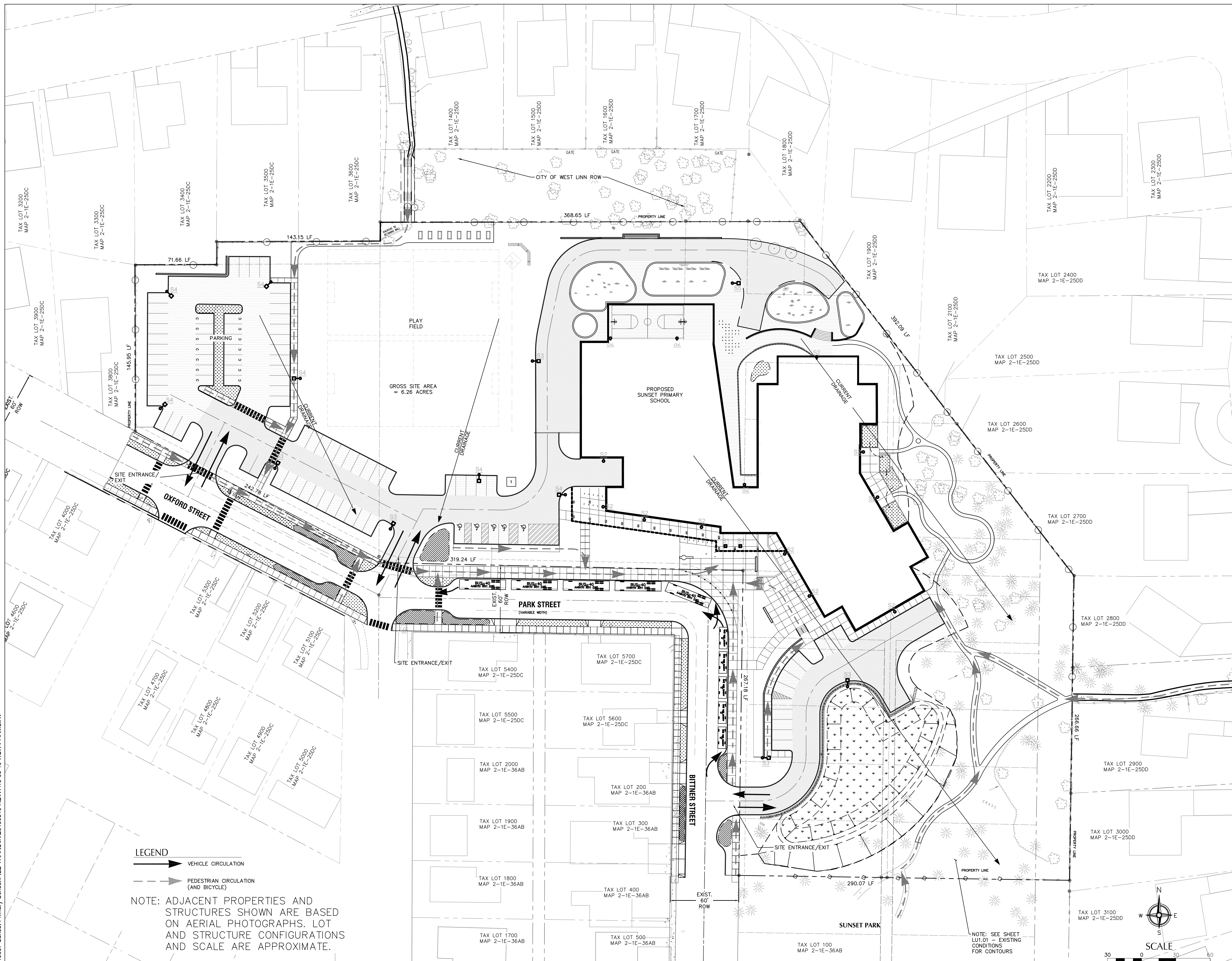

**WEST LINN WILSONVILLE**  
 2755 SW Borland Road  
 Tualatin, OR 97062  
 (503) 673 7995

**dowa | IBI**

**Dull Olson Weekes - IBI Group Architects, Inc.**

907 SW Stark Street Portland, OR 97205 USA  
 tel 503 226 6950 fax 503 273 9192  
 www.dowa-ibigroup.com www.dowagroup.com

**kpff**

111 SW Fifth Ave., Suite 2500  
 Portland, OR 97204  
 O: 503.227.3251  
 F: 503.274.4661  
 www.kpff.com

**PRELIMINARY NOT FOR CONSTRUCTION**

**SUNSET REVISIONING**  
**West Linn Wilsonville**  
 2351 Oxford St, West Linn, OR 97068  
 t: (503) 673-7988

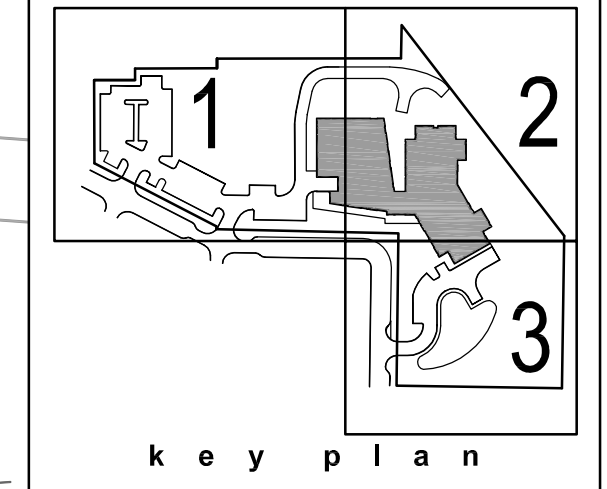

phase	LAND USE
date	JANUARY 8, 2016
revisions	
project #	15015
<b>SITE ANALYSIS MAP &amp; SITE CIRCULATION</b>	
<b>LU1.00</b>	

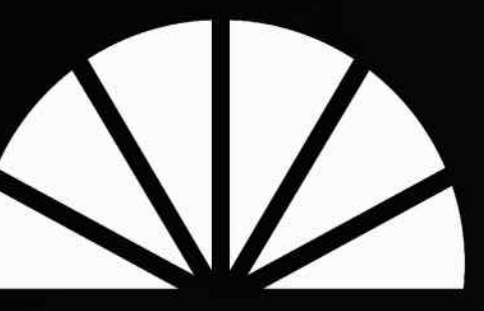

WEST LINN WILSONVILLE

2755 SW Borland Road  
Tualatin, OR 97062  
(503) 673-7995



Dull Olson Weekes - IBI Group  
Architects, Inc.

907 SW Stark Street Portland OR 97205 USA  
tel 503 226 6950 fax 503 273 9192  
www.dowolgroup.com www.ibigroup.com

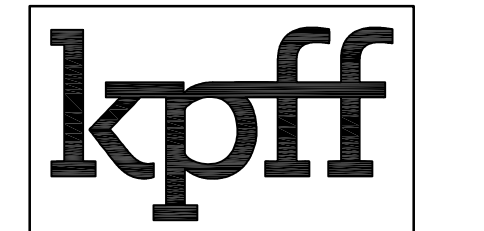

111 SW Fifth Ave., Suite 2500  
Portland, OR 97204  
O: 503.227.4351  
F: 503.274.4683  
www.kpff.com

PRELIMINARY  
NOT FOR  
CONSTRUCTION

SUNSET REVISIONING  
West Linn Wilsonville  
2351 Oxford St, West Linn, OR 97068  
t: (503) 673-7988

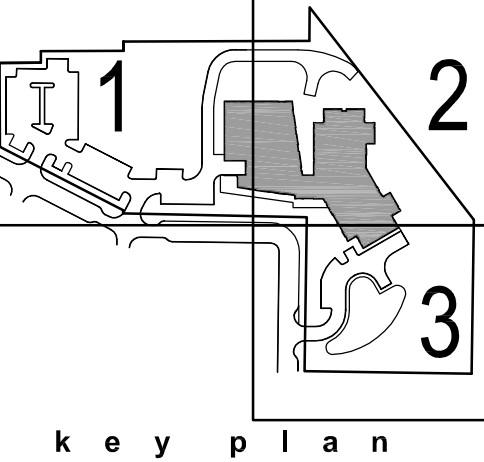

phase	LAND USE
date	JANUARY 8, 2016
revisions	
project #	15015
EXISTING CONDITIONS	

LU1.01

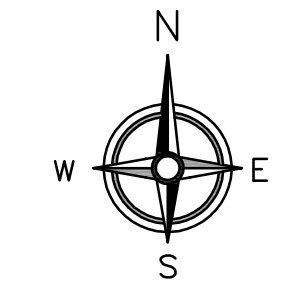

SCALE 1 INCH = 30 FEET  
30 0 30 60

**Legend:**

- FIRE HYDRANT
- WATER METER
- WATER VALVE
- SIGN
- FOUND MONUMENT
- GAS LINE
- OVERHEAD PHONE LINE
- OVERHEAD POWER LINE
- SANITARY SEWER LINE
- STORM SEWER LINE
- WATER LINE
- EDGE OF PAVEMENT

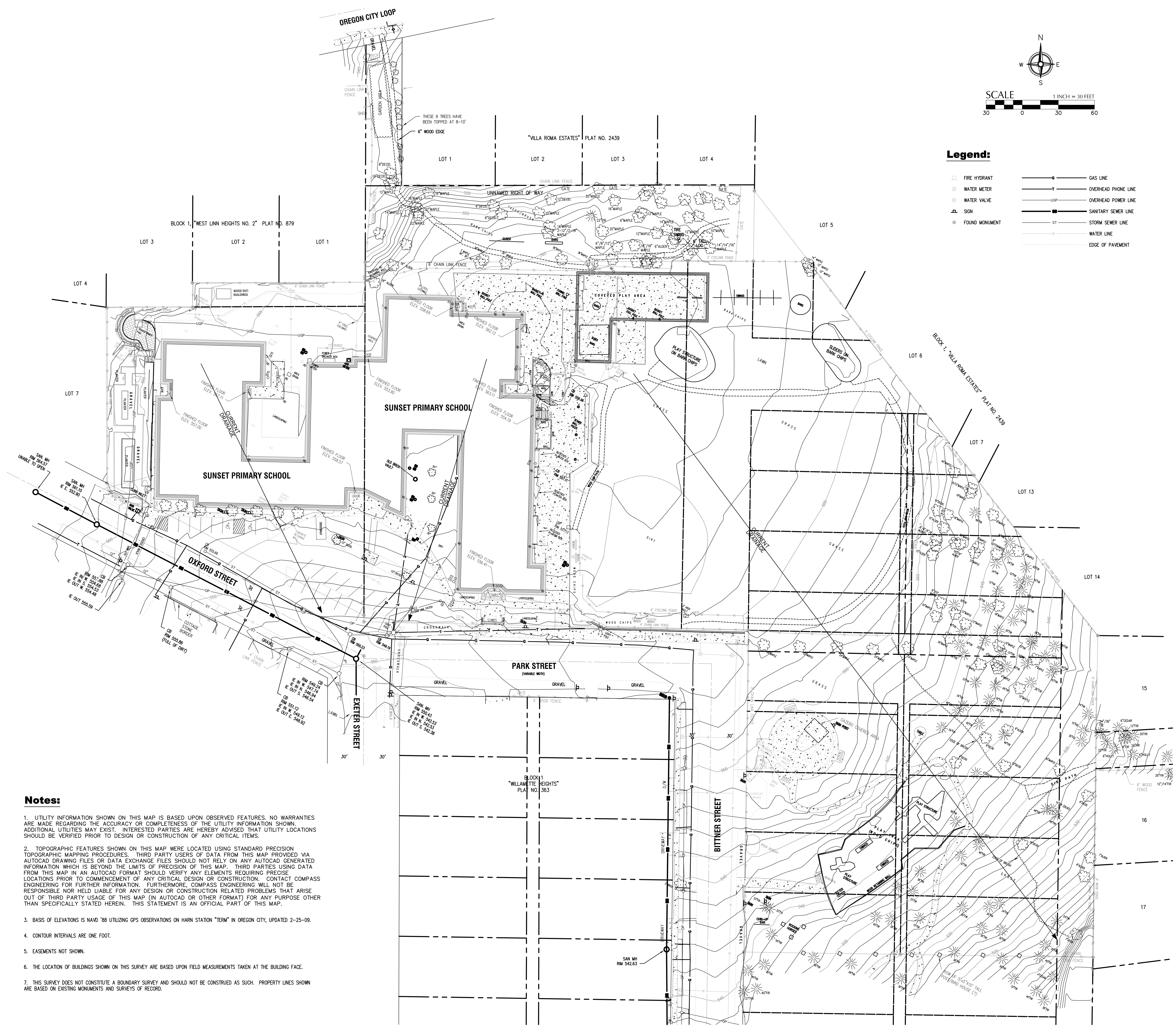

**Notes:**

- UTILITY INFORMATION SHOWN ON THIS MAP IS BASED UPON OBSERVED FEATURES. NO WARRANTIES ARE MADE REGARDING THE ACCURACY OR COMPLETENESS OF THE UTILITY INFORMATION SHOWN. ADDITIONAL UTILITIES MAY EXIST. INTERESTED PARTIES ARE HEREBY ADVISED THAT UTILITY LOCATIONS SHOULD BE VERIFIED PRIOR TO DESIGN OR CONSTRUCTION OF ANY CRITICAL ITEMS.
- TOPOGRAPHIC FEATURES SHOWN ON THIS MAP WERE LOCATED USING STANDARD PRECISION TOPOGRAPHIC MAPPING PROCEDURES. THIRD PARTY USERS OF DATA FROM THIS MAP PROVIDED VIA AUTOCAD DRAWING FILES OR DATA EXCHANGE FILES SHOULD NOT RELY ON ANY AUTOCAD GENERATED INFORMATION WHICH IS BEYOND THE LIMITS OF PRECISION OF THIS MAP. THIRD PARTIES USING DATA FROM THIS MAP IN AN AUTOCAD FORMAT SHOULD VERIFY ANY ELEMENTS REQUIRING PRECISE LOCATIONS PRIOR TO COMMENCEMENT OF ANY CRITICAL DESIGN OR CONSTRUCTION. CONTACT COMPASS ENGINEERING FOR FURTHER INFORMATION. FURTHERMORE, COMPASS ENGINEERING WILL NOT BE RESPONSIBLE NOR HELD LIABLE FOR ANY DESIGN OR CONSTRUCTION RELATED PROBLEMS THAT ARISE OUT OF THIRD PARTY USAGE OF THIS MAP (IN AUTOCAD OR OTHER FORMAT) FOR ANY PURPOSE OTHER THAN SPECIFICALLY STATED HEREIN. THIS STATEMENT IS AN OFFICIAL PART OF THIS MAP.
- BASIS OF ELEVATIONS IS NAVD '88 UTILIZING GPS OBSERVATIONS ON HARN STATION "TERM" IN OREGON CITY, UPDATED 2-25-09.
- CONTOUR INTERVALS ARE ONE FOOT.
- EASEMENTS NOT SHOWN.
- THE LOCATION OF BUILDINGS SHOWN ON THIS SURVEY ARE BASED UPON FIELD MEASUREMENTS TAKEN AT THE BUILDING FACE.
- THIS SURVEY DOES NOT CONSTITUTE A BOUNDARY SURVEY AND SHOULD NOT BE CONSTRUED AS SUCH. PROPERTY LINES SHOWN ARE BASED ON EXISTING MONUMENTS AND SURVEYS OF RECORD.

8/17/2015 8:15:12 AM N:\c\p\20150315087-Sunset-Primary-School\FILE-TRANS\IN\20150810-REV\15-08-10 WL\WV.ARM.S.rvt

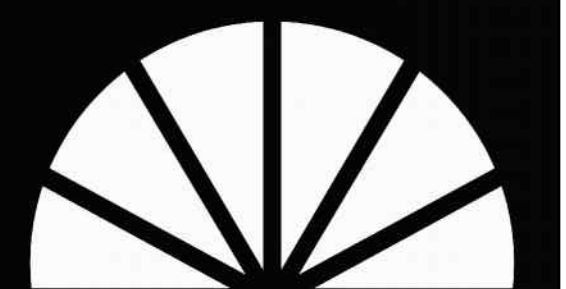

WEST LINN WILSONVILLE  
 2755 SW Borland Road  
 Tualatin, OR 97062  
 (503) 673 7995



Dull Olson Weekes - IBI Group  
 Architects, Inc.

907 SW Stark Street Portland, OR 97205 USA  
 tel 503 226 6950 fax 503 273 9192  
 www.dowa-ibigroup.com www.ibigroup.com

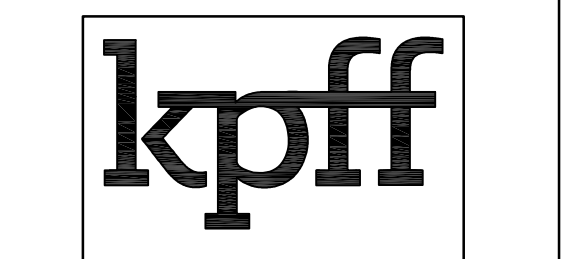

111 SW Fifth Ave., Suite 2500  
 Portland, OR 97204  
 O: 503.227.3253  
 F: 503.274.4661  
 www.kpff.com

PRELIMINARY  
 NOT FOR  
 CONSTRUCTION

SUNSET REVISIONING  
 West Linn Wilsonville  
 2351 Oxford St, West Linn, OR 97068  
 t: (503) 673-7988

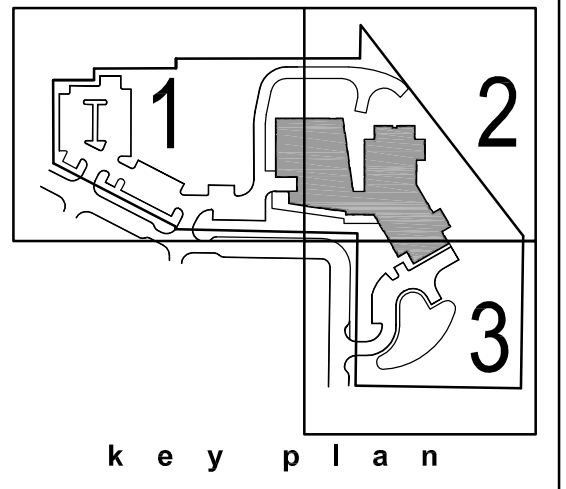

phase	LAND USE
date	JANUARY 8, 2016
revisions	
project #	15015
SITE PLAN	

**LU1.02**

**LEGEND**

	PROPOSED ASPHALT PAVEMENT
	PROPOSED HEAVY ASPHALT PAVEMENT
	PROPOSED HEAVY CONCRETE PAVEMENT
	PROPOSED CONCRETE SIDEWALK
	PROPOSED STREET RUNOFF PLANTER

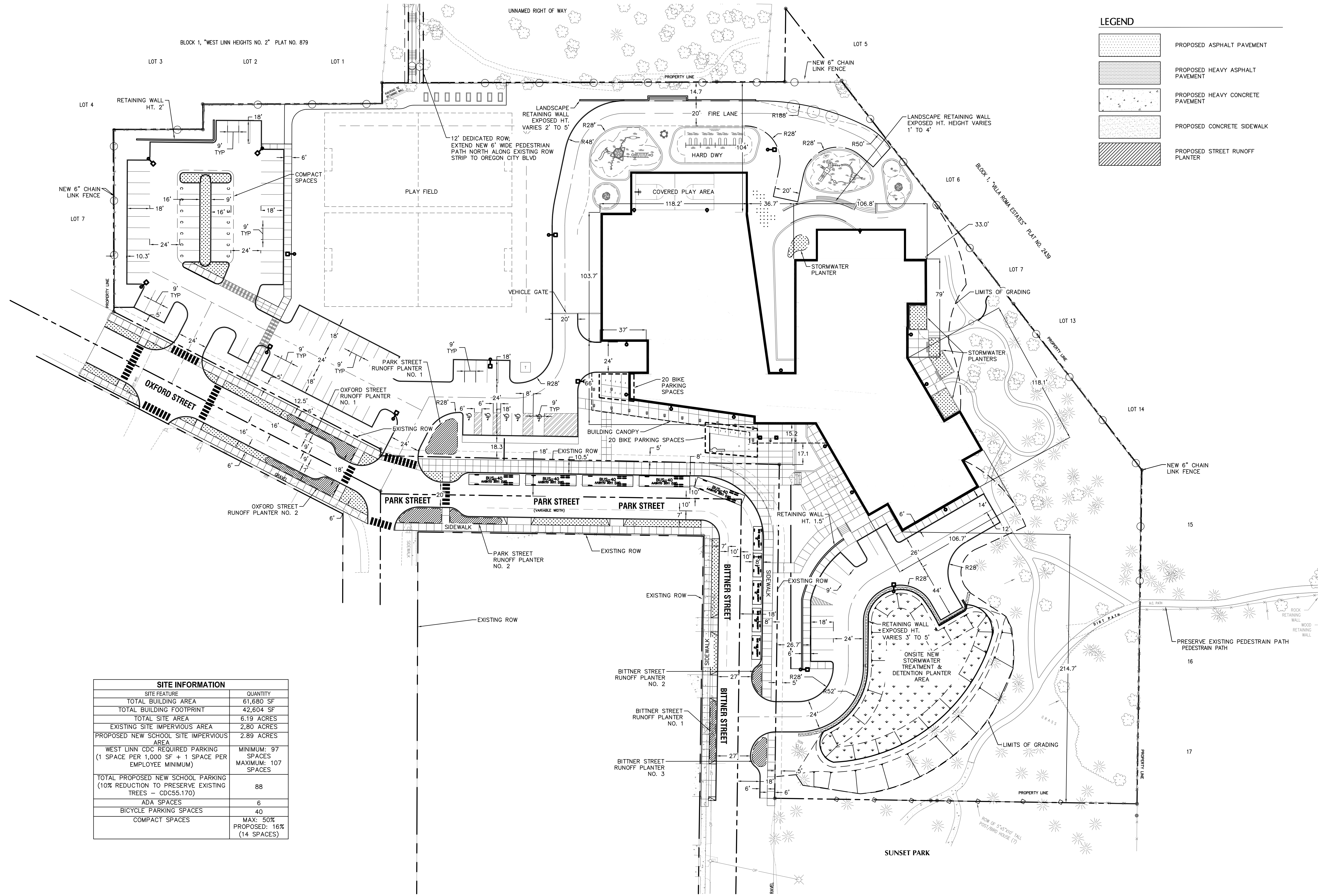

**SITE INFORMATION**

SITE FEATURE	QUANTITY
TOTAL BUILDING AREA	61,680 SF
TOTAL BUILDING FOOTPRINT	42,604 SF
TOTAL SITE AREA	6.19 ACRES
EXISTING SITE IMPERVIOUS AREA	2.80 ACRES
PROPOSED NEW SCHOOL SITE IMPERVIOUS AREA	2.89 ACRES
WEST LINN CDC REQUIRED PARKING (1 SPACE PER 1,000 SF + 1 SPACE PER EMPLOYEE MINIMUM)	MINIMUM: 97 SPACES MAXIMUM: 107 SPACES
TOTAL PROPOSED NEW SCHOOL PARKING (10% REDUCTION TO PRESERVE EXISTING TREES - CDC55.170)	88
ADA SPACES	6
BICYCLE PARKING SPACES	40
COMPACT SPACES	MAX: 50% PROPOSED: 16% (14 SPACES)

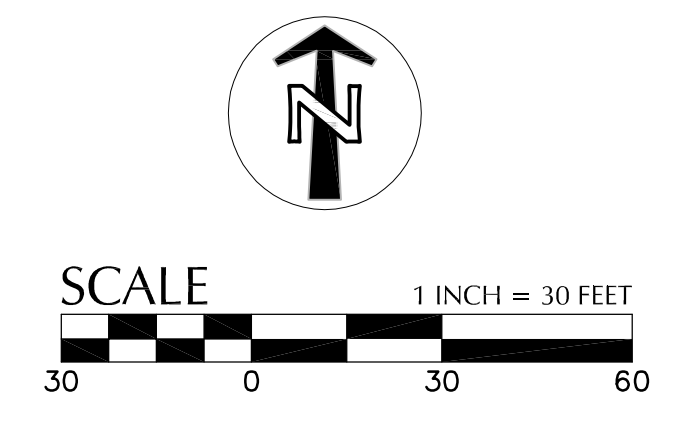



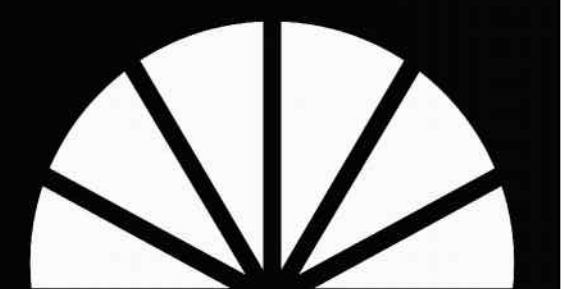

WEST LINN WILSONVILLE  
 2755 SW Borland Road  
 Tualatin, OR 97062  
 (503) 673 7995



Dull Olson Weekes - IBI Group  
 Architects, Inc.

907 SW Stark Street Portland OR 97205 USA  
 tel 503 226 6950 fax 503 273 9192  
 www.dowa-ibigroup.com www.ibigroup.com

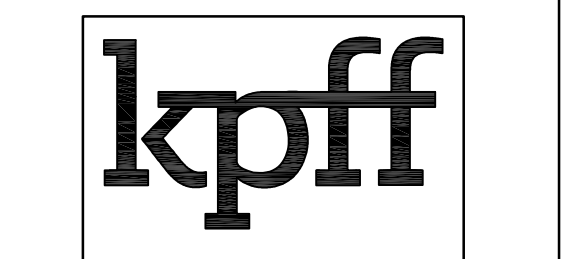

111 SW Fifth Ave., Suite 2900  
 Portland, OR 97204  
 O: 503.227.3253  
 F: 503.274.4661  
 www.kpff.com

PRELIMINARY  
 NOT FOR  
 CONSTRUCTION

SUNSET REVISIONING  
 West Linn Wilsonville  
 2351 Oxford St. West Linn, OR 97068  
 t: (503) 673-7988

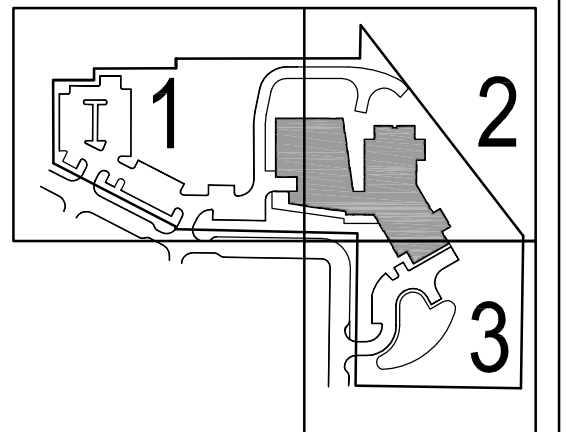

key plan

phase	LAND USE
date	JANUARY 8, 2016
revisions	
project #	15015
GRADING PLAN	

**LU1.03**

**GRADING LEGEND**

CALLOUT	DESCRIPTION
X.X%	GRADING SLOPE AND DIRECTION (DOWNHILL)
XX.XX	SPOT ELEVATION
XX	DESCRIPTION LISTED BELOW, NO DESCRIPTION MEANS TP OR TG
BOS	BOTTOM OF SWALE
BOW	BACK OF WALK
BW	BOTTOM OF WALL
EG	EXISTING GRADE
FG	FINISHED GRADE
FL	FLOW LINE
G	GUTTER
HP	HIGH POINT
LP	LOW POINT
RIM	RIM OF STRUCTURE
TC	TOP OF CURB
TP	TOP OF PAVEMENT
TW	TOP WALL

**EROSION CONTROL LEGEND**

	SILT FENCE
	COMPOST BLANKET
	STRAW WATTLE

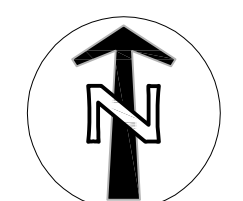
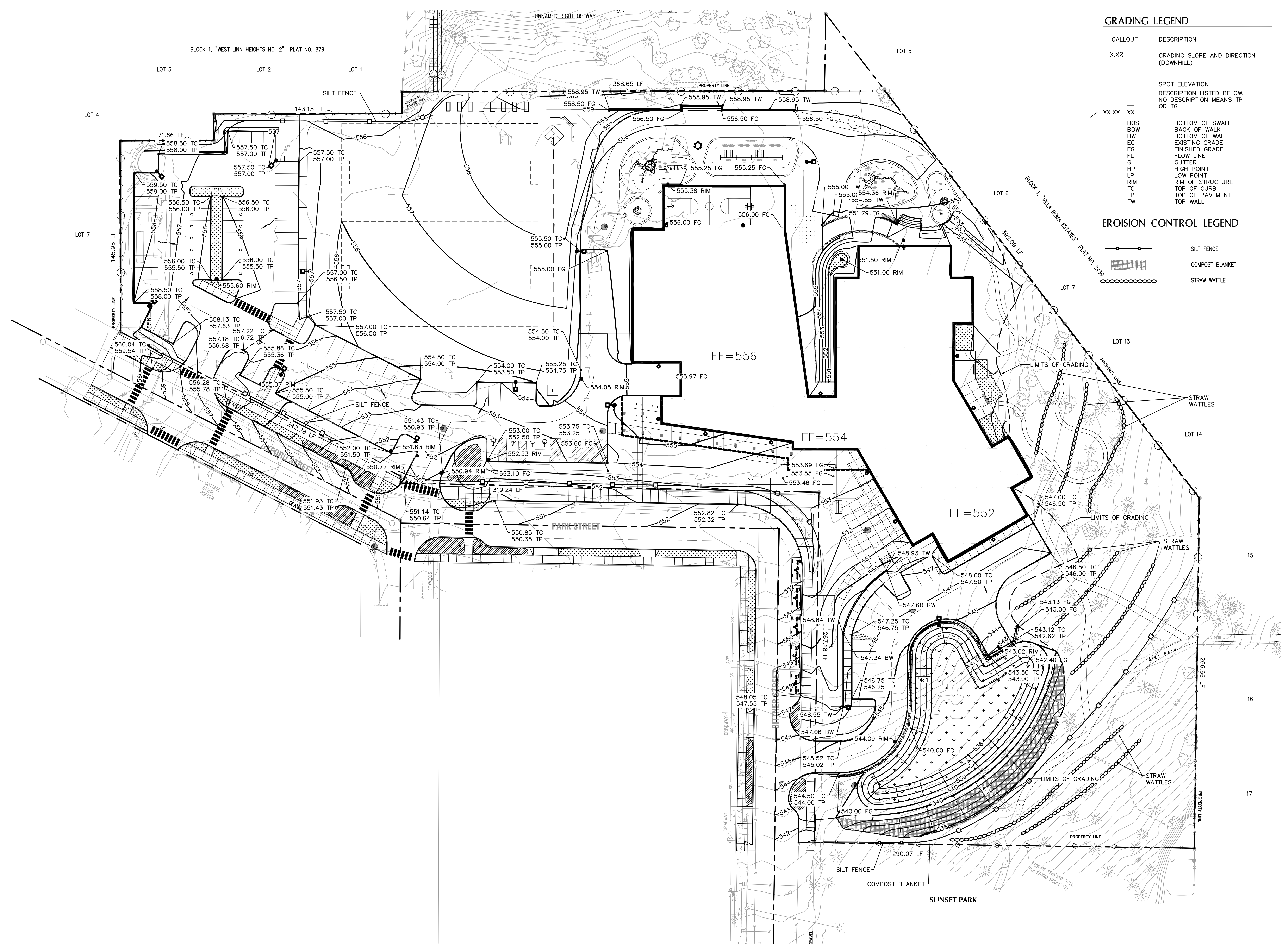

SCALE 1 INCH = 30 FEET  
 30 0 30 60

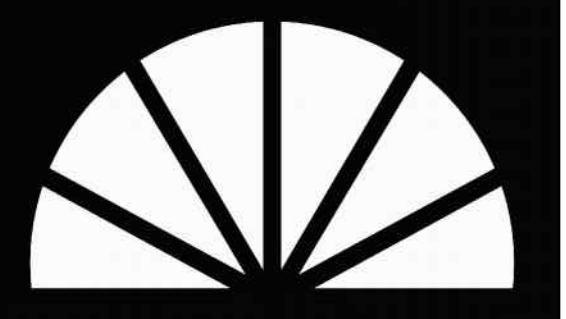

WEST LINN WILSONVILLE  
 2755 SW Borland Road  
 Tualatin, OR 97062  
 (503) 673 7995



Dull Olson Weekes - IBI Group  
 Architects, Inc.

907 SW Stark Street Portland, OR 97205 USA  
 tel 503 226 6950 fax 503 273 9192  
 www.dowa-ibigroup.com www.ibigroup.com



111 SW Fifth Ave., Suite 2500  
 Portland, OR 97204  
 O: 503.227.3253  
 F: 503.274.4661  
 www.kpff.com

PRELIMINARY  
 NOT FOR  
 CONSTRUCTION

SUNSET REVISIONING  
 West Linn Wilsonville  
 2351 Oxford St, West Linn, OR 97068  
 t: (503) 673-7988

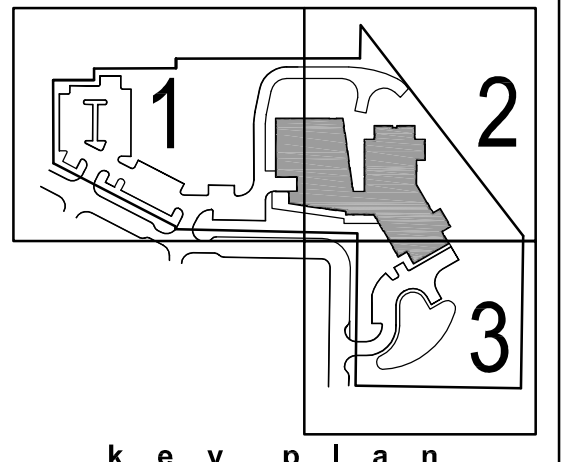

phase	LAND USE
date	JANUARY 8, 2016
revisions	
project #	15015
UTILITY PLAN	

LU1.04

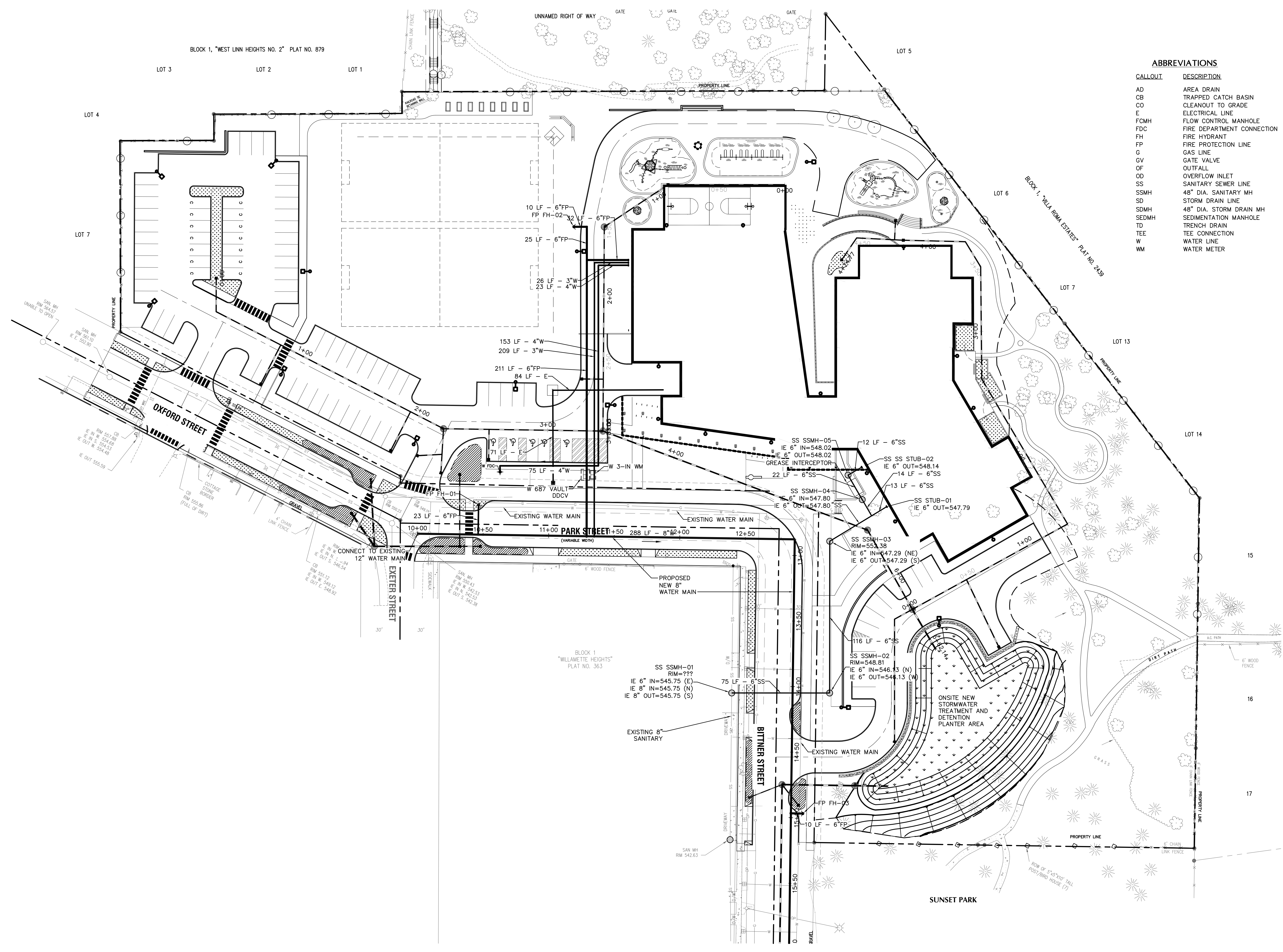

ABBREVIATIONS

CALLOUT	DESCRIPTION
AD	AREA DRAIN
CB	TRAPPED CATCH BASIN
CO	CLEANOUT TO GRADE
E	ELECTRICAL LINE
FCMH	FLOW CONTROL MANHOLE
FDC	FIRE DEPARTMENT CONNECTION
FH	FIRE HYDRANT
FP	FIRE PROTECTION LINE
G	GAS LINE
GV	GATE VALVE
OF	OUTFALL
OI	OVERFLOW INLET
OS	SANITARY SEWER LINE
SSMH	48" DIA. SANITARY MH
SD	STORM DRAIN LINE
SDMH	48" DIA. STORM DRAIN MH
SEDMH	SEDIMENTATION MANHOLE
TD	TRENCH DRAIN
TEE	TEE CONNECTION
W	WATER LINE
WM	WATER METER

PIPE LEGEND

PROPOSED	EXISTING

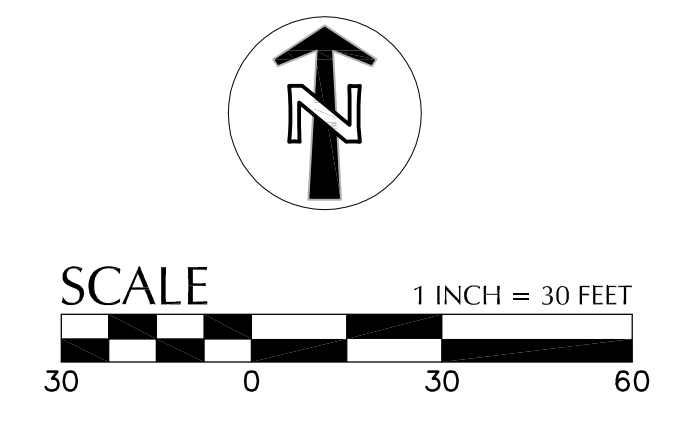

8/17/2015 8:49:12 AM  
 N:\c\p\2015\15015\15015-Sunset-Primary-School-TRANS\IN\20150810-REV\15-08-10 WL\WV ARMS.rvt

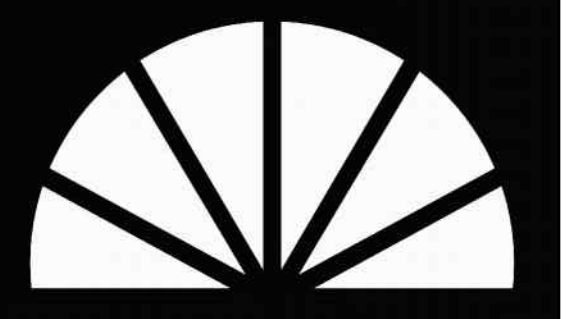

WEST LINN WILSONVILLE  
 2755 SW Borland Road  
 Tualatin, OR 97062  
 (503) 673 7995



Dull Olson Weekes - IBI Group  
 Architects, Inc.

907 SW Stark Street Portland, OR 97205 USA  
 tel 503 226 6950 fax 503 273 9192  
 www.dowa-ibigroup.com www.ibigroup.com

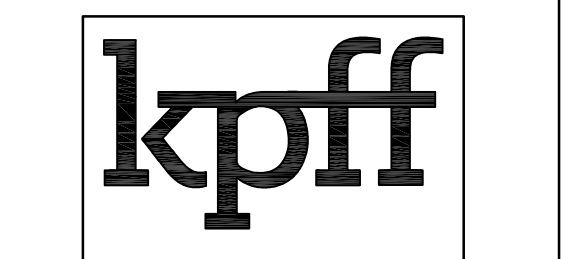

111 SW Fifth Ave., Suite 2500  
 Portland, OR 97204  
 O: 503.277.3253  
 F: 503.274.4661  
 www.kpff.com

PRELIMINARY  
 NOT FOR  
 CONSTRUCTION

SUNSET REVISIONING  
 West Linn Wilsonville  
 2351 Oxford St, West Linn, OR 97068  
 t: (503) 673-7988

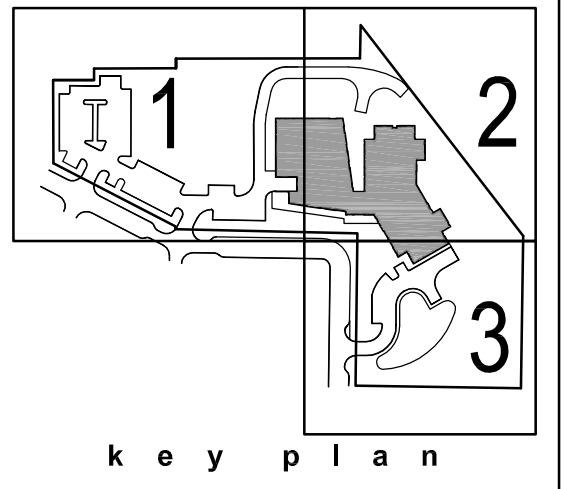

phase	LAND USE
date	JANUARY 8, 2016
revisions	
project #	15015
	STORM PLAN

**LU1.05**

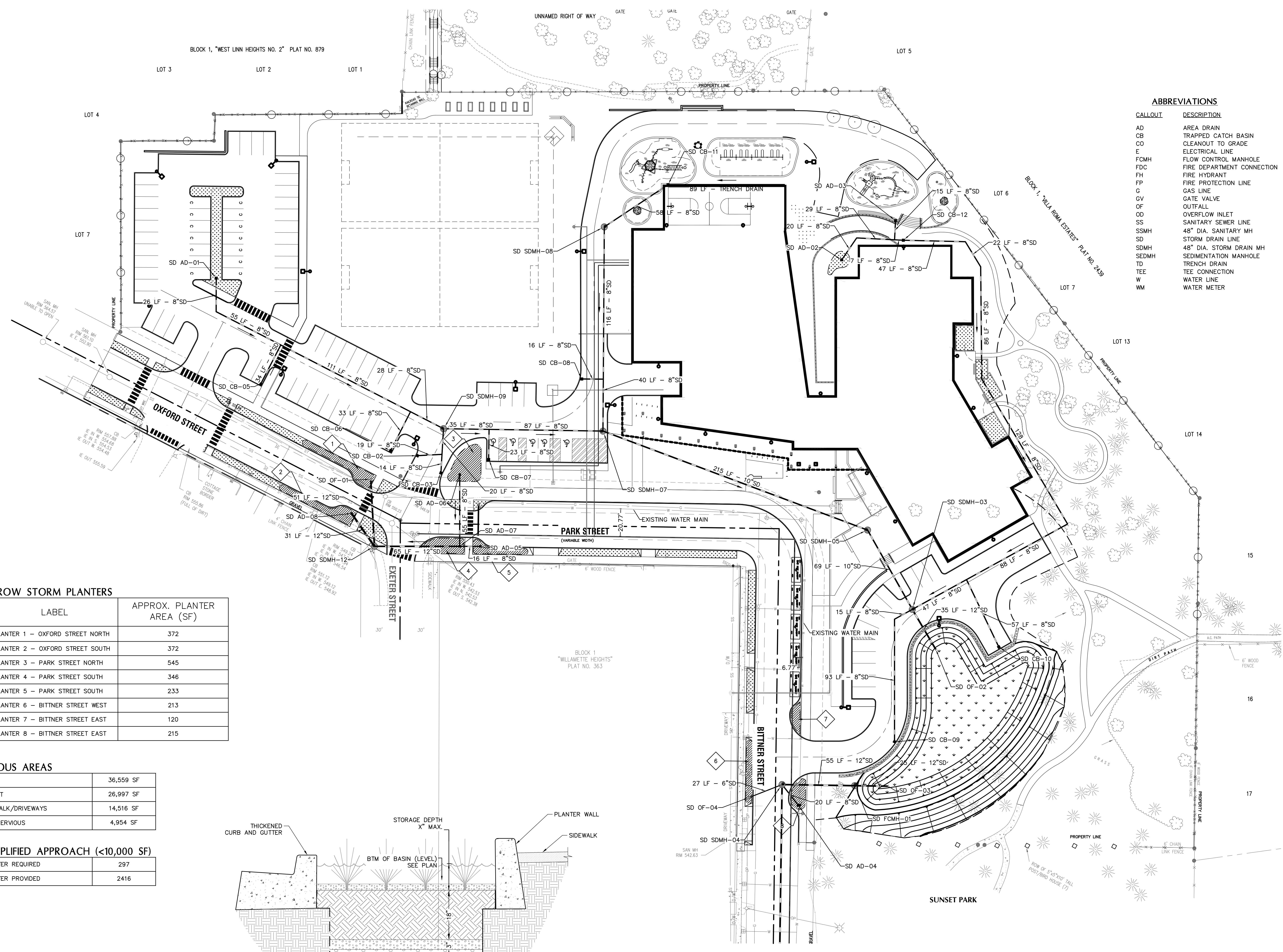

**ABBREVIATIONS**

CALLOUT	DESCRIPTION
AD	AREA DRAIN
CB	TRAPPED CATCH BASIN
CO	CLEANOUT TO GRADE
E	ELECTRICAL LINE
FCMH	FLOW CONTROL MANHOLE
FDC	FIRE DEPARTMENT CONNECTION
FH	FIRE HYDRANT
FP	FIRE PROTECTION LINE
G	GAS LINE
GV	GATE VALVE
OF	OUTFALL
OD	OVERFLOW INLET
SS	SANITARY SEWER LINE
SSMH	48" DIA. SANITARY MH
SD	STORM DRAIN LINE
SDM	48" DIA. STORM DRAIN MH
SDMH	SEDIMENTATION MANHOLE
TD	TRENCH DRAIN
TEE	TEE CONNECTION
W	WATER LINE
WM	WATER METER

**PUBLIC ROW STORM PLANTERS**

xx	LABEL	APPROX. PLANTER AREA (SF)
1	PLANTER 1 - OXFORD STREET NORTH	372
2	PLANTER 2 - OXFORD STREET SOUTH	372
3	PLANTER 3 - PARK STREET NORTH	545
4	PLANTER 4 - PARK STREET SOUTH	346
5	PLANTER 5 - PARK STREET SOUTH	233
6	PLANTER 6 - BITTNER STREET WEST	213
7	PLANTER 7 - BITTNER STREET EAST	120
8	PLANTER 8 - BITTNER STREET EAST	215

**IMPERVIOUS AREAS**

EX. ROW	36,559 SF
PROP. STREET	26,997 SF
PROP. SIDEWALK/DRIVEWAYS	14,516 SF
NET NEW IMPERVIOUS	4,954 SF

**PDX SIMPLIFIED APPROACH (<10,000 SF)**

SF OF PLANTER REQUIRED	297
SF OF PLANTER PROVIDED	2416

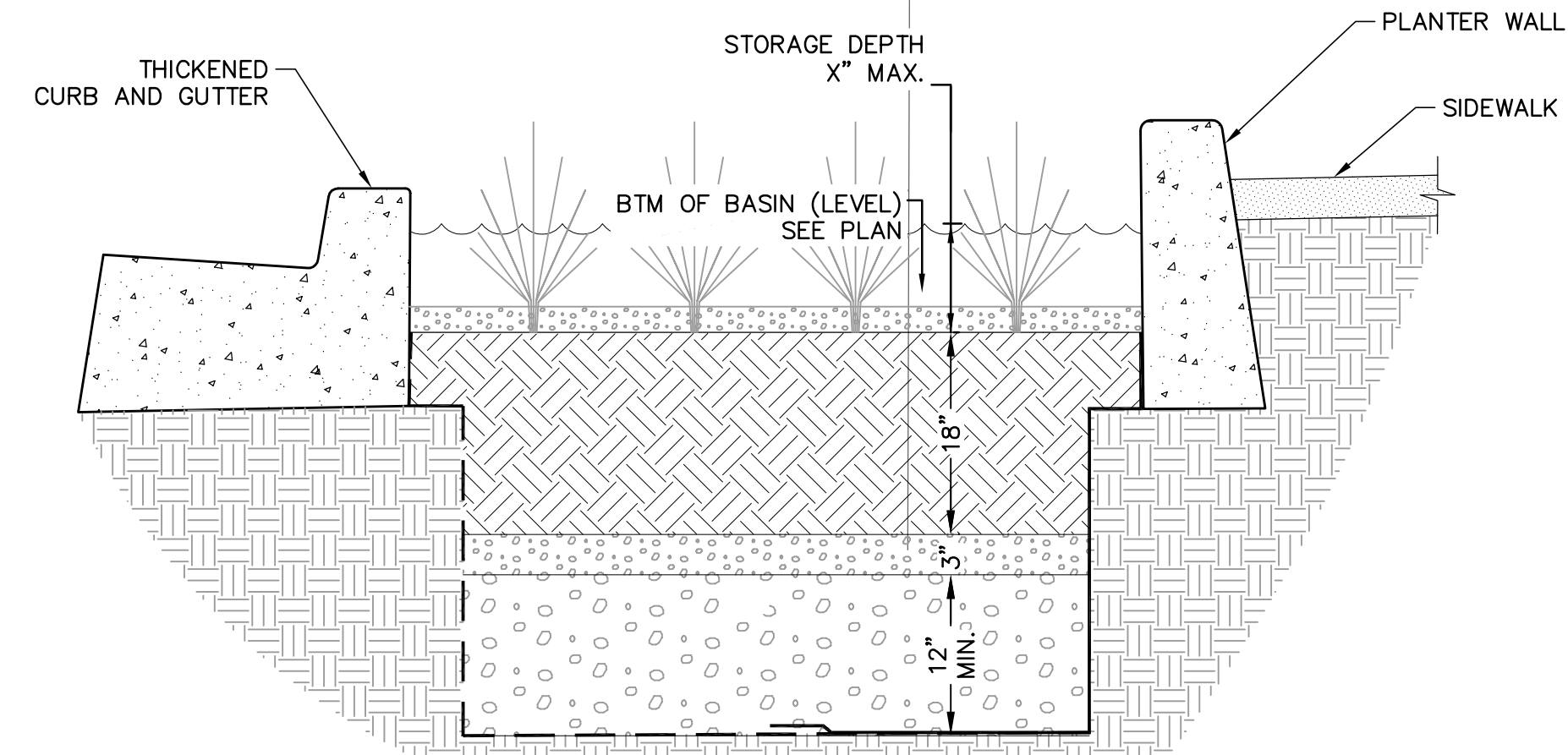

**PIPE LEGEND**

PROPOSED	EXISTING

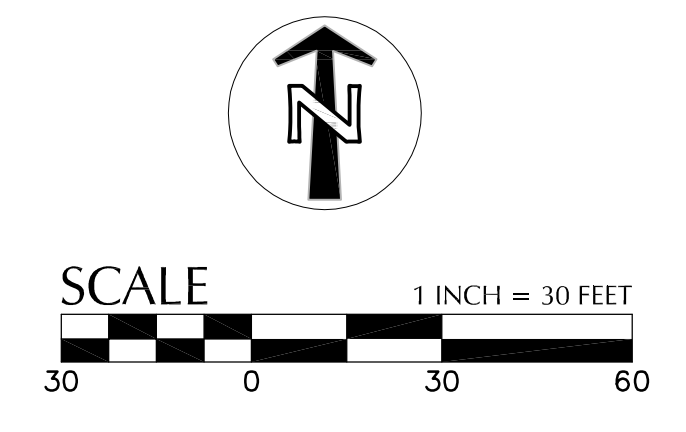

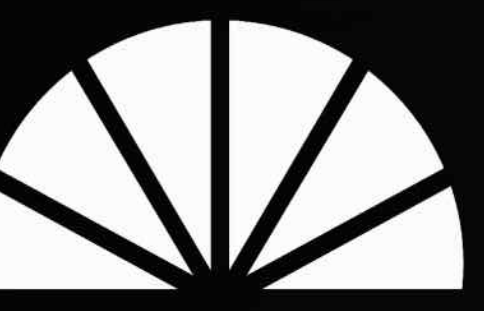

WEST LINN WILSONVILLE

2755 SW Borland Road  
Tualatin, OR 97062  
(503) 673 7995



Dull Olson Weekes - IBI Group  
Architects, Inc.

907 SW Stark Street Portland OR 97205 USA  
tel 503 226 6950 fax 503 273 9192  
www.dowa-ibigroup.com www.ibigroup.com



PRELIMINARY  
NOT FOR  
CONSTRUCTION

SUNSET REVISIONING  
West Linn Wilsonville  
2351 Oxford St, West Linn, OR 97068  
t: (503) 673-7988

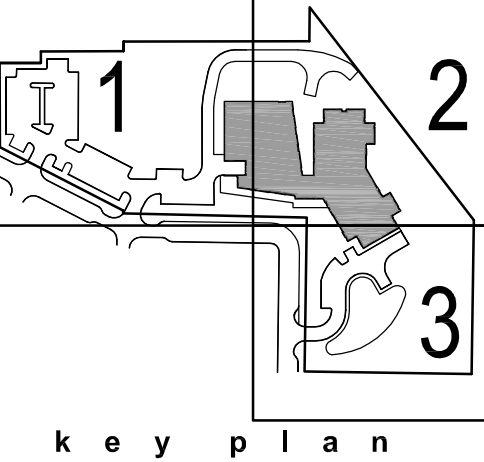

phase	LAND USE
date	JANUARY 8, 2016
revisions	
project #	15015

OXFORD & PARK ROW PLAN

**LU1.06**

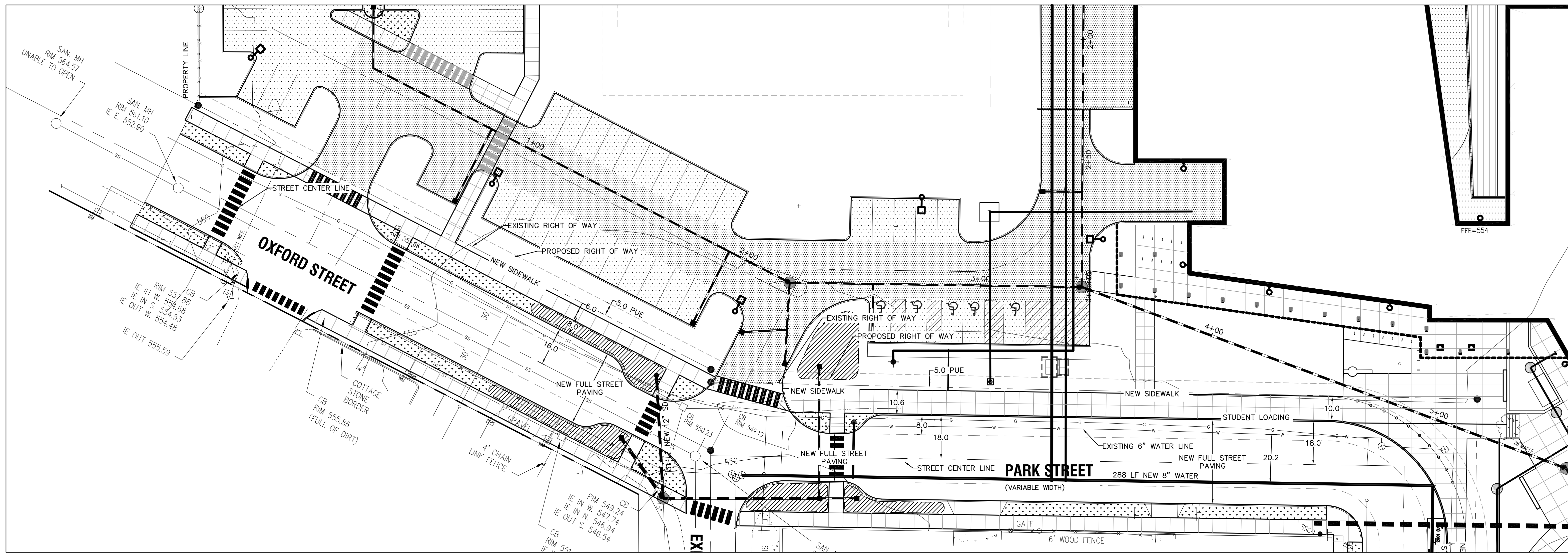

### OXFORD AND PARK STREET ROW PLAN

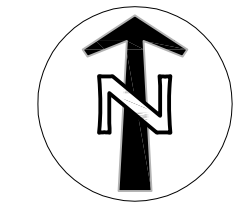

SCALE 1 INCH = 20 FEET  
0 20 40

8/17/2015 8:19:12 AM  
N:\c\20150315087-Sunset-Primary-School\FILE-TRANS\IN\20150810-REV\15-08-10 WL\WV ARMS.rvt

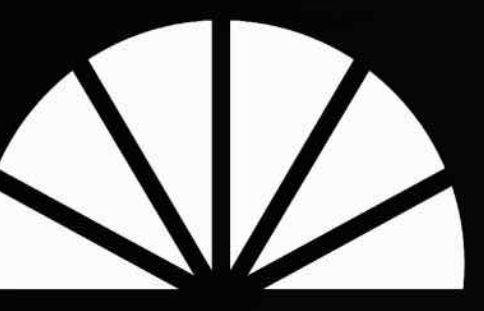

WEST LINN WILSONVILLE  
 2755 SW Borland Road  
 Tualatin, OR 97062  
 (503) 673 7995



Dull Olson Weekes - IBI Group  
 Architects, Inc.

907 SW Stark Street Portland, OR 97205 USA  
 tel 503 226 6950 fax 503 273 9192  
 www.dowa-ibigroup.com www.ibigroup.com

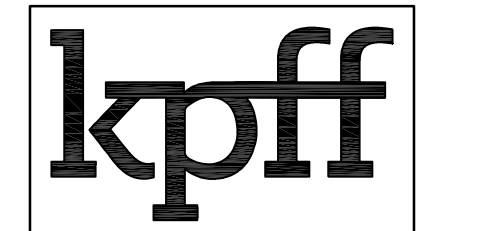

111 SW Fifth Ave., Suite 2500  
 Portland, OR 97204  
 O: 503.227.4351  
 F: 503.274.4663  
 www.kpff.com

PRELIMINARY  
 NOT FOR  
 CONSTRUCTION

SUNSET REVISIONING  
 West Linn Wilsonville  
 2351 Oxford St, West Linn, OR 97068  
 t: (503) 673-7988

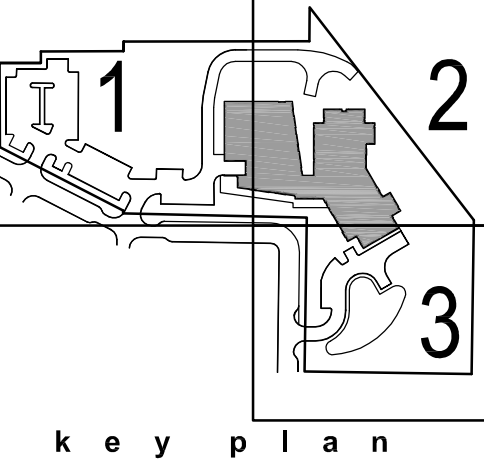

phase | LAND USE

date | JANUARY 8, 2016

revisions

project # | 15015

BITTNER ROW PLAN

**LU1.07**

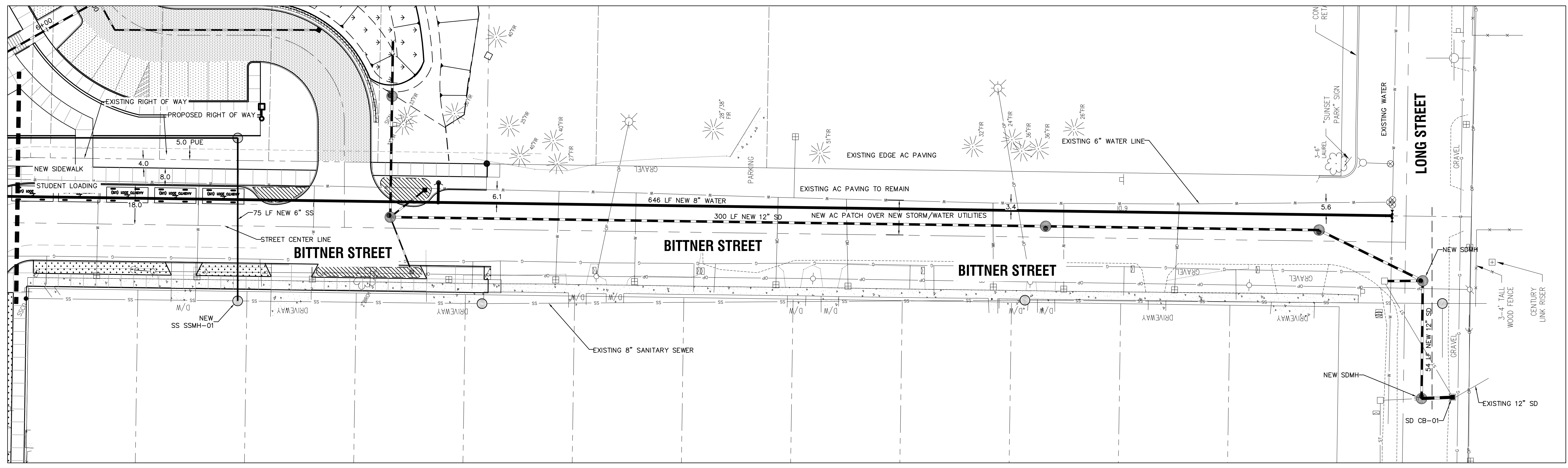

**BITTNER STREET ROW PLAN**

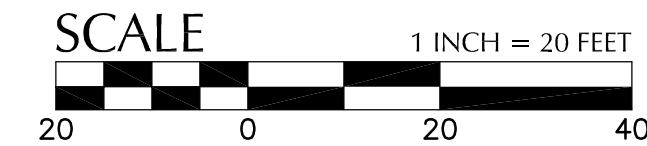
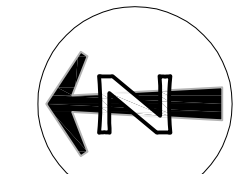

8/17/2015 8:19:12 AM  
 N:\c\2015\15015\15015-08-10\W\W\ARMS.rvt

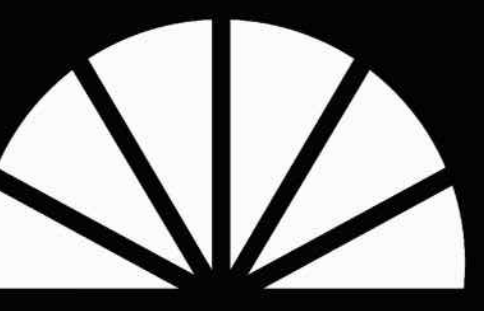

WEST LINN WILSONVILLE  
 2755 SW Borland Road  
 Tualatin, OR 97062  
 (503) 673 7995



Dull Olson Weekes - IBI Group  
 Architects, Inc.

907 SW Stark Street Portland, OR 97205 USA  
 tel: 503 226 6950 fax: 503 273 9192  
 www.dova-ibigroup.com www.ibigroup.com

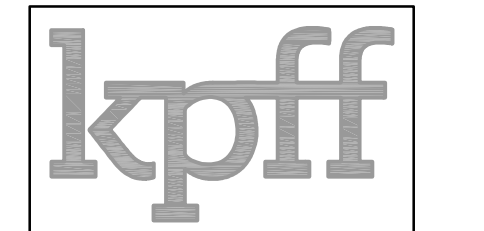

111 SW Fifth Ave., Suite 2500  
 Portland, OR 97204  
 O: 503.227.3551  
 F: 503.274.4663  
 www.kpff.com

PRELIMINARY  
 NOT FOR  
 CONSTRUCTION

SUNSET REVISIONING  
 West Linn Wilsonville  
 2351 Oxford St, West Linn, OR 97068  
 t: (503) 673-7988

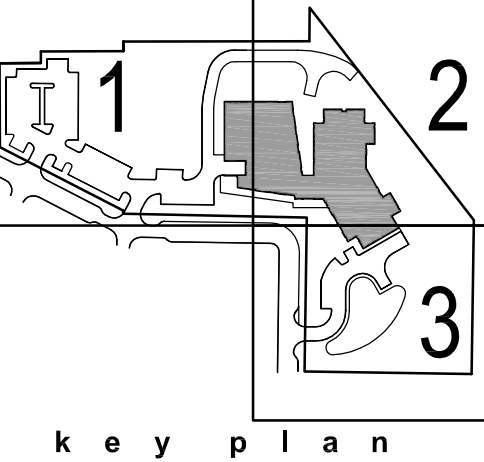

phase	LAND USE
date	JANUARY 8, 2016
revisions	
project #	15015
SLOPE ANALYSIS	

**LU1.08**

LAND TYPE	MINIMUM SLOPE	MAXIMUM SLOPE	AREA (%)
TYPE I	0.00%	15.00%	94.00
TYPE II	15.00%	25.00%	4.75
TYPE III	25.00%	35.00%	0.92
TYPE IV	35.00%	100.00%	0.33
			100%

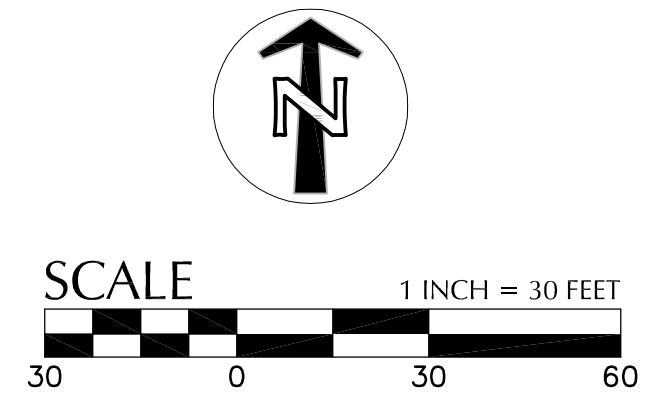
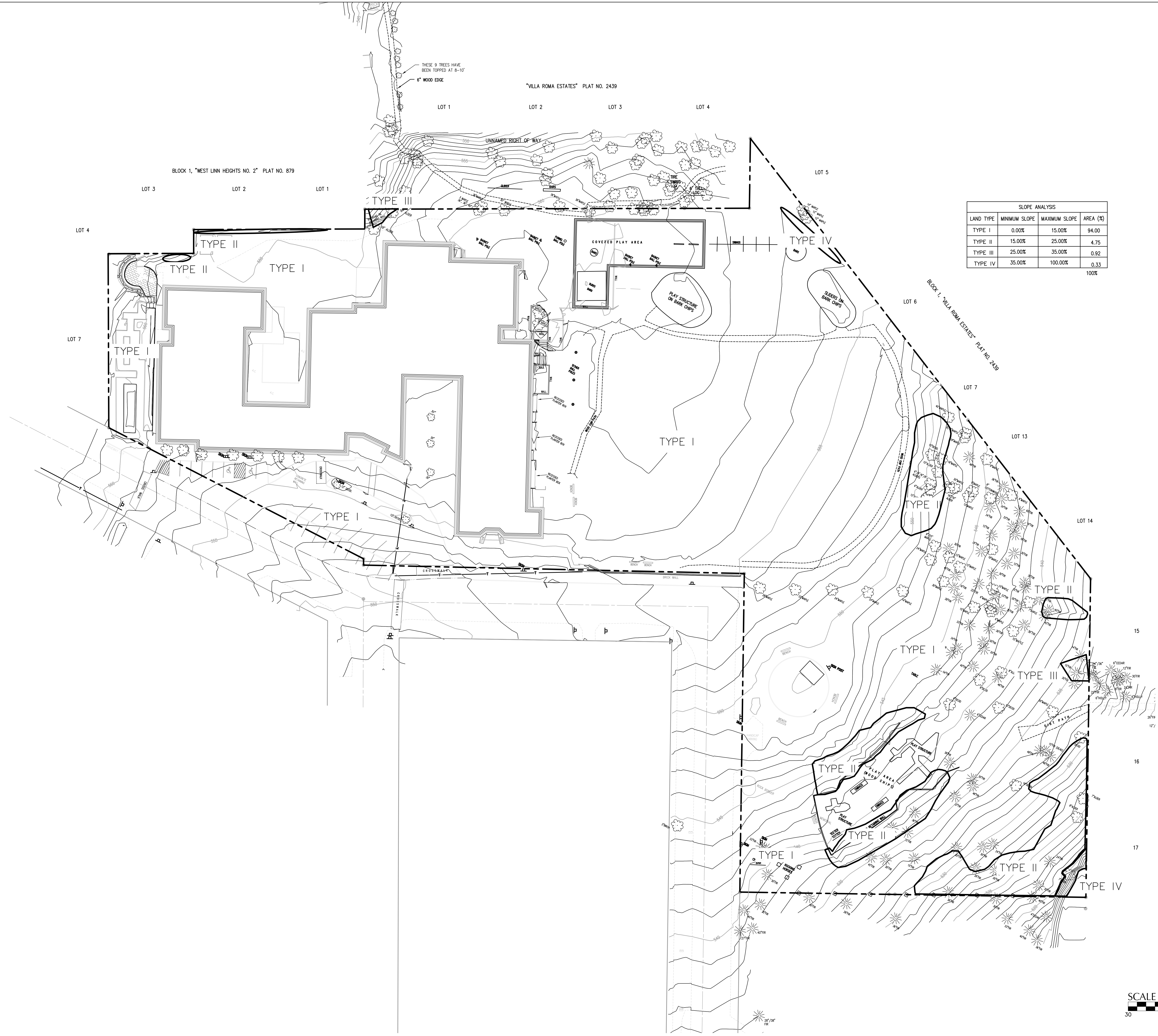

8/17/2015 8:19:12 AM N:\c\201515315087-Sunset-Primary-School\FILE-TRANS\IN\20150810-REV\15-08-10 WL\WV ARMS.rvt

10/13/2015 7:14:39 PM  
 C:\Users\ken.riddle\Documents\15015\_Sunset\_PS\_CENTRAL\_ken.riddle.nt

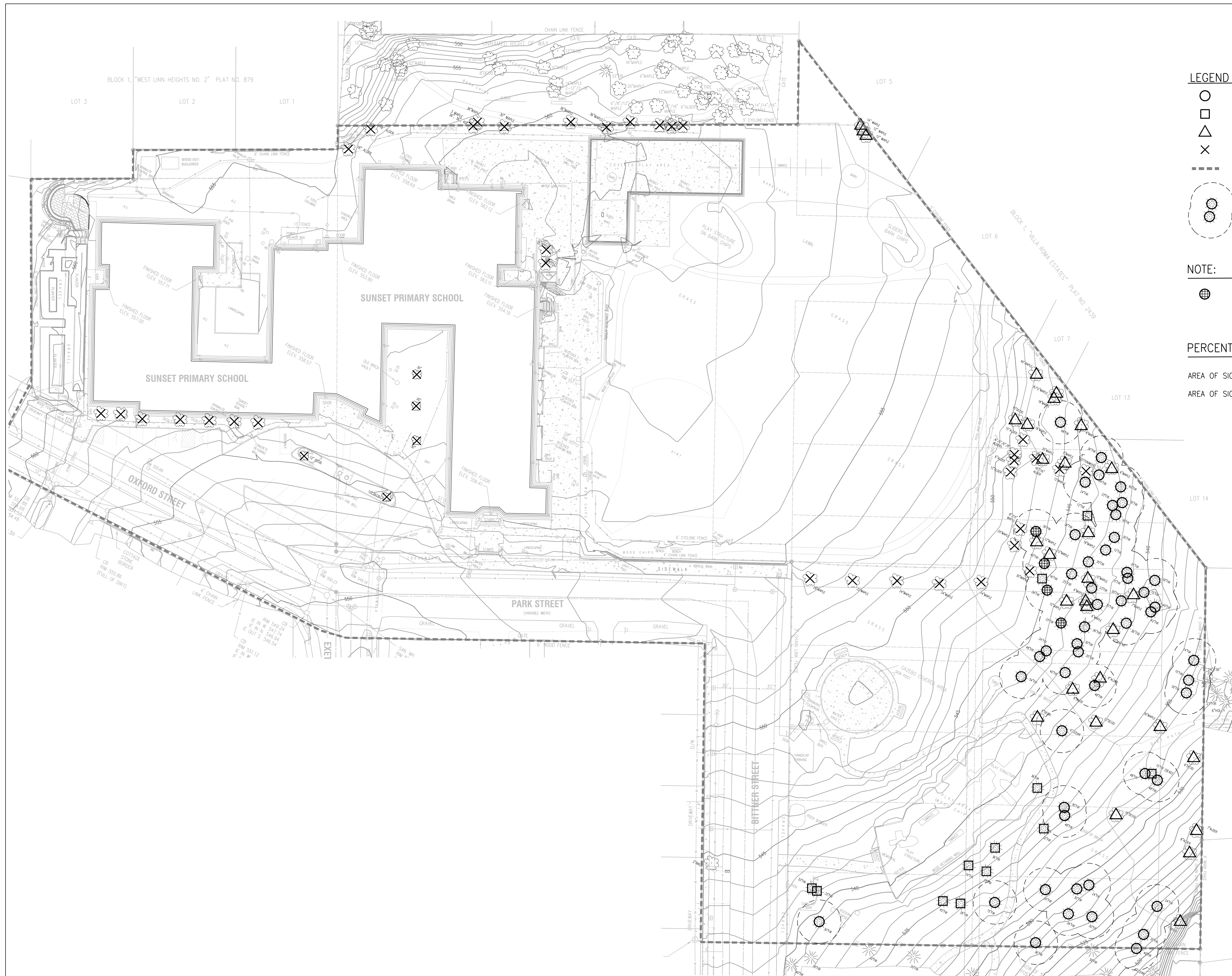

- LEGEND**
- (50) SIGNIFICANT TREE: PROTECT-IN-PLACE
  - (12) SIGNIFICANT TREE: TO BE REMOVED
  - △ (31) EXISTING TREE: PROTECT-IN-PLACE
  - × (40) EXISTING TREE: TO BE REMOVED
  - LIMIT OF WORK
  - (with dots) PROTECTED SIGNIFICANT TREES OR TREE CLUSTERS (DRIPLINE + 10 FT.) OR AS PER ARBORIST'S RECOMMENDATION.

**NOTE:**

- ⊕ THE EXPRESS GOAL OF THE PROJECT IS TO KEEP THESE TREES, BUT THEY WILL NEED TO BE EVALUATED OVER THE COURSE OF THE PROJECT DUE TO THE RELATIVE RISK OF THE PROXIMITY TO THE STRUCTURE.

**PERCENTAGE CALCULATION:**

AREA OF SIGNIFICANT TREES: PROTECT-IN-PLACE (DRIPLINE + 10') = 24,302 SF (77%)  
 AREA OF SIGNIFICANT TREES: TO BE REMOVED (DRIPLINE + 10') = 7,129 SF (23%)

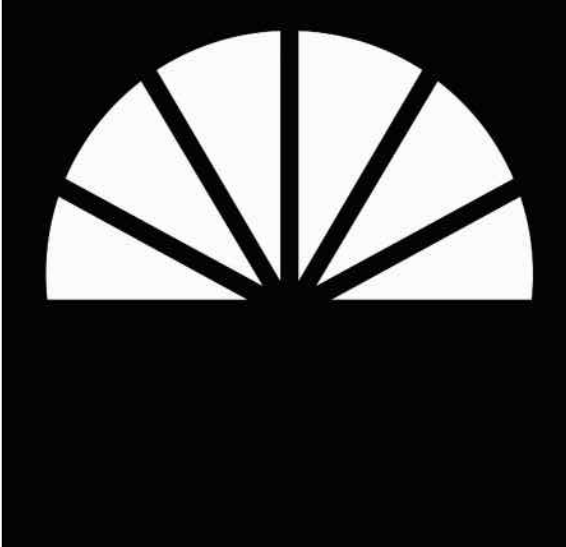

**WEST LINN WILSONVILLE**  
 2755 SW Borland Road  
 Tualatin, OR 97062  
 (503) 673 7995



**Dull Olson Weekes - IBI Group Architects, Inc.**

907 SW Stark Street Portland, OR 97205 USA  
 tel 503 226 8950 fax 503 273 9192  
 www.dowa-ibigroup.com www.ibigroup.com

**SUNSET REVISIONING**  
**West Linn - Wilsonville School District**  
 2351 Oxford St, West Linn, OR 97068  
 t: (503) 673-7988

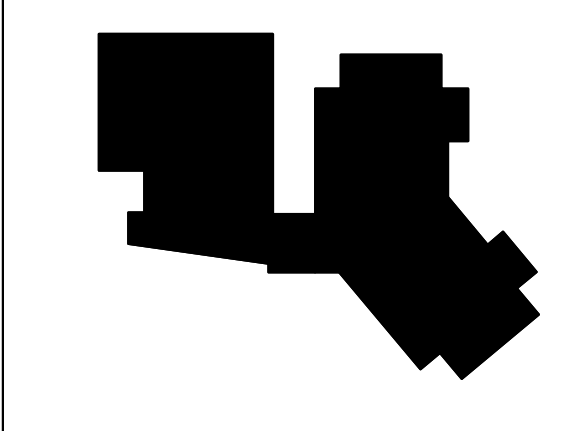

phase	LAND USE
date	November 13, 2015
revisions	January 8, 2016
project #	15015
Tree Removal Plan	

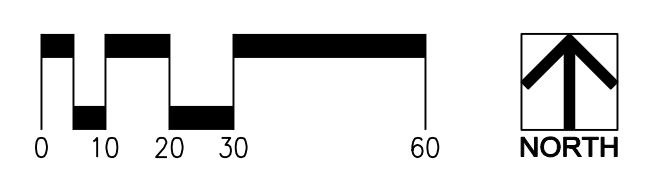

**LU2.01**

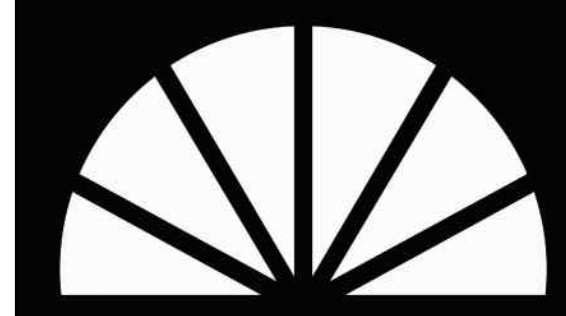

WEST LINN WILSONVILLE  
 2755 SW Borland Road  
 Tualatin, OR 97062  
 (503) 673 7995

**dowa** | **IBI GROUP**  
**Dull Olson Weekes - IBI Group**  
 Architects, Inc.  
 907 SW Stark Street Portland, OR 97205 USA  
 tel: 503 226 6950 fax: 503 273 9192  
 www.dowa-ibigroup.com www.ibigroup.com

**LEGEND**

- PEDESTRIAN CONCRETE PAVING
  - VEHICULAR CONCRETE PAVING
  - AGGREGATE PAVING W/STEEL EDGER
  - SOFT PLAY SURFACING
  - FIRE ACCESS AND TURNAROUND
  - 6' TALL GALVANIZED CHAINLINK FENCE
  - SEPARATION FENCE
  - GUARD RAIL
  - PAINTED GAMES
  - 3.5'x8' GARDEN PLANTER
  - FIXED SEATING & TABLE
  - BASKETBALL HOOP
  - BIKE RACK
  - FLAG POLE
  - VEHICULAR BOLLARD
  - REMOVABLE VEHICULAR BOLLARD
  - BENCH
  - CONCRETE SEAT WALL
  - 12" CONCRETE BAND AT PLAY SURFACING
- NOTE: SEE SHEET LU1.03 FOR EROSION CONTROLS

**PLANTING AND IRRIGATION LEGEND**

- LAWN AREAS WITH PERMANENT IRRIGATION
- PLANTING AREAS WITH PERMANENT IRRIGATION
- BARK MULCH
- LOW-IMPACT BARK MULCH PATH (NOT ACCESSIBLE). MAKE MINOR ADJUSTMENTS IN THE FIELD TO AVOID DAMAGING EXISTING TREES.
- WATER QUALITY PLANTINGS AT STORMWATER SWALES AND DETENTION AREAS WITH PERMANENT IRRIGATION
- BUFFER TREE
- STREET TREE
- FLOWERING TREE
- PARKING LOT TREE
- EXISTING TREE

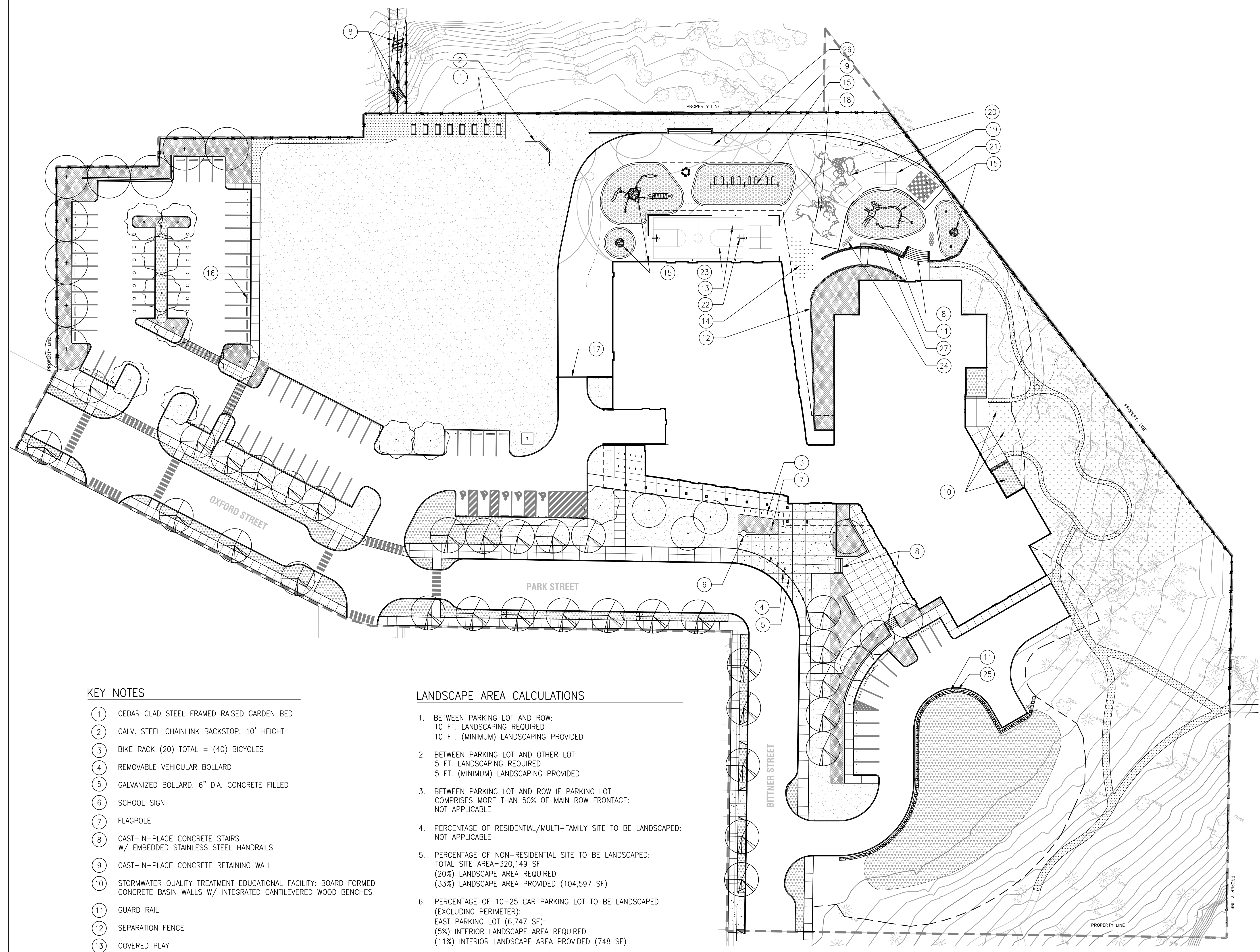

**KEY NOTES**

- 1 CEDAR CLAD STEEL FRAMED RAISED GARDEN BED
- 2 GALV. STEEL CHAINLINK BACKSTOP, 10' HEIGHT
- 3 BIKE RACK (20) TOTAL = (40) BICYCLES
- 4 REMOVABLE VEHICULAR BOLLARD
- 5 GALVANIZED BOLLARD, 6" DIA. CONCRETE FILLED
- 6 SCHOOL SIGN
- 7 FLAGPOLE
- 8 CAST-IN-PLACE CONCRETE STAIRS W/ EMBEDDED STAINLESS STEEL HANDRAILS
- 9 CAST-IN-PLACE CONCRETE RETAINING WALL
- 10 STORMWATER QUALITY TREATMENT EDUCATIONAL FACILITY: BOARD FORMED CONCRETE BASIN WALLS W/ INTEGRATED CANTILEVERED WOOD BENCHES
- 11 GUARD RAIL
- 12 SEPARATION FENCE
- 13 COVERED PLAY
- 14 PLAY POLES
- 15 PLAYGROUND EQUIPMENT
- 16 PRE-CAST CONCRETE WHEEL STOP
- 17 GALVANIZED STEEL VEHICULAR SWING GATE, MANUAL OPERATION & MANUAL LOCK W/ KNOX BOX FOR EMERGENCY ACCESS
- 18 20' X 40' NORTH AMERICA GRAPHIC
- 19 16' X 16' FOURSQUARE GAME
- 20 TETHER BALL GAME, EMBEDDED
- 21 16' X 16' CHESS GAME
- 22 BASKETBALL GOAL
- 23 BASKETBALL COURT STRIPING
- 24 18' X 18' HOPSCOTCH GAME
- 25 RETAINING WALL
- 26 PAINTED GAMES
- 27 CUSTOM INTEGRAL WOOD BENCH

**LANDSCAPE AREA CALCULATIONS**

- 1. BETWEEN PARKING LOT AND ROW:  
10 FT. LANDSCAPING REQUIRED  
10 FT. (MINIMUM) LANDSCAPING PROVIDED
- 2. BETWEEN PARKING LOT AND OTHER LOT:  
5 FT. LANDSCAPING REQUIRED  
5 FT. (MINIMUM) LANDSCAPING PROVIDED
- 3. BETWEEN PARKING LOT AND ROW IF PARKING LOT COMPRISES MORE THAN 50% OF MAIN ROW FRONTAGE:  
NOT APPLICABLE
- 4. PERCENTAGE OF RESIDENTIAL/MULTI-FAMILY SITE TO BE LANDSCAPED:  
NOT APPLICABLE
- 5. PERCENTAGE OF NON-RESIDENTIAL SITE TO BE LANDSCAPED:  
TOTAL SITE AREA=320,149 SF  
(20%) LANDSCAPE AREA REQUIRED  
(33%) LANDSCAPE AREA PROVIDED (104,597 SF)
- 6. PERCENTAGE OF 10-25 CAR PARKING LOT TO BE LANDSCAPED (EXCLUDING PERIMETER):  
EAST PARKING LOT (6,747 SF):  
(5%) INTERIOR LANDSCAPE AREA REQUIRED  
(11%) INTERIOR LANDSCAPE AREA PROVIDED (748 SF)
- 7. PERCENTAGE OF 1-9 CAR PARKING LOT TO BE LANDSCAPED:  
NOT APPLICABLE
- 8. PERCENTAGE OF 26+ CAR PARKING LOT TO BE LANDSCAPED (EXCLUDING PERIMETER):  
(10%) INTERIOR LANDSCAPE AREA REQUIRED  
(14%) INTERIOR LANDSCAPE AREA PROVIDED (4,654 SF)

10/13/2015 7:14:39 PM C:\Users\ken.riddle\Documents\15015\_Sunset PS\_CENTRAL\_ken.riddle.rvt

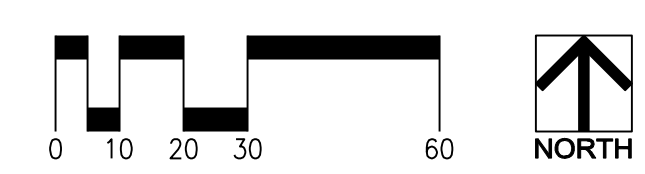

**SUNSET REVISIONING**  
 West Linn - Wilsonville School District  
 2351 Oxford St, West Linn, OR 97068  
 t: (503) 673-7988

phase	LAND USE
date	November 13, 2015
revisions	January 8, 2016
project #	15015
Landscape Plan	

**LU2.02**



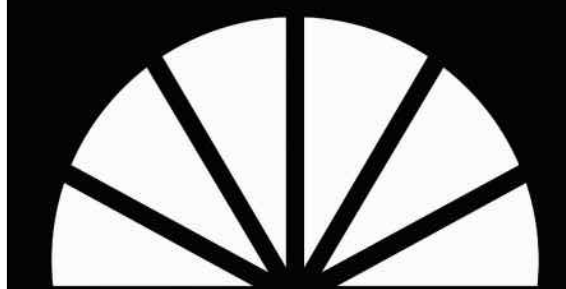

WEST LINN WILSONVILLE  
 2755 SW Borland Road  
 Tualatin, OR 97062  
 (503) 673 7995



Dull Olson Weekes - IBI Group  
 Architects, Inc.

907 SW Stark Street Portland, OR 97205 USA  
 tel 503 226 6550 fax 503 273 3192  
 www.dowa-ibigroup.com www.ibigroup.com

**SUNSET REVISIONING**  
 West Linn - Wilsonville School District  
 2351 Oxford St, West Linn, OR 97068  
 t: (503) 673-7988



phase | LAND USE

date | November 13, 2015

revisions | January 8, 2016

project # | 15015  
 Landscape Planting Plan

**LU2.03**

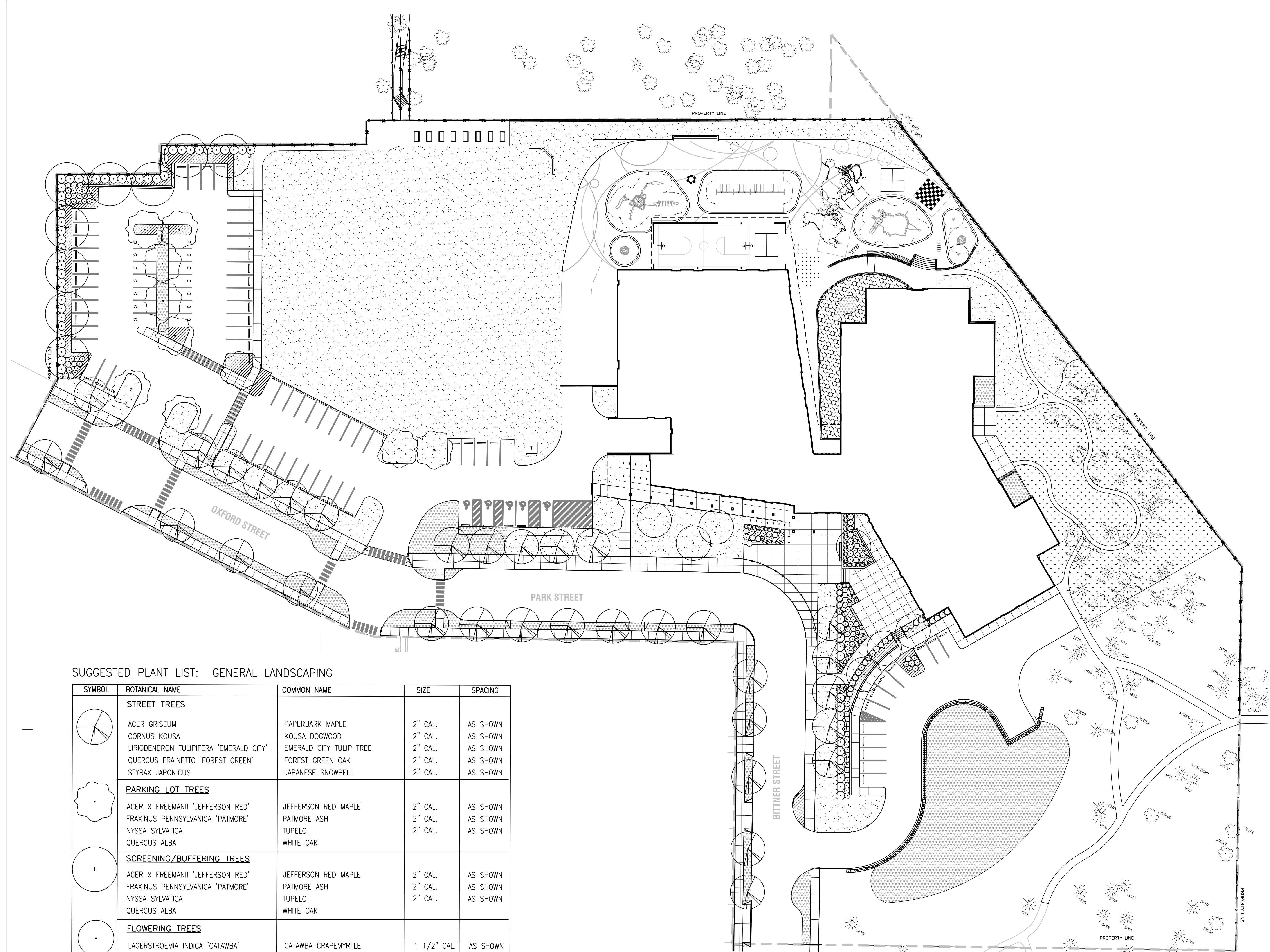

SUGGESTED PLANT LIST: GENERAL LANDSCAPING

SYMBOL	BOTANICAL NAME	COMMON NAME	SIZE	SPACING
<b>STREET TREES</b>				
[Symbol]	ACER GRISEUM	PAPERBARK MAPLE	2" CAL.	AS SHOWN
	CORNUS KOUSA	KOUSA DOGWOOD	2" CAL.	AS SHOWN
	LIRIODENDRON TULIPIFERA 'EMERALD CITY'	EMERALD CITY TULIP TREE	2" CAL.	AS SHOWN
	QUERCUS FRAINETTO 'FOREST GREEN'	FOREST GREEN OAK	2" CAL.	AS SHOWN
	STYRAX JAPONICUS	JAPANESE SNOWBELL	2" CAL.	AS SHOWN
<b>PARKING LOT TREES</b>				
[Symbol]	ACER X FREEMANII 'JEFFERSON RED'	JEFFERSON RED MAPLE	2" CAL.	AS SHOWN
	FRAXINUS PENNSYLVANICA 'PATMORE'	PATMORE ASH	2" CAL.	AS SHOWN
	NYSSA SYLVATICA	TUPELO	2" CAL.	AS SHOWN
<b>SCREENING/BUFFERING TREES</b>				
[Symbol]	ACER X FREEMANII 'JEFFERSON RED'	JEFFERSON RED MAPLE	2" CAL.	AS SHOWN
	FRAXINUS PENNSYLVANICA 'PATMORE'	PATMORE ASH	2" CAL.	AS SHOWN
	NYSSA SYLVATICA	TUPELO	2" CAL.	AS SHOWN
	QUERCUS ALBA	WHITE OAK	2" CAL.	AS SHOWN
<b>FLOWERING TREES</b>				
[Symbol]	LAGERSTROEMIA INDICA 'CATAWBA'	CATAWBA CRAPEMYRTLE	1 1/2" CAL.	AS SHOWN
	MAGNOLIA GRANDIFLORA 'EDITH BOGUE'	EDITH BOGUE SOUTHERN MAGNOLIA	1 1/2" CAL.	AS SHOWN
	PRUNUS SERRULATA 'KWANZAN'	KWANZAN CHERRY	1 1/2" CAL.	AS SHOWN
	SYRINGA RETICULATA	JAPANESE TREE LILAC	1 1/2" CAL.	AS SHOWN
<b>SMALL SHRUBS</b>				
[Symbol]	SPIRAEA JAPONICA CVS.	JAPANESE SPIREA	1 GAL.	AS SHOWN
	LONICERA PILEATA	BOX HONEYSUCKLE	1 GAL.	AS SHOWN
	NANDINA DOMESTICA 'HARBOR DWARF'	HARBOR DWARF HEAVENLY BAMBOO	1 GAL.	AS SHOWN
	RHODODENDRON SPP.	RHODODENDRON	1 GAL.	AS SHOWN
	<b>MEDIUM SHRUBS</b>			
[Symbol]	CISTUS SPP.	ROCKROSE	1 GAL.	AS SHOWN
	BERBERIS X GLADWYNENSIS 'WILLIAM PENN'	WILLIAM PENN BARBERRY	1 GAL.	AS SHOWN
	LONICERA NITIDA	BOX HONEYSUCKLE	1 GAL.	AS SHOWN
	VIBURNUM DAVIDII	DAVID VIBURNUM	1 GAL.	AS SHOWN
<b>LARGE SHRUBS</b>				
[Symbol]	CEANOTHUS 'VICTORIA'	CALIFORNIA LILAC	5 GAL.	AS SHOWN
	LIGUSTRUM JAPONICUM 'TEXANUM'	WAX-LEAF PRIVET	5 GAL.	AS SHOWN
	MYRICA CALIFORNICA	PACIFIC WAX MYRTLE	5 GAL.	AS SHOWN
	VIBURNUM TINUS	LAURUSTINUS VIBURNUM	5 GAL.	AS SHOWN

SUGGESTED PLANT LIST: GENERAL LANDSCAPING

<b>NATIVE PLANTING</b>				
[Symbol]	ACER CIRCINATUM	VINE MAPLE	6-8' B&B	AS SHOWN
[Symbol]	AMELANCHIER ALNIFOLIA	WESTERN SERVICEBERRY	5 GAL.	8" O.C.
[Symbol]	POLYSTICHUM MUNITUM	SWORD FERN	1 GAL.	3' O.C.
[Symbol]	SPIREA DOUGLASHII	DOUGLAS SPIREA	5 GAL.	5' O.C.
[Symbol]	SYMPHORICARPOS ALBUS	SNOWBERRY	1 GAL.	3' O.C.
[Symbol]	THUJA PLICATA 'HOGAN'	HOGAN WESTERN RED CEDAR	6-8' B&B	AS SHOWN
<b>GROUND COVER</b>				
[Symbol]	COTONEASTER DAMMERI	BEARBERRY COTONEASTER	1 GAL.	36" O.C.
[Symbol]	FRAGARIA CHILOENSIS	STRAWBERRY	1 GAL.	36" O.C.
[Symbol]	MAHONIA REPENS	CREeping MAHONIA	1 GAL.	36" O.C.
[Symbol]	RUBUS CALYCINOIDES	BRAMBLE	1 GAL.	36" O.C.
[Symbol]	WALDSTEINIA FRAGRARIODES	BARREN STRAWBERRY	1 GAL.	36" O.C.
<b>OTHER</b>				
[Symbol]	SEEDED LAWN	SEE SPECS.		
[Symbol]	BARK MULCH	SEE SPECS.		
[Symbol]	EXISTING TREE			
[Symbol]	LIMIT OF WORK			

SUGGESTED PLANT LIST: STORMWATER FACILITIES

SYMBOL	BOTANICAL NAME	COMMON NAME	SIZE	SPACING
<b>HERBACEOUS</b>				
[Symbol]	DESCHAMPSIA CESPIIOSA	TUFTED HAIRGRASS	4" POT	12" O.C.
[Symbol]	JUNCUS PATENS	SPREADING RUSH	4" POT	12" O.C.
[Symbol]	SCIRPUS MICROCARPUS	SMALL FRUITED BULRUSH	4" POT	12" O.C.
<b>SHRUBS</b>				
[Symbol]	CORNUS SERICEA 'KELSEY'	KELSEY DOGWOOD	1 GAL.	30" O.C.
[Symbol]	MAHONIA AQUIFOLIUM 'COMPACTA'	COMPACT OREGON GRAPE	1 GAL.	4" O.C.
[Symbol]	SPIRAEA DOUGLASHII	DOUGLAS SPIREA	1 GAL.	5" O.C.
<b>GROUND COVER</b>				
[Symbol]	GAULTHERIA SHALLON	SALAL	4" POT	36" O.C.
[Symbol]	MAHONIA REPENS	CREeping MAHONIA	4" POT	36" O.C.
<b>SEED</b>				
[Symbol]	HYDROSEED PROTOME 840	NATIVE BIO-FILTER MIX	1 LB/1000 SF	

10/13/2015 7:14:39 PM C:\Users\ken.riddle\Documents\15015\_Sunset PS\_CENTRAL\_ken.riddle.rvt



WEST LINN WILSONVILLE  
 2755 SW Borland Road  
 Tualatin, OR 97062  
 (503) 673 7995



Dull Olson Weekes - IBI Group  
 Architects, Inc.

907 SW Stark Street Portland OR 97205 USA  
 tel: 503 226 6950 fax: 503 273 9192  
 www.dowe-ibigroup.com www.ibigroup.com

**SUNSET REVISIONING**  
 West Linn - Wilsonville School District  
 2351 Oxford St, West Linn, OR 97068  
 t: (503) 673-7988

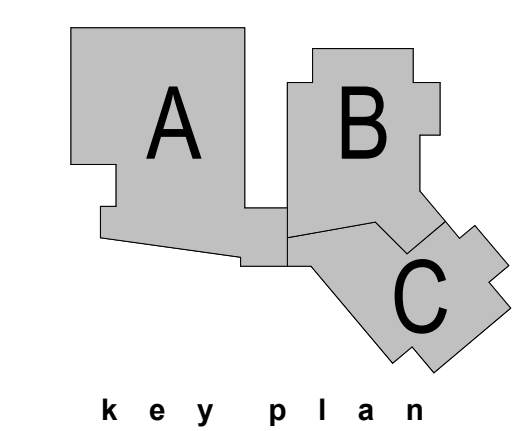

phase	LAND USE
date	November 13, 2015
revisions	January 8, 2016

project # 15015  
 MAIN FLOOR PLAN

**LU3.01**

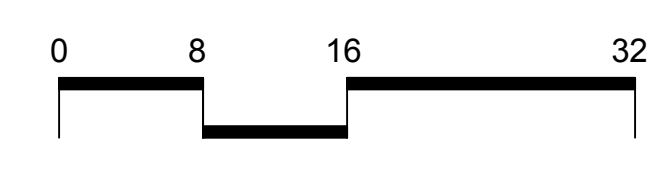
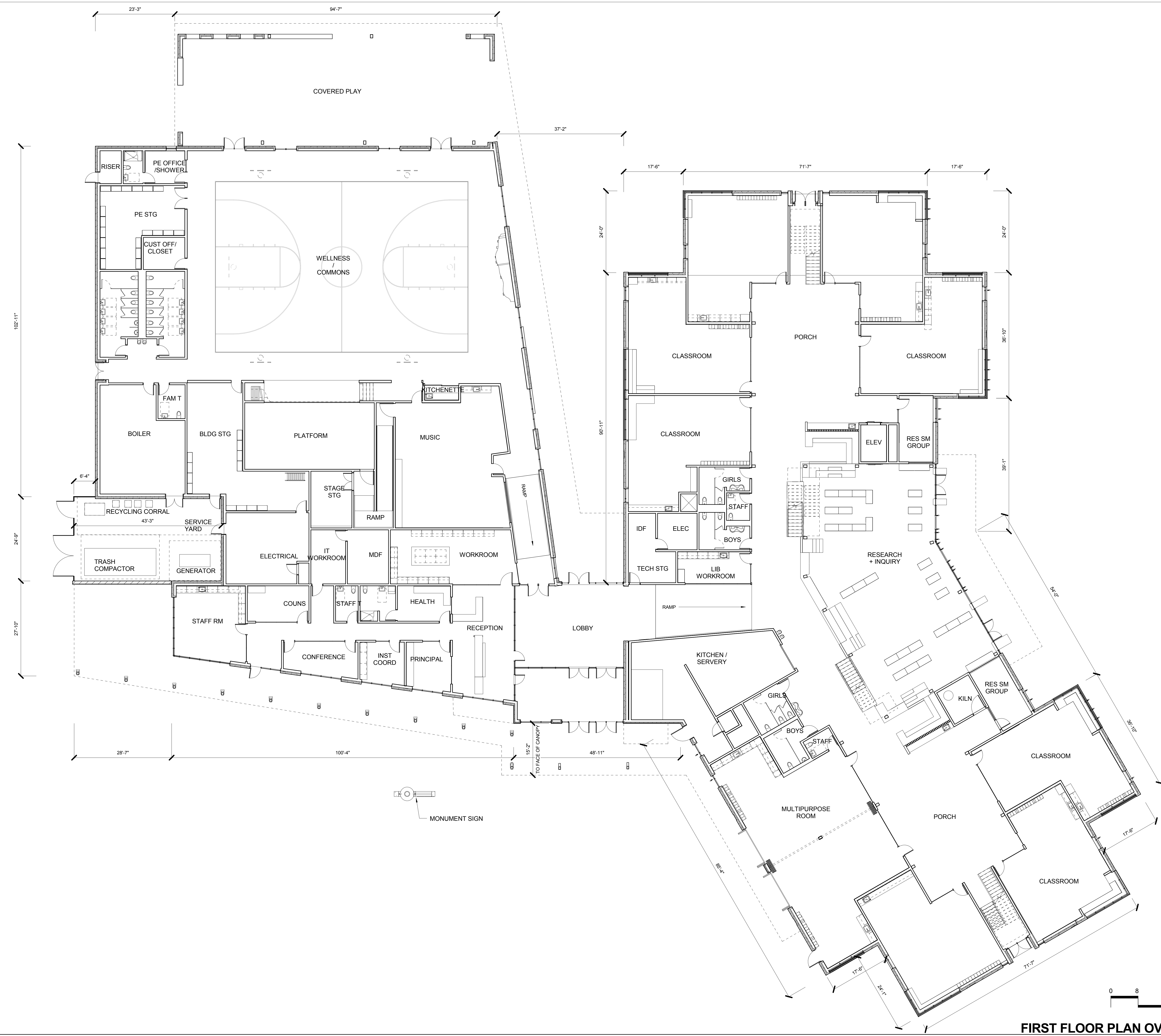

**FIRST FLOOR PLAN OVERALL** 1  
 SCALE: 3/32" = 1'-0"

1/6/2016 12:03:43 PM  
 JV15015\_SunsetRevisioning15.3 Approvals - Code & AHJ.Landuse Dwg16-0108 Completeness ResubmittalARCH Revit  
 modelARCH\_SPS.rvt

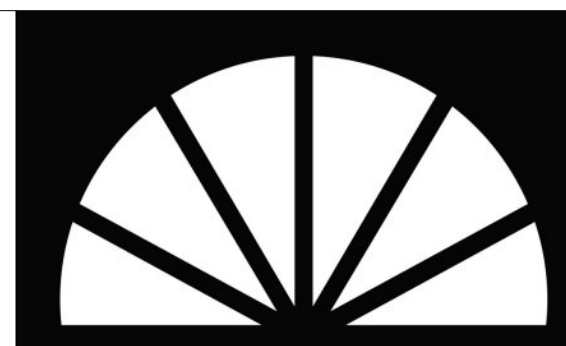

WEST LINN WILSONVILLE  
 2755 SW Borland Road  
 Tualatin, OR 97062  
 (503) 673 7995



Dull Olson Weekes - IBI Group  
 Architects, Inc.

907 SW Stark Street Portland OR 97205 USA  
 tel: 503 226 6950 fax: 503 273 9192  
 www.dowe-ibigroup.com www.ibigroup.com

**SUNSET REVISIONING**  
 West Linn - Wilsonville School District  
 2351 Oxford St, West Linn, OR 97068  
 t: (503) 673-7988

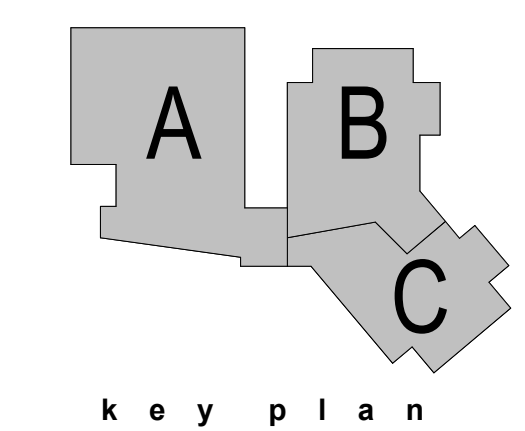

phase	LAND USE
date	November 13, 2015
revisions	January 8, 2016

project # 15015  
 SECOND FLOOR PLAN

**LU3.02**

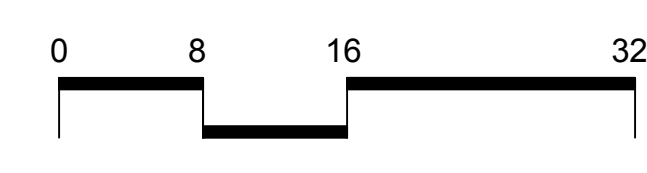
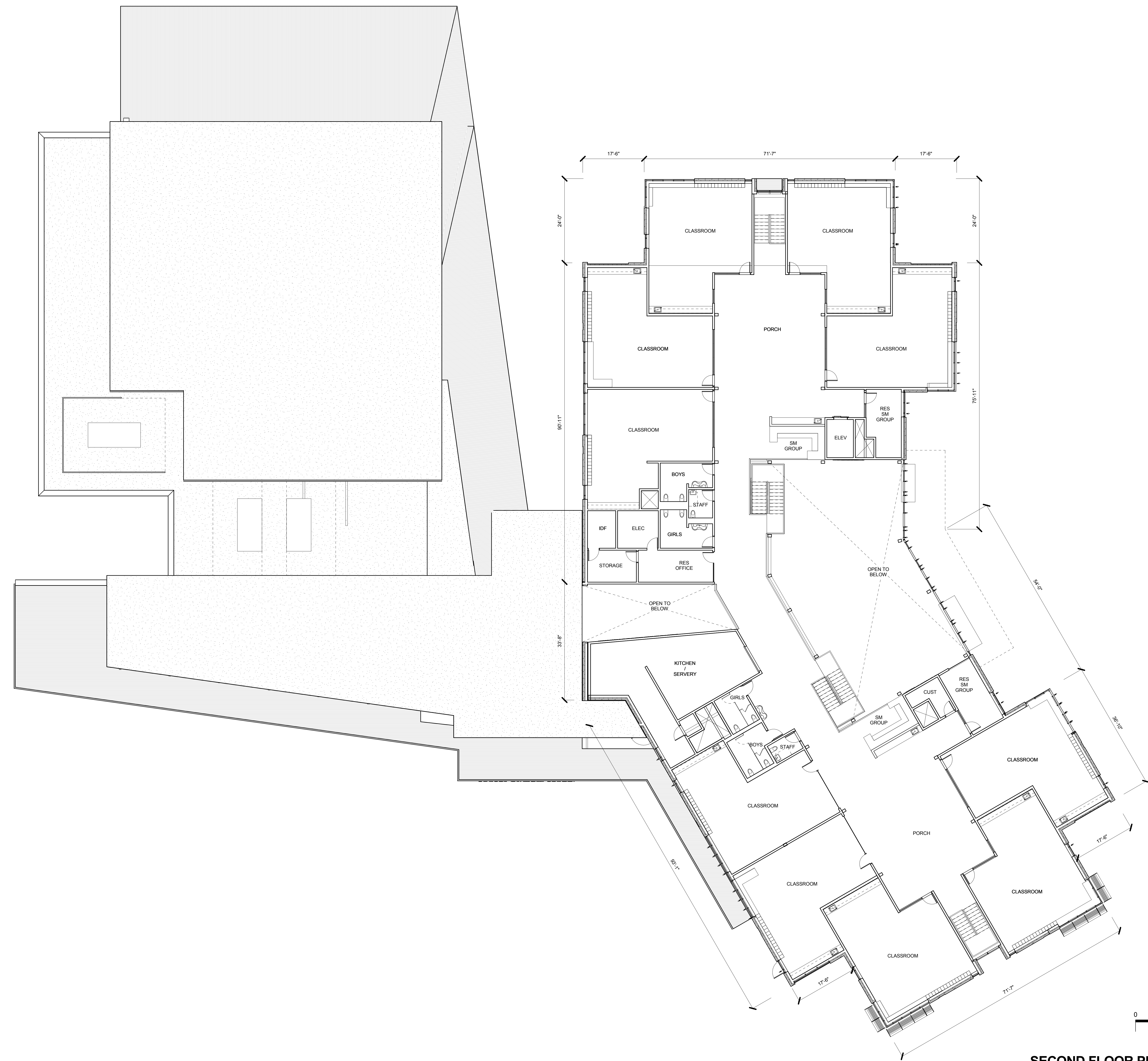

**SECOND FLOOR PLAN OVERALL** 1  
 SCALE: 3/32" = 1'-0"

1/6/2016 12:04:43 PM  
 JV15015\_SunsetRevisioning\_3 Approvals - Code & AHJ.Landuse Dwg\16-0108 Completeness Resubmit\ARCH Revit  
 model\ARCH\_SPS.rvt



WEST LINN WILSONVILLE  
 2755 SW Borland Road  
 Tualatin, OR 97062  
 (503) 673-7995

**dowa** | **IBI GROUP**  
 Dull Olson Weekes - IBI Group  
 Architects, Inc.

907 SW Stark Street Portland OR 97205 USA  
 tel: 503 226 6950 fax: 503 273 9192  
 www.dowa-ibigroup.com www.ibigroup.com

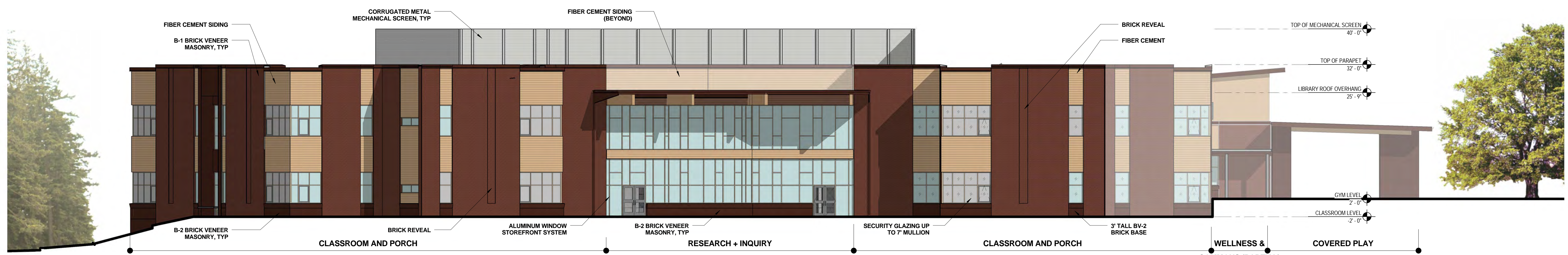

**EXTERIOR ELEVATION OVERALL - EAST** ①  
 SCALE: 1" = 10'-0"

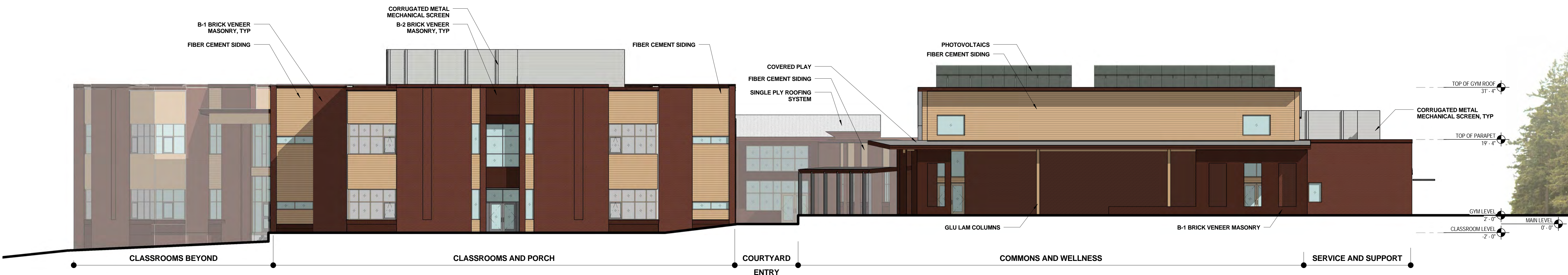

**EXTERIOR ELEVATION OVERALL - NORTH** ②  
 SCALE: 1" = 10'-0"

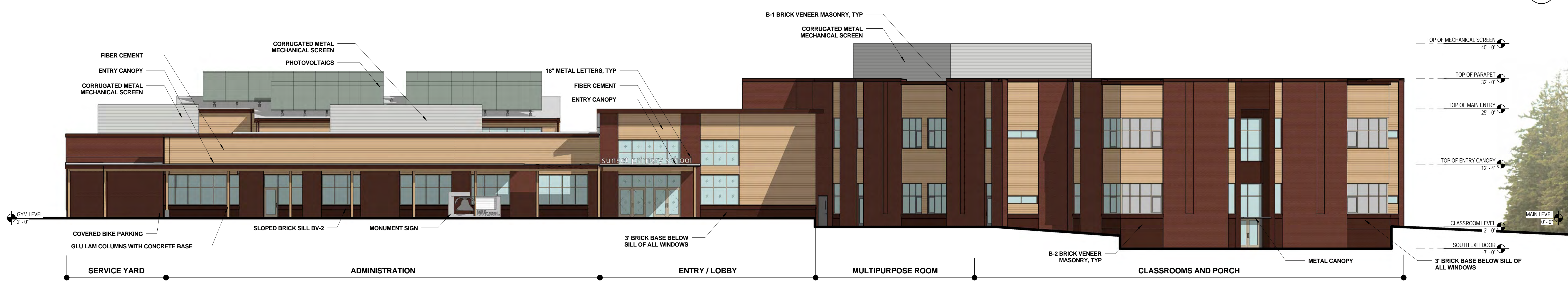

**EXTERIOR ELEVATION OVERALL - SOUTH** ③  
 SCALE: 1" = 10'-0"

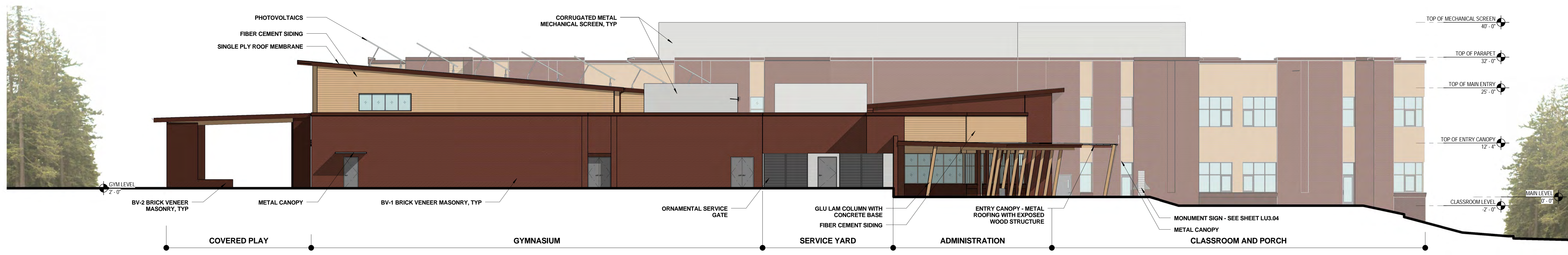

**EXTERIOR ELEVATION OVERALL - WEST** ④  
 SCALE: 1" = 10'-0"

**SUNSET REVISIONING**  
 West Linn - Wilsonville School District  
 2351 Oxford St, West Linn, OR 97068  
 t: (503) 673-7988

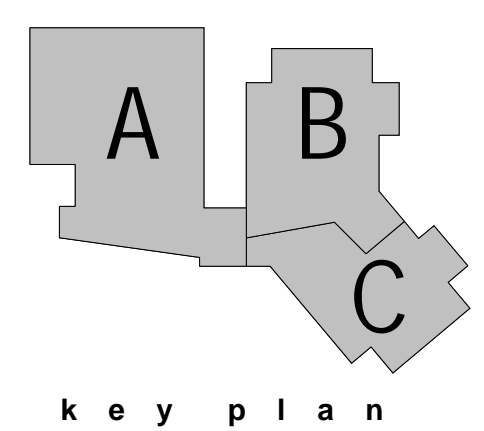

phase	LAND USE
date	November 13, 2015
revisions	January 8, 2016
	February 22, 2016

project # 15015  
 EXTERIOR ELEVATIONS

**LU3.03**

2/19/2016 2:34:45 PM C:\Users\ken.riddle\Documents\15015\_Sunset\_PS\_CENTRAL\_ken.riddle.rvt

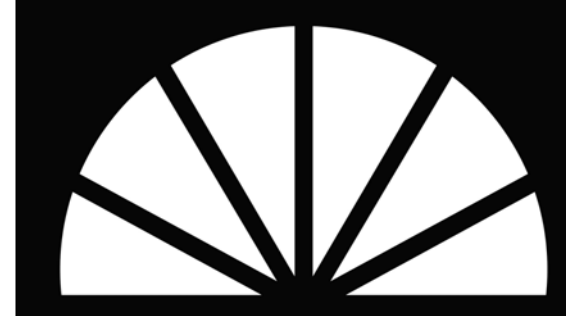

WEST LINN WILSONVILLE  
 2755 SW Borland Road  
 Tualatin, OR 97062  
 (503) 673 7995



Dull Olson Weekes - IBI Group  
 Architects, Inc.

907 SW Stark Street Portland OR 97205 USA  
 tel: 503 226 6950 fax: 503 273 9192  
 www.dowe-ibigroup.com www.ibigroup.com

**SUNSET REVISIONING**  
 West Linn - Wilsonville School District  
 2351 Oxford St, West Linn, OR 97068  
 t: (503) 673-7988

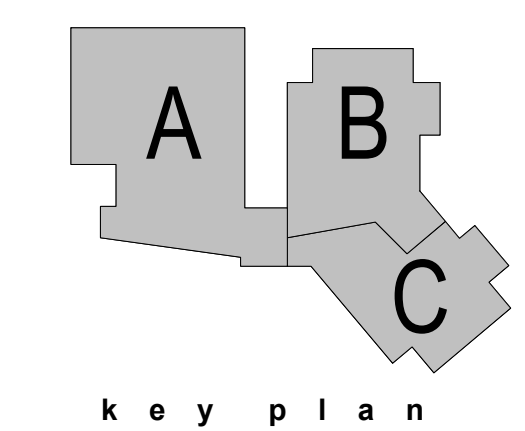

phase	LAND USE
date	November 13, 2015
revisions	January 8, 2016
	February 22, 2016

project # 15015  
 BUILDING SECTIONS &  
 SIGN

**LU3.04**

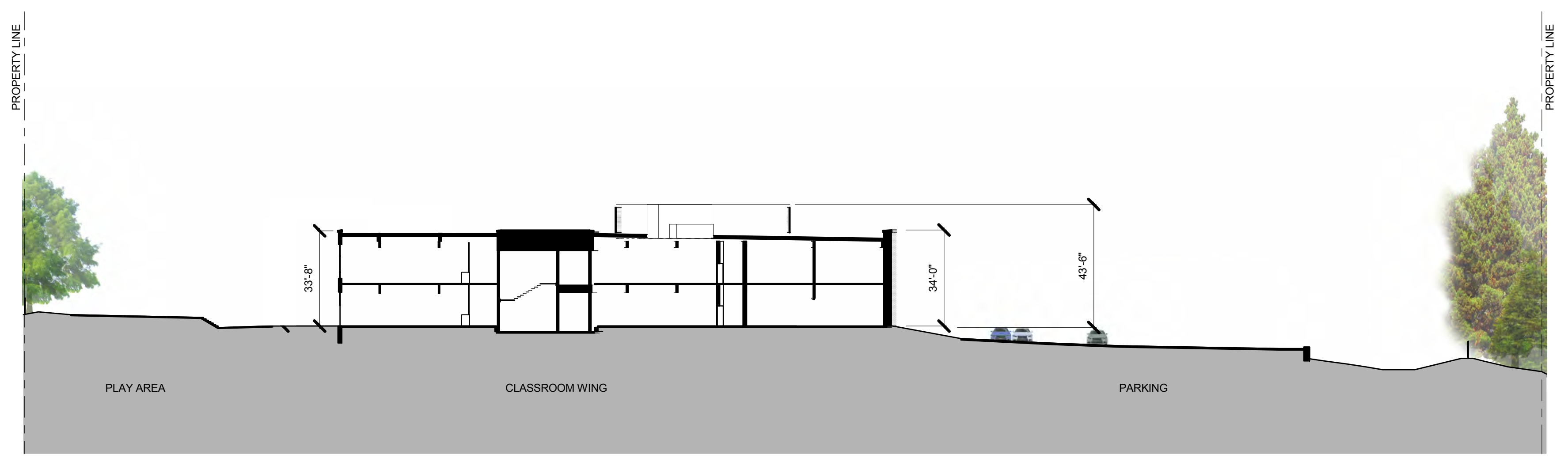

**SITE SECTION 5**  
 SCALE: 1" = 30'-0"

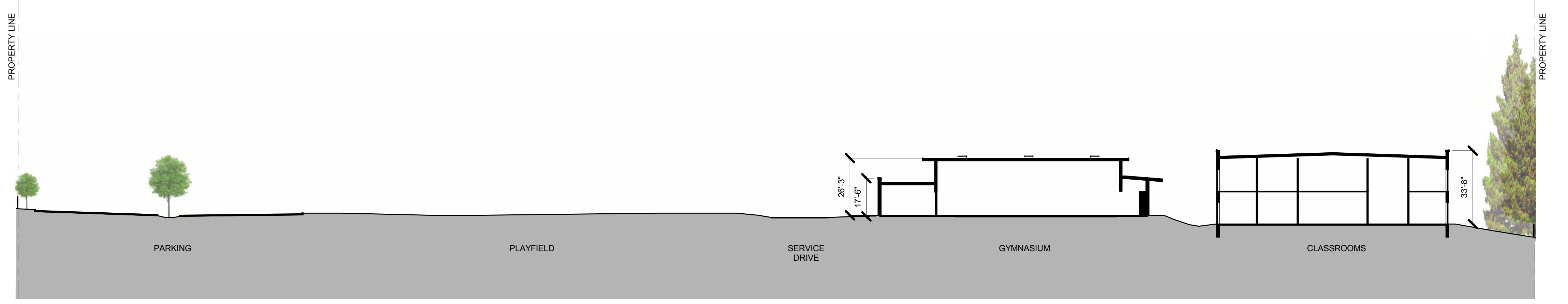

**SITE SECTION 4**  
 SCALE: 1" = 30'-0"

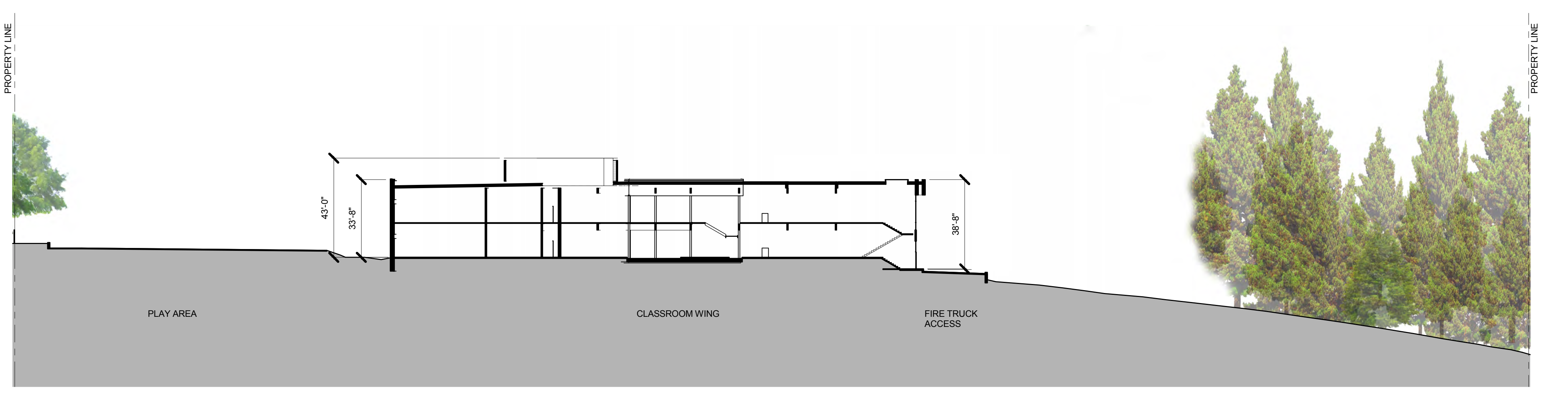

**SITE SECTION 3**  
 SCALE: 1" = 30'-0"

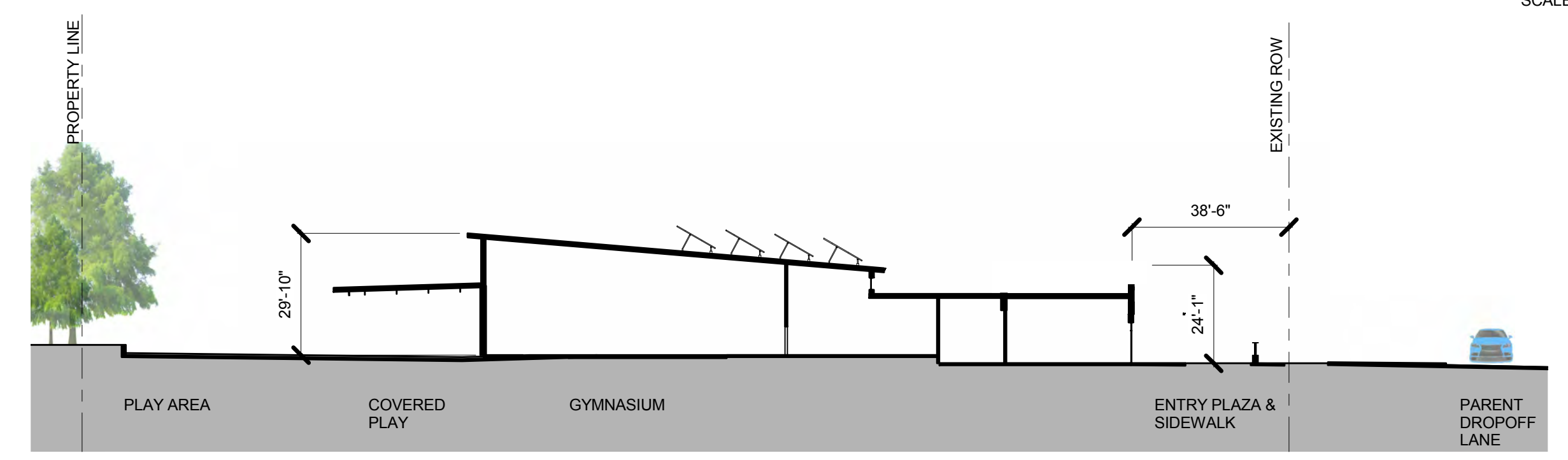

**SITE SECTION 2**  
 SCALE: 1" = 30'-0"

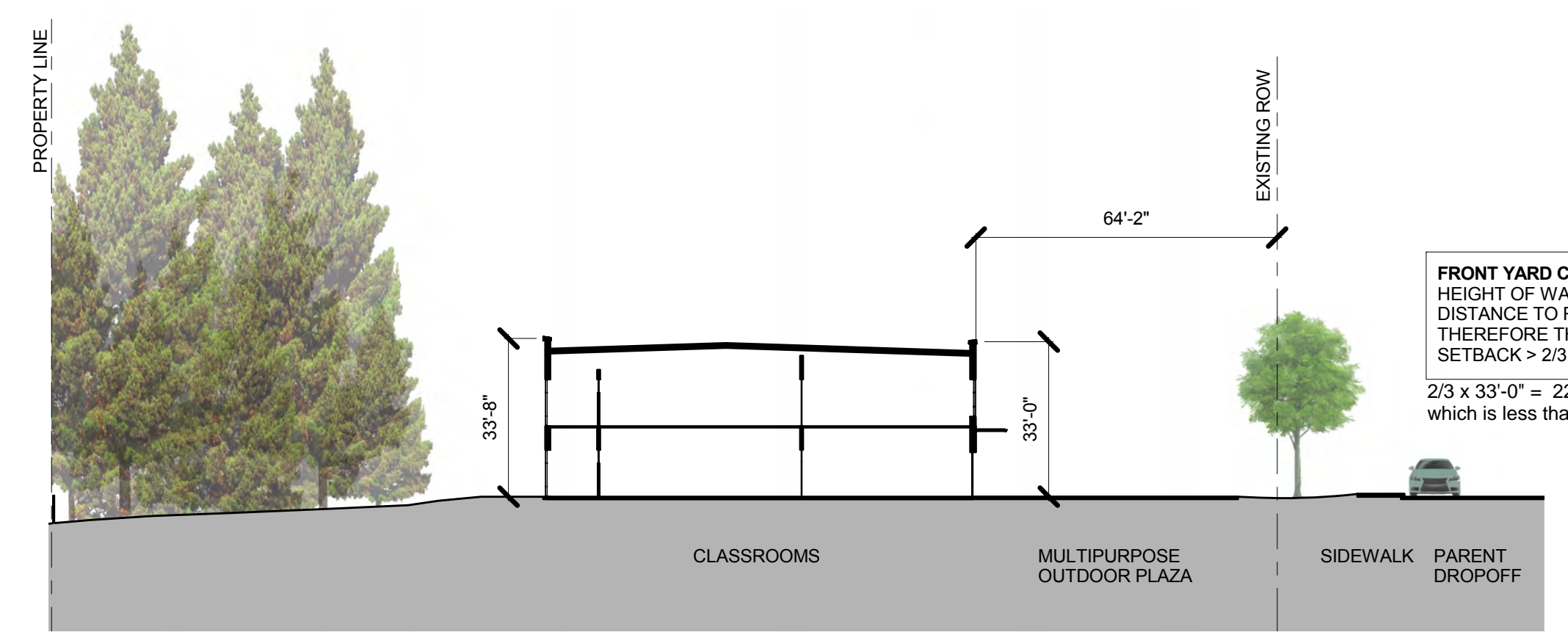

**SITE SECTION 1**  
 SCALE: 1" = 30'-0"

**FRONT YARD CALCULATION:**  
 HEIGHT OF WALL IS 33'-0"  
 DISTANCE TO ROW IS 64'-2"  
 THEREFORE THE FRONT YARD  
 SETBACK > 2/3 BUILDING HEIGHT.  
 $2/3 \times 33'-0" = 22'-0"$   
 which is less than 64'-2"

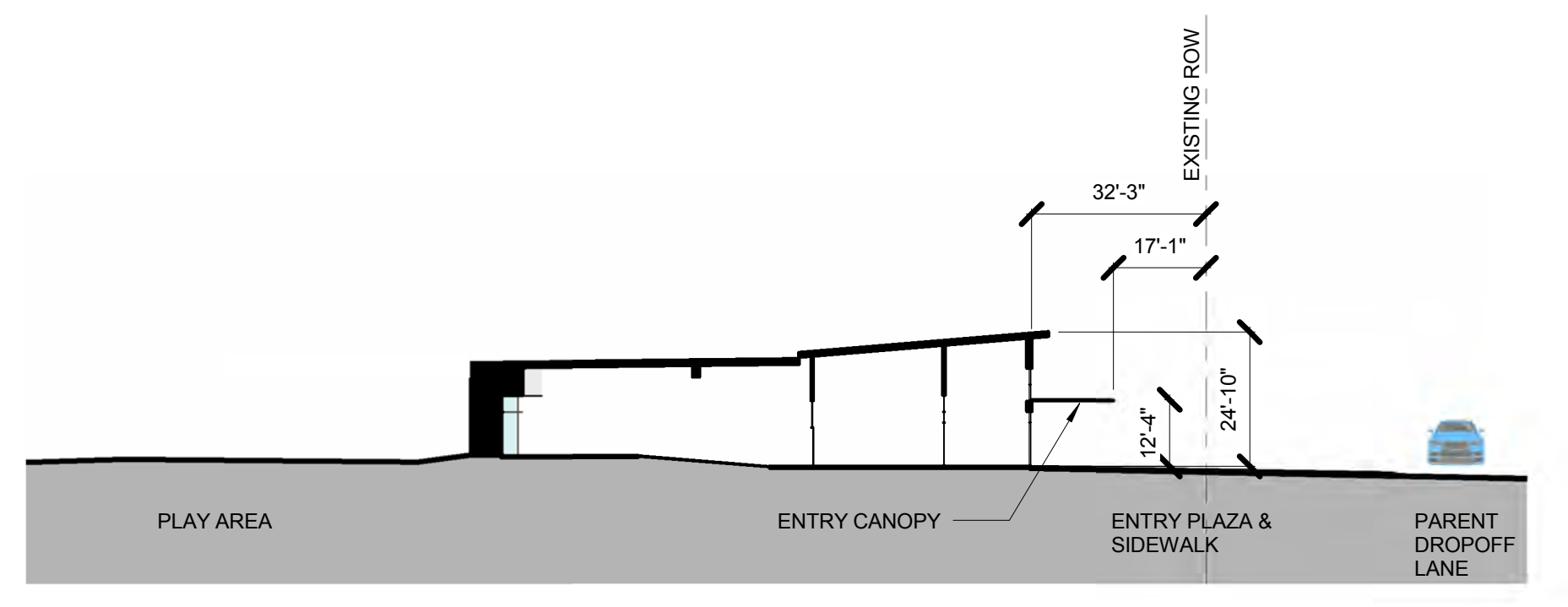

**SITE SECTION 8**  
 SCALE: 1" = 30'-0"

**FRONT YARD CALCULATION:**  
 $2/3 \times 24'-10" = +/- 16'-8"$   
 which is less than 32'-3"  
 THEREFORE THE FRONT YARD  
 SETBACK > 2/3 BUILDING HEIGHT.

**FRONT YARD CALCULATION:**  
 $2/3 \times 12'-4" = +/- 8'-3"$   
 which is less than 17'-1"  
 THEREFORE THE FRONT YARD  
 SETBACK > 2/3 BUILDING HEIGHT.

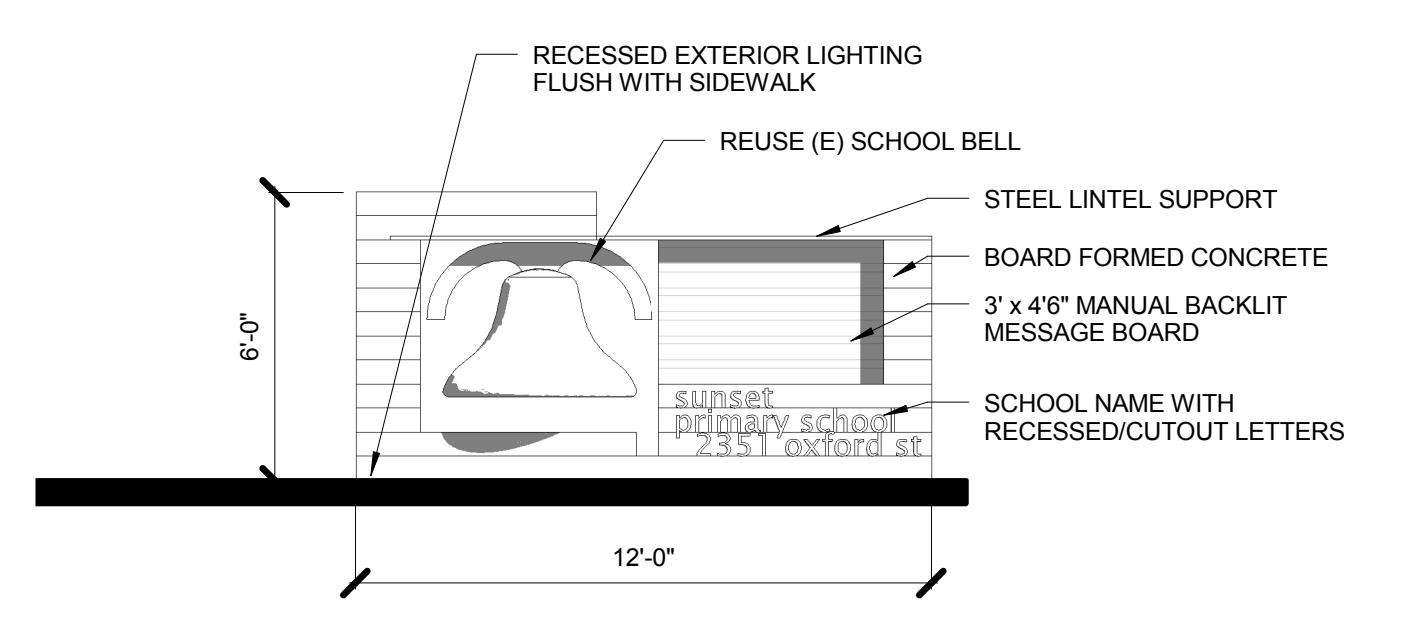

**ENTRY SIGN 7**  
 SCALE: 1/4" = 1'-0"

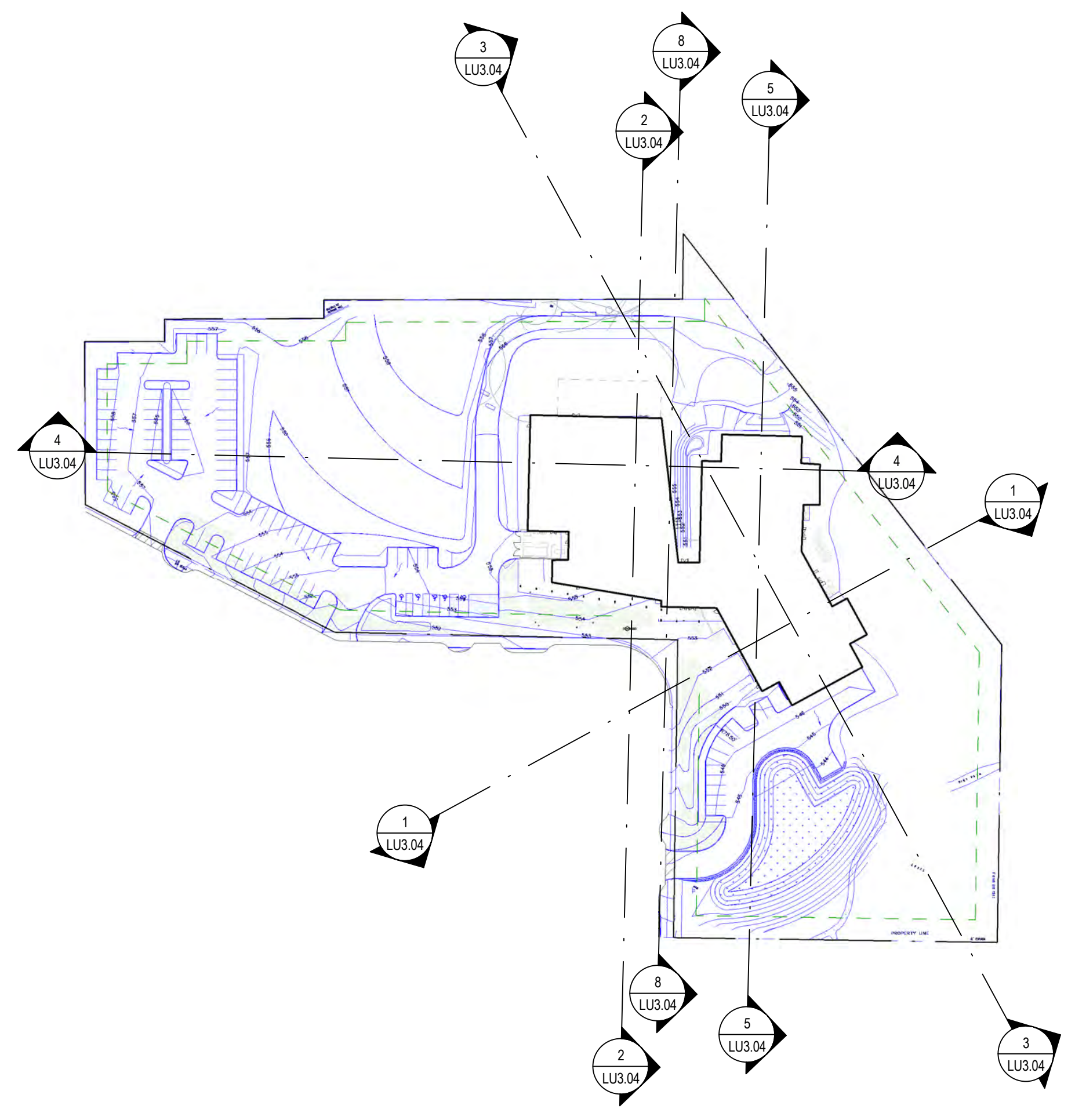

**SITE PLAN SECTION CUTS 6**  
 SCALE: 1" = 100'-0"

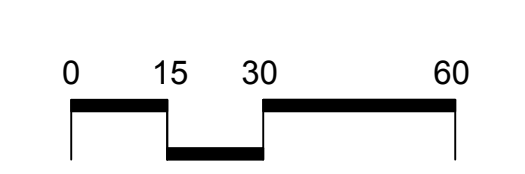

1/6/2016 12:04:13 PM  
 J:\15015\_Sunset\PS\Repl\15.3 Approvals - Code & AHJ.Landuse Dwg\16-0108 Completeness Resubmit\ARCH Revit  
 model\ARCH\_SPS.rvt



## BRICK VENEER

BV-1: MOUNTAIN BLEND w/MISSION TEXTURE  
FIELD BRICK

BV-2: MAUNA LOA w/MISSION TEXTURE  
LEVEL 1 AND BELOW

WALL BASE BELOW WINDOW AT WOOD SIDING CORNER



FIBER CEMENT SIDING - MAPLE FINISH

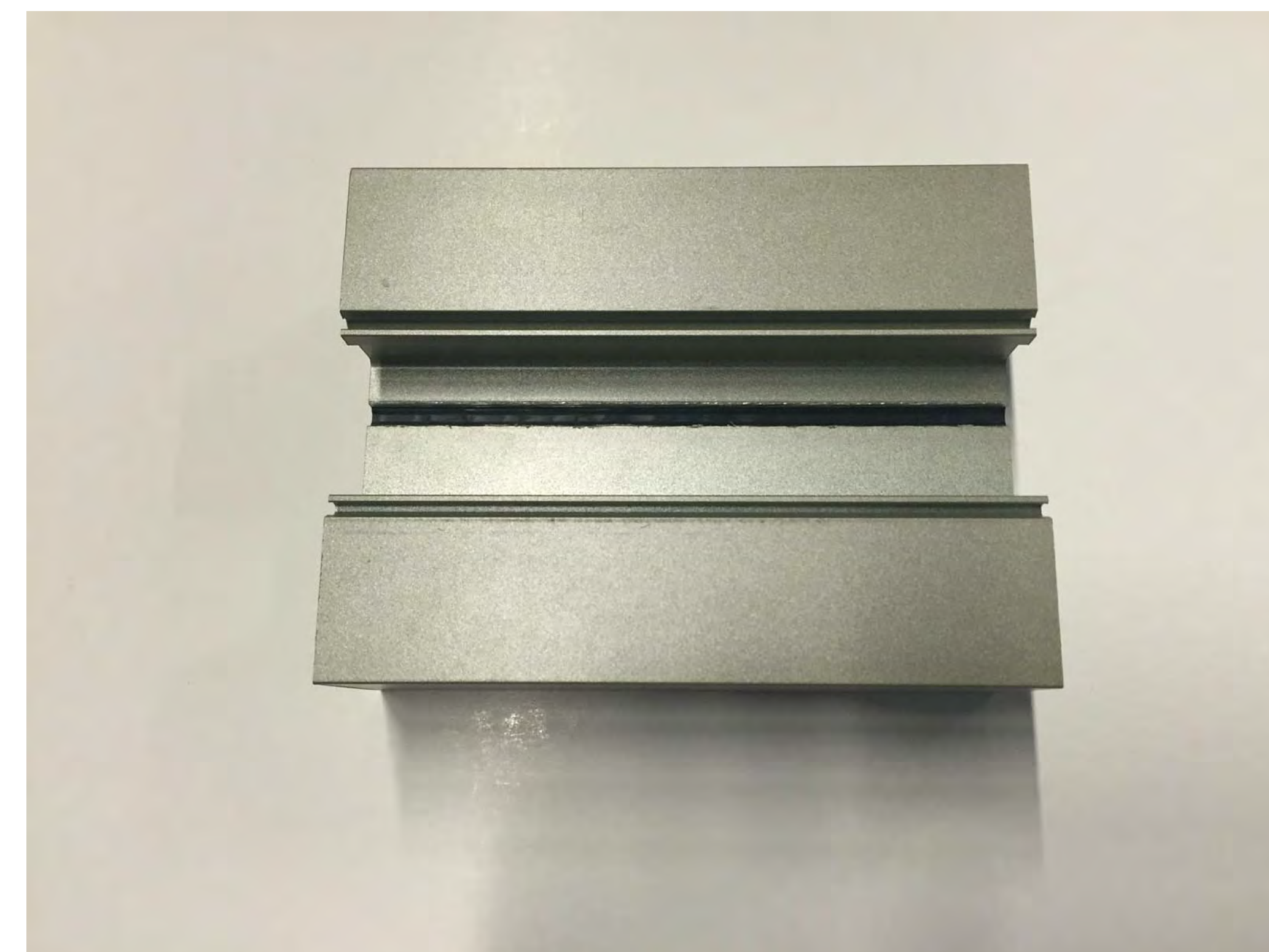

CURTAIN WALL / STOREFRONT  
CHAMPAGNE - EFCO / KAWNEER

2/19/2016 2:28:10 PM C:\Users\ken.riddle\Documents\15015\_Sunset\_PS\_CENTRAL\_ken.riddle.rvt



WEST LINN WILSONVILLE

2755 SW Borland Road  
Tualatin, OR 97062  
(503) 673-7995



Dull Olson Weekes - IBI Group  
Architects, Inc.

907 SW Stark Street Portland OR 97205 USA  
tel: 503 226 6950 fax: 503 273 9192  
www.dowa-ibigroup.com www.ibigroup.com

SUNSET REVISIONING  
West Linn - Wilsonville School District  
2351 Oxford St, West Linn, OR 97068  
t: (503) 673-7988

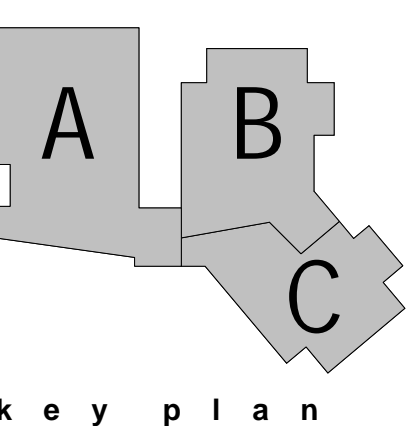

key plan

phase | LAND USE

date | November 13, 2015

revisions | January 8, 2016

February 22, 2016

project # | 15015

EXTERIOR MATERIALS

**LU3.05**

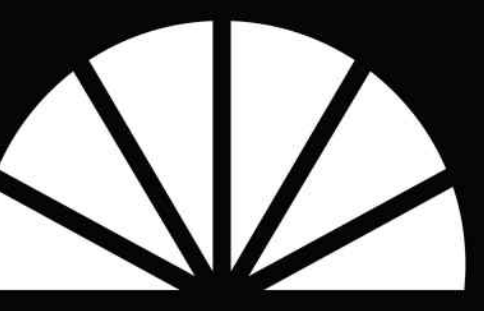

WEST LINN WILSONVILLE  
 2755 SW Borland Road  
 Tualatin, OR 97062  
 (503) 673 7995



Dull Olson Weekes - IBI Group  
 Architects, Inc.

907 SW Stark Street Portland OR 97205 USA  
 tel: 503 226 6950 fax: 503 273 9192  
 www.dowe-ibigroup.com www.ibigroup.com



Portland | San Francisco | Seattle  
 pae-engineers.com

**GENERAL NOTES:**  
 A. REFER TO PGE DRAWING '1L-1' FOR STREET LIGHTING DESIGN.

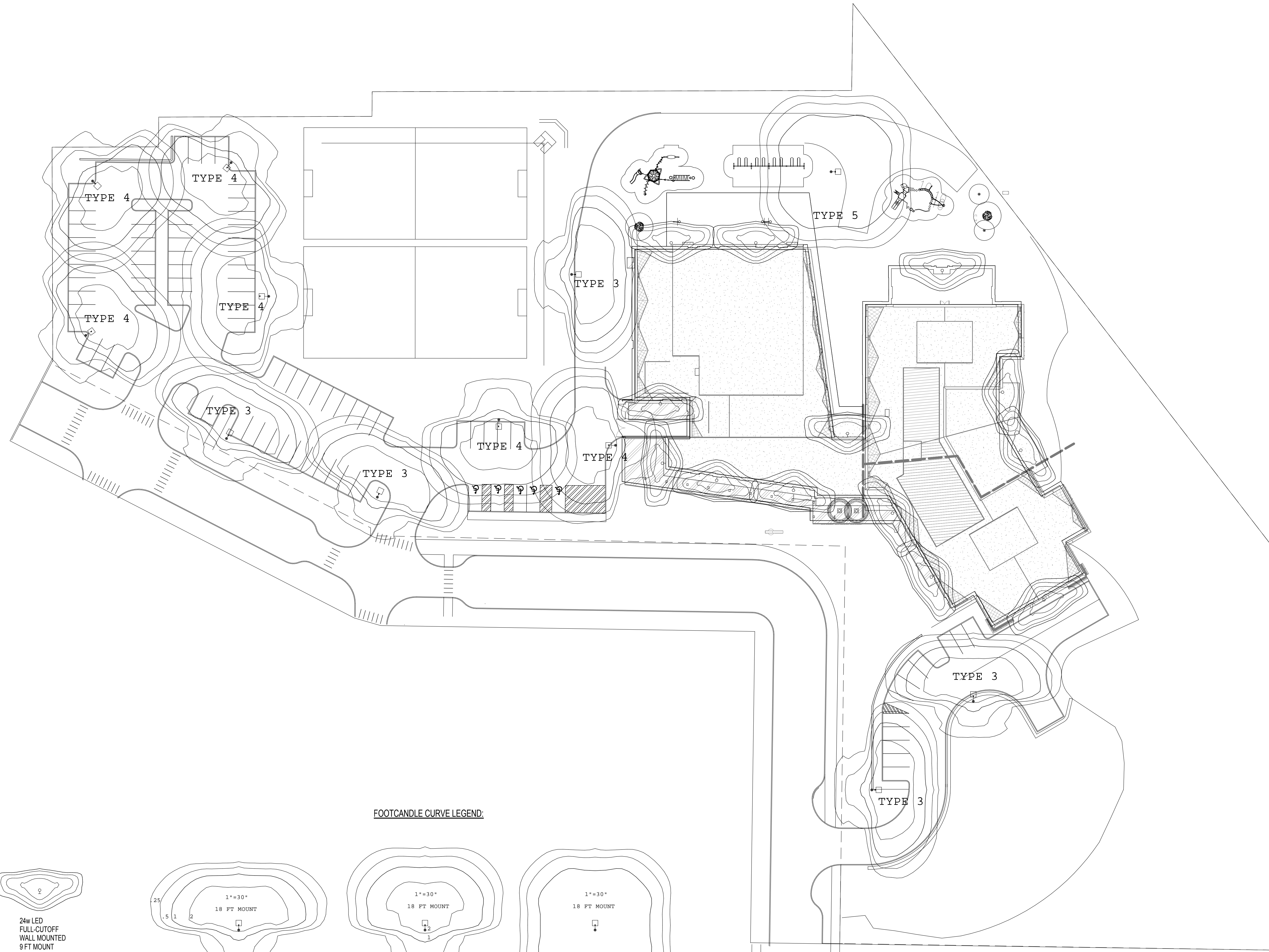

**FOOTCANDLE CURVE LEGEND:**

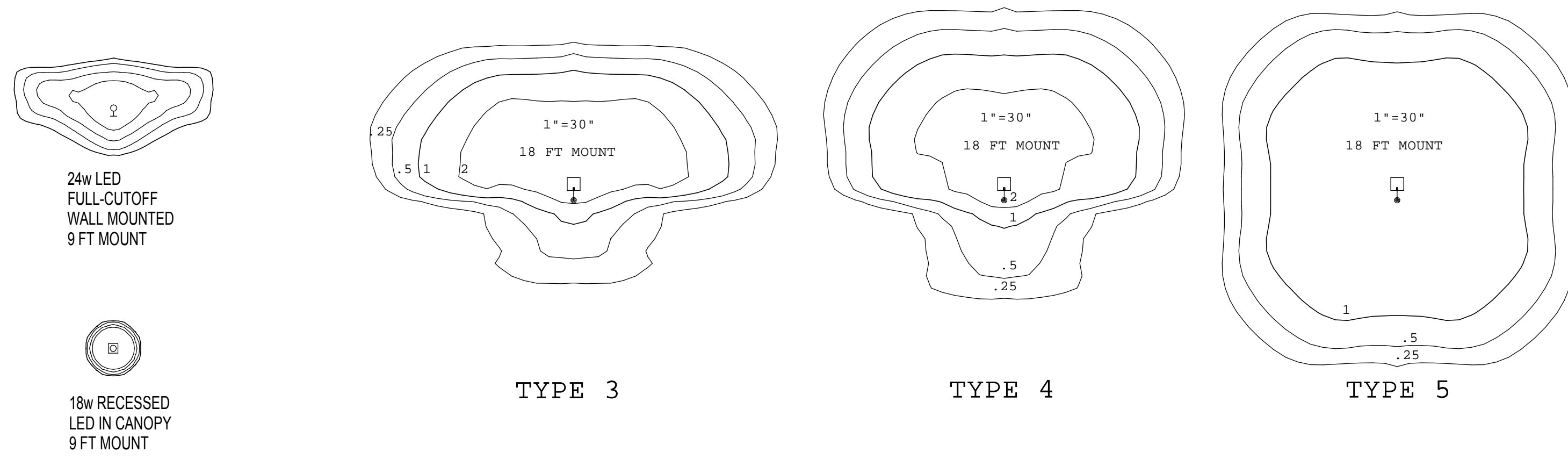

2 LIGHT COVERAGE PLAN - LAND USE  
 1" = 30'-0"

1/6/2016 10:10:00 AM  
 C:\rent\Local Files\15-1290 MEP\1515-1290 MEP\15\_samuel.aubenthal.rvt

**SUNSET REVISIONING**  
 West Linn - Wilsonville School District  
 2351 Oxford St, West Linn, OR 97068  
 t: (503) 673-7988

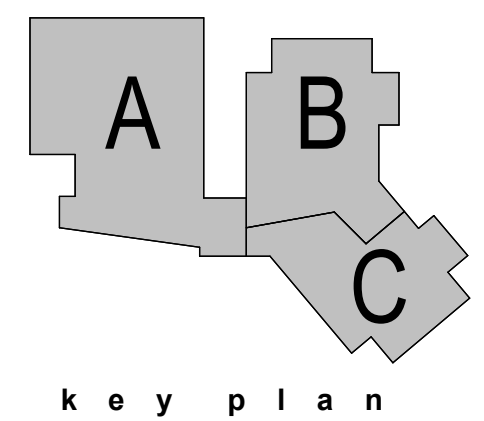

phase	LAND USE
date	November 13, 2015
revisions	January 8, 2016

project # 15015  
 LIGHT COVERAGE PLAN

**LU4.01**

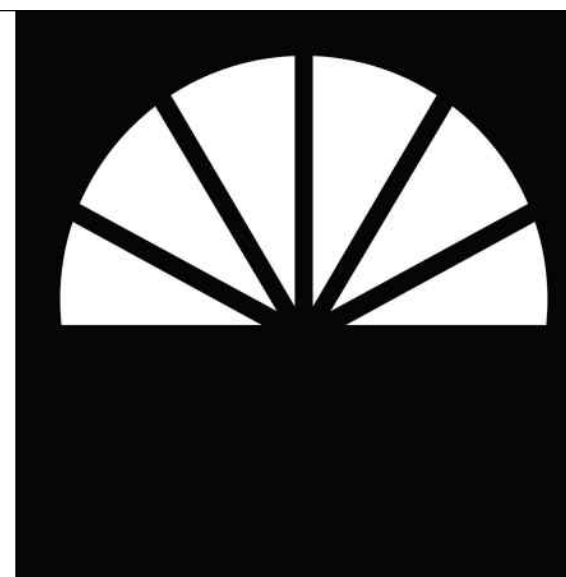

WEST LINN WILSONVILLE  
 2755 SW Borland Road  
 Tualatin, OR 97062  
 (503) 673 7995

**hova** | **IBI GROUP**  
 Dull Olson Weekes - IBI Group  
 Architects, Inc.  
 907 SW Stark Street Portland OR 97205 USA  
 tel: 503 226 6950 fax: 503 273 9192  
 www.dowe-ibigroup.com www.ibigroup.com

**PAE**  
 Portland | San Francisco | Seattle  
 pae-engineers.com

**SUNSET REVISIONING**  
 West Linn - Wilsonville School District  
 2351 Oxford St, West Linn, OR 97068  
 t: (503) 673-7988

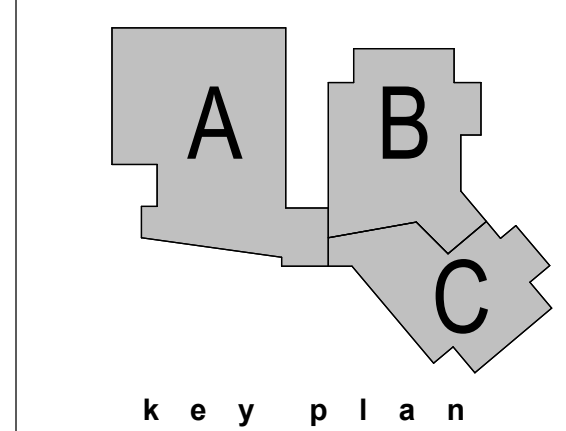

phase | LAND USE  
 date | November 13, 2015  
 revisions | January 8, 2016

project # | 15015  
 PGE STREET LIGHTING  
 PLAN

**LU4.02**

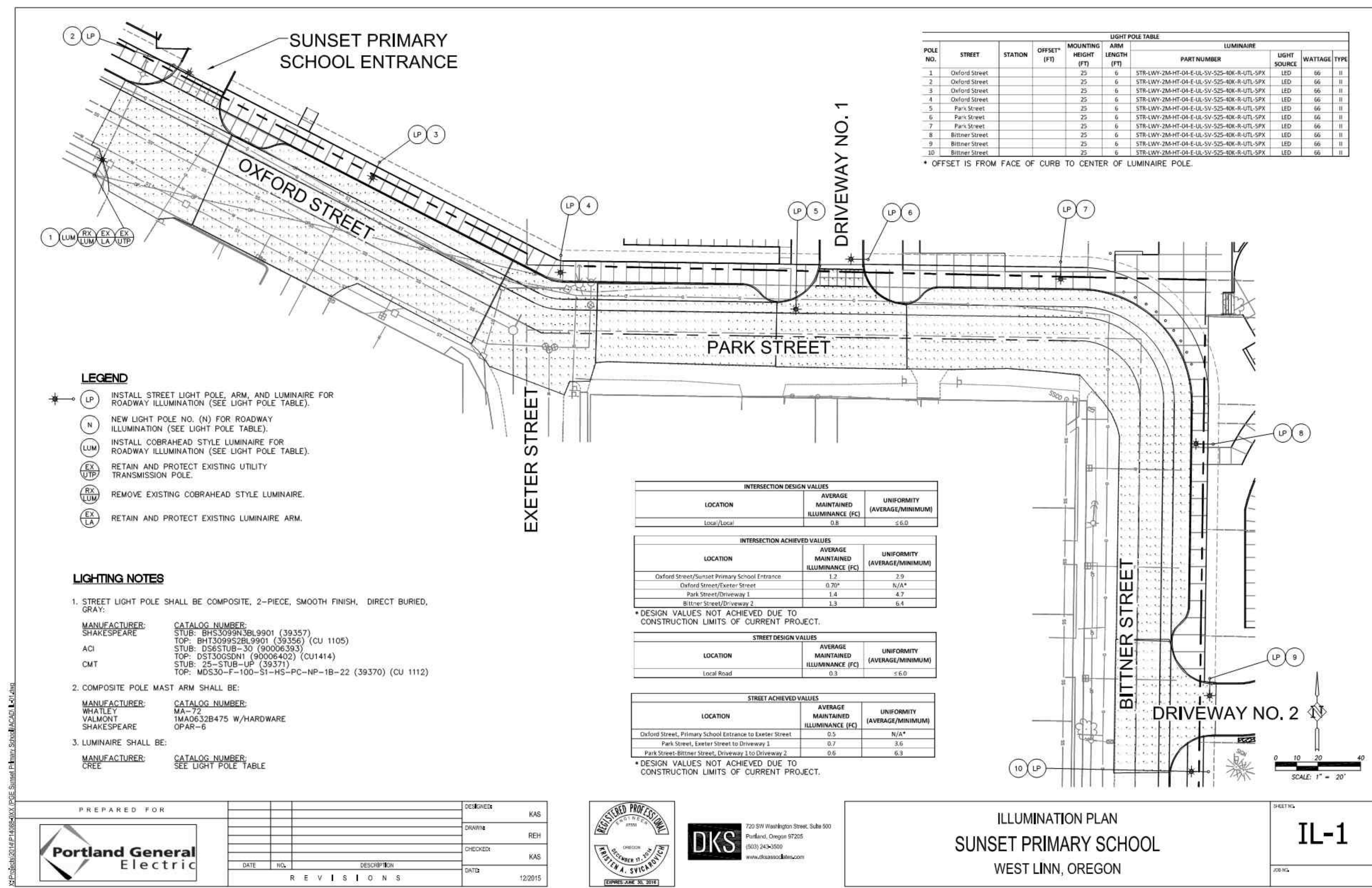

PREPARED FOR

DESIGNED BY	KAS
DRAWN BY	REH
CHECKED BY	KAS
DATE	12/2015

REVISIONS

NO.	DESCRIPTION	DATE

**REGISTERED PROFESSIONAL**  
**DKS**  
 720 SW Washington Street, Suite 500  
 Portland, Oregon 97205  
 (503) 244-3500  
 www.dksinc.com

ILLUMINATION PLAN  
 SUNSET PRIMARY SCHOOL  
 WEST LINN, OREGON

IL-1

1/6/2016 10:10:04 AM  
 C:\Rent\Local Files\15-1290 MEP\1515-1290 MEP\15\_samuel.taubenthal.rvt



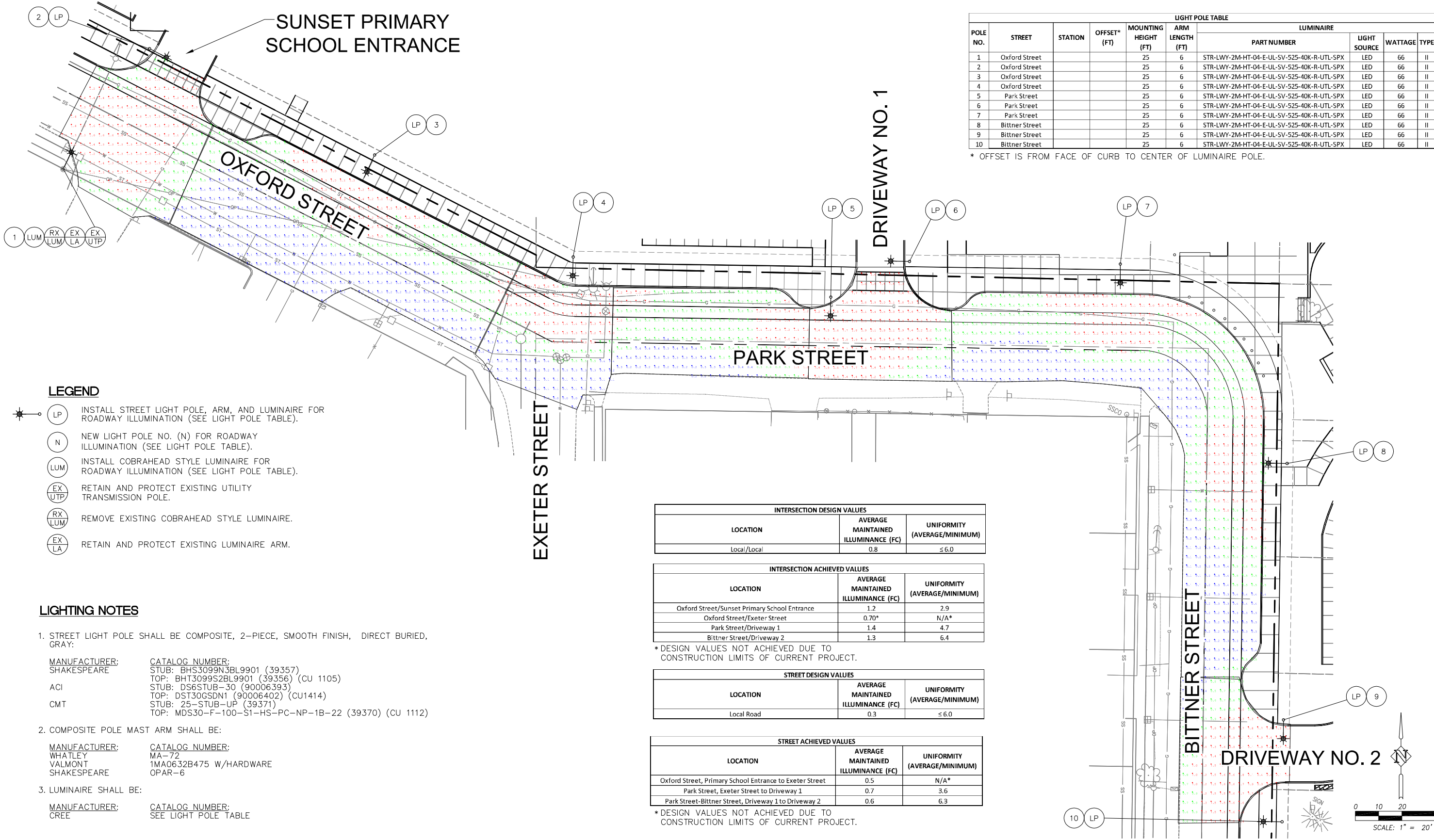

POLE NO.	STREET	STATION	OFFSET* (FT)	MOUNTING HEIGHT (FT)	ARM LENGTH (FT)	LUMINAIRE			
						PART NUMBER	LIGHT SOURCE	WATTAGE	TYPE
1	Oxford Street			25	6	STR-LWY-2M-HT-04-E-UL-SV-525-40K-R-UTL-SPX	LED	66	II
2	Oxford Street			25	6	STR-LWY-2M-HT-04-E-UL-SV-525-40K-R-UTL-SPX	LED	66	II
3	Oxford Street			25	6	STR-LWY-2M-HT-04-E-UL-SV-525-40K-R-UTL-SPX	LED	66	II
4	Oxford Street			25	6	STR-LWY-2M-HT-04-E-UL-SV-525-40K-R-UTL-SPX	LED	66	II
5	Park Street			25	6	STR-LWY-2M-HT-04-E-UL-SV-525-40K-R-UTL-SPX	LED	66	II
6	Park Street			25	6	STR-LWY-2M-HT-04-E-UL-SV-525-40K-R-UTL-SPX	LED	66	II
7	Park Street			25	6	STR-LWY-2M-HT-04-E-UL-SV-525-40K-R-UTL-SPX	LED	66	II
8	Bittner Street			25	6	STR-LWY-2M-HT-04-E-UL-SV-525-40K-R-UTL-SPX	LED	66	II
9	Bittner Street			25	6	STR-LWY-2M-HT-04-E-UL-SV-525-40K-R-UTL-SPX	LED	66	II
10	Bittner Street			25	6	STR-LWY-2M-HT-04-E-UL-SV-525-40K-R-UTL-SPX	LED	66	II

\* OFFSET IS FROM FACE OF CURB TO CENTER OF LUMINAIRE POLE.

**LEGEND**

- INSTALL STREET LIGHT POLE, ARM, AND LUMINAIRE FOR ROADWAY ILLUMINATION (SEE LIGHT POLE TABLE).
- NEW LIGHT POLE NO. (N) FOR ROADWAY ILLUMINATION (SEE LIGHT POLE TABLE).
- INSTALL COBRAHEAD STYLE LUMINAIRE FOR ROADWAY ILLUMINATION (SEE LIGHT POLE TABLE).
- RETAIN AND PROTECT EXISTING UTILITY TRANSMISSION POLE.
- REMOVE EXISTING COBRAHEAD STYLE LUMINAIRE.
- RETAIN AND PROTECT EXISTING LUMINAIRE ARM.

**LIGHTING NOTES**

- STREET LIGHT POLE SHALL BE COMPOSITE, 2-PIECE, SMOOTH FINISH, DIRECT BURIED, GRAY:
 

MANUFACTURER:	SHAKESPEARE	CATALOG NUMBER:	STUB: BHS3099N3BL9901 (39357)
			TOP: BHT3099S2BL9901 (39356) (CU 1105)
ACI			STUB: DS6STUB-30 (90006393)
CMT			TOP: DST30GSDN1 (90006402) (CU1414)
			STUB: 25-STUB-UP (39371)
			TOP: MDS30-F-100-S1-HS-PC-NP-1B-22 (39370) (CU 1112)
- COMPOSITE POLE MAST ARM SHALL BE:
 

MANUFACTURER:	WHATLEY	CATALOG NUMBER:	MA-72
	VALMONT		1MA0632B475 W/HARDWARE
	SHAKESPEARE		OPAR-6
- LUMINAIRE SHALL BE:
 

MANUFACTURER:	CREE	CATALOG NUMBER:	SEE LIGHT POLE TABLE
---------------	------	-----------------	----------------------

INTERSECTION DESIGN VALUES		
LOCATION	AVERAGE MAINTAINED ILLUMINANCE (FC)	UNIFORMITY (AVERAGE/MINIMUM)
Local/Local	0.8	≤ 6.0

INTERSECTION ACHIEVED VALUES		
LOCATION	AVERAGE MAINTAINED ILLUMINANCE (FC)	UNIFORMITY (AVERAGE/MINIMUM)
Oxford Street/Sunset Primary School Entrance	1.2	2.9
Oxford Street/Exeter Street	0.70*	N/A*
Park Street/Driveway 1	1.4	4.7
Bittner Street/Driveway 2	1.3	6.4

\* DESIGN VALUES NOT ACHIEVED DUE TO CONSTRUCTION LIMITS OF CURRENT PROJECT.

STREET DESIGN VALUES		
LOCATION	AVERAGE MAINTAINED ILLUMINANCE (FC)	UNIFORMITY (AVERAGE/MINIMUM)
Local Road	0.3	≤ 6.0

STREET ACHIEVED VALUES		
LOCATION	AVERAGE MAINTAINED ILLUMINANCE (FC)	UNIFORMITY (AVERAGE/MINIMUM)
Oxford Street, Primary School Entrance to Exeter Street	0.5	N/A*
Park Street, Exeter Street to Driveway 1	0.7	3.6
Park Street-Bittner Street, Driveway 1 to Driveway 2	0.6	6.3

\* DESIGN VALUES NOT ACHIEVED DUE TO CONSTRUCTION LIMITS OF CURRENT PROJECT.

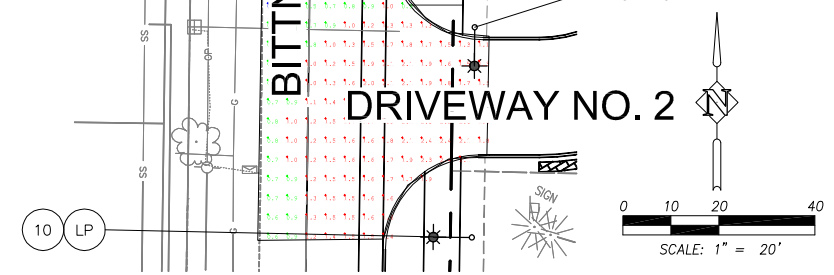

X:\Projects\2014\1P\4088-0X\FGE Sunset Primary School\ACAD\IL-01.dwg

PREPARED FOR		DESIGNED:	KAS
		DRAWN:	REH
		CHECKED:	KAS
		DATE:	12/2015
NO.	DESCRIPTION	REVISIONS	

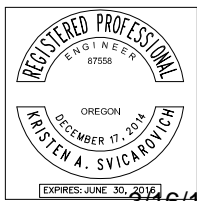

720 SW Washington Street, Suite 500  
 Portland, Oregon 97205  
 (503) 243-3500  
 www.dksassociates.com

**ILLUMINATION PLAN**  
**SUNSET PRIMARY SCHOOL**  
 WEST LINN, OREGON

SHEET NO.	<b>IL-1</b>
JOB NO.	

## PC-4 PUBLIC COMMENTS



December 9, 2015

Darren Wyss  
Associate Planner  
City of West Linn  
22500 Salamo Road  
West Linn, OR 97068

**Re: Sunset Primary School, CUP-15-03/DR-15-17/VAR-15-01/VAR-15-02/VAR-15-03**

**Tax Lot ID# 2S1 25DC / Lots: 600, 3700, 5800, 6300**

Dear Darren,

Thank you for the opportunity to review the proposed site plan surrounding the above named development project. Tualatin Valley Fire & Rescue endorses this proposal predicated on the following criteria and conditions of approval:

**FIRE APPARATUS ACCESS:**

- FIRE APPARATUS ACCESS ROAD DISTANCE FROM BUILDINGS AND FACILITIES:** Access roads shall be within 150 feet of all portions of the exterior wall of the first story of the building as measured by an approved route around the exterior of the building or facility. An approved turnaround is required if the remaining distance to an approved intersecting roadway, as measured along the fire apparatus access road, is greater than 150 feet. (OFC 503.1.1))
- FIRE APPARATUS ACCESS ROAD EXCEPTION FOR AUTOMATIC SPRINKLER PROTECTION:** When buildings are completely protected with an approved automatic fire sprinkler system, the requirements for fire apparatus access may be modified as approved by the fire code official. (OFC 503.1.1) **Note: If residential fire sprinklers are elected as an alternate means of protection and the system will be supported by a municipal water supply, please contact the local water purveyor for information surrounding water meter sizing.**
- ADDITIONAL ACCESS ROADS – COMMERCIAL/INDUSTRIAL HEIGHT:** Buildings exceeding 30 feet in height or three stories in height shall have at least two separate means of fire apparatus access. (D104.1)
- ADDITIONAL ACCESS ROADS – COMMERCIAL/INDUSTRIAL SQUARE FOOTAGE:** Buildings or facilities having a gross building area of more than 62,000 square feet shall have at least two approved separate means of fire apparatus access. Exception: Projects having a gross building area of up to 124,000 square feet that have a single approved fire apparatus access road when all buildings are equipped throughout with approved automatic sprinkler systems. (OFC D104.2)
- AERIAL FIRE APPARATUS ROADS:** Buildings with a vertical distance between the grade plane and the highest roof surface that exceeds 30 feet in height shall be provided with a fire apparatus access road constructed for use by aerial apparatus with an unobstructed driving surface width of not less than 26 feet. For the purposes of this section, the highest roof surface shall be determined by measurement to the eave

North Operating Center  
20665 SW Blanton Street  
Aloha, Oregon 97078  
503-649-8577

Command & Business Operations Center  
and Central Operating Center  
11945 SW 70<sup>th</sup> Avenue  
Tigard, Oregon 97223-9196  
503-649-8577

South Operating Center  
8445 SW Elligsen Road  
Wilsonville, Oregon  
97070-9641  
503-649-8577

Training Center  
12400 SW Tonquin Road  
Sherwood, Oregon  
97140-9734  
503-259-1600

of a pitched roof, the intersection of the roof to the exterior wall, or the top of the parapet walls, whichever is greater. Any portion of the building may be used for this measurement, provided that it is accessible to firefighters and is capable of supporting ground ladder placement. (OFC D105.1, D105.2)

6. **AERIAL APPARATUS OPERATIONS:** At least one of the required aerial access routes shall be located within a minimum of 15 feet and a maximum of 30 feet from the building, and shall be positioned parallel to one entire side of the building. The side of the building on which the aerial access road is positioned shall be approved by the fire code official. Overhead utility and power lines shall not be located over the aerial access road or between the aerial access road and the building. (D105.3, D105.4)
7. **MULTIPLE ACCESS ROADS SEPARATION:** Where two access roads are required, they shall be placed a distance apart equal to not less than one half of the length of the maximum overall diagonal dimension of the area to be served (as identified by the Fire Code Official), measured in a straight line between accesses. (OFC D104.3) Exception: Buildings equipped throughout with an approved automatic fire sprinkler system (the approval of this alternate method of construction shall be accomplished in accordance with the provisions of ORS 455.610(5)).
8. **FIRE APPARATUS ACCESS ROAD WIDTH AND VERTICAL CLEARANCE:** Fire apparatus access roads shall have an unobstructed driving surface width of not less than 20 feet (26 feet adjacent to fire hydrants (OFC D103.1)) and an unobstructed vertical clearance of not less than 13 feet 6 inches. The fire district will approve access roads of 12 feet for up to three dwelling units and accessory buildings. (OFC 503.2.1 & D103.1)
9. **NO PARKING SIGNS:** Where fire apparatus roadways are not of sufficient width to accommodate parked vehicles and 20 feet of unobstructed driving surface, "No Parking" signs shall be installed on one or both sides of the roadway and in turnarounds as needed. Signs shall read "NO PARKING - FIRE LANE" and shall be installed with a clear space above grade level of 7 feet. Signs shall be 12 inches wide by 18 inches high and shall have red letters on a white reflective background. (OFC D103.6)
10. **NO PARKING:** Parking on emergency access roads shall be as follows (OFC D103.6.1-2):
  1. 20-26 feet road width – no parking on either side of roadway
  2. 26-32 feet road width – parking is allowed on one side
  3. Greater than 32 feet road width – parking is not restricted
11. **PAINTED CURBS:** Where required, fire apparatus access roadway curbs shall be painted red (or as approved) and marked "NO PARKING FIRE LANE" at 25 foot intervals. Lettering shall have a stroke of not less than one inch wide by six inches high. Lettering shall be white on red background (or as approved). (OFC 503.3)
12. **FIRE APPARATUS ACCESS ROADS WITH FIRE HYDRANTS:** Where a fire hydrant is located on a fire apparatus access road, the minimum road width shall be 26 feet and shall extend 20 feet before and after the point of the hydrant. (OFC D103.1)
13. **TURNOUTS:** Where access roads are less than 20 feet and exceed 400 feet in length, turnouts 10 feet wide and 30 feet long may be required and will be determined on a case by case basis. (OFC 503.2.2)
14. **SURFACE AND LOAD CAPACITIES:** Fire apparatus access roads shall be of an all-weather surface that is easily distinguishable from the surrounding area and is capable of supporting not less than 12,500 pounds point load (wheel load) and 75,000 pounds live load (gross vehicle weight). Documentation from a

registered engineer that the final construction is in accordance with approved plans or the requirements of the Fire Code may be requested. (OFC 503.2.3)

15. **BRIDGES:** Private bridges shall be designed and constructed in accordance with the State of Oregon Department of Transportation and American Association of State Highway and Transportation Officials Standards *Standard Specification for Highway Bridges*. A building permit shall be obtained for the construction of the bridge if required by the building official of the jurisdiction where the bridge is to be built. The design engineer shall prepare a special inspection and structural observation program for approval by the building official. The design engineer shall give, in writing; final approval of the bridge to the fire district after construction is completed. Maintenance of the bridge shall be the responsibility of the party or parties that use the bridge for access to their property. The fire district may at any time, for due cause, ask that a registered engineer inspect the bridge for structural stability and soundness at the expense of the property owner(s) the bridge serves. (OFC 503.2.6)

16. **TURNING RADIUS:** The inside turning radius and outside turning radius shall not be less than 28 feet and 48 feet respectively, measured from the same center point. (OFC 503.2.4 & D103.3)

17. **ACCESS ROAD GRADE:** Fire apparatus access roadway grades shall not exceed 12%. When fire sprinklers\* are installed, a maximum grade of 15% will be allowed.

0-12%	Allowed
13-15%	Special consideration with submission of written Alternate Methods and Materials request. Ex: Automatic fire sprinkler (13-D) system* in lieu of grade.
16-18%	Special consideration on a case by case basis with submission of written Alternate Methods and Materials request Ex: Automatic fire sprinkler (13-D) system* plus additional engineering controls in lieu of grade.
Greater than 18%	Not allowed**

\*The approval of fire sprinklers as an alternate shall be accomplished in accordance with the provisions of ORS 455.610(5) and OAR 918-480-0100 and installed per section 903.3.1.1, 903.3.1.2, or 903.3.1.3 of the Oregon Fire Code (OFC 503.2.7 & D103.2)

18. **ANGLE OF APPROACH/GRADE FOR TURNAROUNDS:** Turnarounds shall be as flat as possible and have a maximum of 5% grade with the exception of crowning for water run-off. (OFC 503.2.7 & D103.2)

19. **ANGLE OF APPROACH/GRADE FOR INTERSECTIONS:** Intersections shall be level (maximum 5%) with the exception of crowning for water run-off. (OFC 503.2.7 & D103.2)

20. **AERIAL APPARATUS OPERATING GRADES:** Portions of aerial apparatus roads that will be used for aerial operations shall be as flat as possible. Front to rear and side to side maximum slope shall not exceed 10%.

21. **GATES:** Gates securing fire apparatus roads shall comply with all of the following (OFC D103.5, and 503.6):
1. Minimum unobstructed width shall be not less than 20 feet (or the required roadway surface width), or two 10 foot sections with a center post or island.
  2. Gates shall be set back at minimum of 30 feet from the intersecting roadway or as approved.
  3. Electric gates shall be equipped with a means for operation by fire department personnel
  4. Electric automatic gates shall comply with ASTM F 2200 and UL 325.

22. **ACCESS DURING CONSTRUCTION:** Approved fire apparatus access roadways shall be installed and operational prior to any combustible construction or storage of combustible materials on the site. Temporary address signage shall also be provided during construction. (OFC 3309 and 3310.1)
23. **TRAFFIC CALMING DEVICES:** Shall be prohibited on fire access routes unless approved by the Fire Code Official. See Application Guide Appendix A for further information. (OFC 503.4.1).

## **FIREFIGHTING WATER SUPPLIES:**

24. **MUNICIPAL FIREFIGHTING WATER SUPPLY EXCEPTIONS:** The requirements for firefighting water supplies may be modified as approved by the fire code official where any of the following apply: (OFC 507.5.1 Exceptions)
  1. Buildings are equipped throughout with an approved automatic fire sprinkler system (the approval of this alternate method of construction shall be accomplished in accordance with the provisions of ORS 455.610(5)).
  2. There are not more than three Group R-3 or Group U occupancies.
25. **COMMERCIAL BUILDINGS – REQUIRED FIRE FLOW:** The minimum fire flow and flow duration for buildings other than one- and two-family dwellings shall be determined in accordance with residual pressure (OFC Table B105.2). The required fire flow for a building shall not exceed the available GPM in the water delivery system at 20 psi.
 

**Note:** OFC B106, Limiting Fire-Flow is also enforced, except for the following:

  - In areas where the water system is already developed, the maximum needed fire flow shall be either 3,000 GPM or the available flow in the system at 20 psi, whichever is greater.
  - In new developed areas, the maximum needed fire flow shall be 3,000 GPM at 20 psi.
  - Tualatin Valley Fire & Rescue does not adopt Occupancy Hazards Modifiers in section B105.4-B105.4.1
26. **FIRE FLOW WATER AVAILABILITY:** Applicants shall provide documentation of a fire hydrant flow test or flow test modeling of water availability from the local water purveyor if the project includes a new structure or increase in the floor area of an existing structure. Tests shall be conducted from a fire hydrant within 400 feet for commercial projects, or 600 feet for residential development. Flow tests will be accepted if they were performed within 5 years as long as no adverse modifications have been made to the supply system. Water availability information may not be required to be submitted for every project. (OFC Appendix B)
27. **WATER SUPPLY DURING CONSTRUCTION:** Approved firefighting water supplies shall be installed and operational prior to any combustible construction or storage of combustible materials on the site. (OFC 3312.1)

## **FIRE HYDRANTS:**

28. **FIRE HYDRANTS – COMMERCIAL BUILDINGS:** Where a portion of the building is more than 400 feet from a hydrant on a fire apparatus access road, as measured in an approved route around the exterior of the building, on-site fire hydrants and mains shall be provided. (OFC 507.5.1)
  - This distance may be increased to 600 feet for buildings equipped throughout with an approved automatic sprinkler system.
  - The number and distribution of fire hydrants required for commercial structure(s) is based on Table C105.1, following any fire-flow reductions allowed by section B105.3.1. Additional fire hydrants may be required due to spacing and/or section 507.5 of the Oregon Fire Code.

29. **FIRE HYDRANT NUMBER AND DISTRIBUTION:** The minimum number and distribution of fire hydrants available to a building shall not be less than that listed in Table C 105.1. (OFC Appendix C)
30. **FIRE HYDRANT(S) PLACEMENT:** (OFC C104)
- Existing hydrants in the area may be used to meet the required number of hydrants as approved. Hydrants that are up to 600 feet away from the nearest point of a subject building that is protected with fire sprinklers may contribute to the required number of hydrants. (OFC 507.5.1)
  - Hydrants that are separated from the subject building by railroad tracks shall not contribute to the required number of hydrants unless approved by the fire code official.
  - Hydrants that are separated from the subject building by divided highways or freeways shall not contribute to the required number of hydrants. Heavily traveled collector streets may be considered when approved by the fire code official.
  - Hydrants that are accessible only by a bridge shall be acceptable to contribute to the required number of hydrants only if approved by the fire code official.
31. **PRIVATE FIRE HYDRANT IDENTIFICATION:** Private fire hydrants shall be painted red in color. Exception: Private fire hydrants within the City of Tualatin shall be yellow in color. (OFC 507)
32. **FIRE HYDRANT DISTANCE FROM AN ACCESS ROAD:** Fire hydrants shall be located not more than 15 feet from an approved fire apparatus access roadway unless approved by the fire code official. (OFC C102.1)
33. **REFLECTIVE HYDRANT MARKERS:** Fire hydrant locations shall be identified by the installation of blue reflective markers. They shall be located adjacent and to the side of the center line of the access roadway that the fire hydrant is located on. In the case that there is no center line, then assume a center line and place the reflectors accordingly. (OFC 507)
34. **PHYSICAL PROTECTION:** Where fire hydrants are subject to impact by a motor vehicle, guard posts, bollards or other approved means of protection shall be provided. (OFC 507.5.6 & OFC 312)
35. **CLEAR SPACE AROUND FIRE HYDRANTS:** A 3 foot clear space shall be provided around the circumference of fire hydrants. (OFC 507.5.5)
36. **FIRE DEPARTMENT CONNECTION (FDC) LOCATIONS:** FDCs shall be located within 100 feet of a fire hydrant (or as approved). Hydrants and FDC's shall be located on the same side of the fire apparatus access roadway or drive aisle, fully visible, and recognizable from the street or nearest point of the fire department vehicle access or as otherwise approved. (OFC 912.2.1 & NFPA 13)
- Fire department connections (FDCs) shall normally be located remotely and outside of the fall-line of the building when required. FDCs may be mounted on the building they serve, when approved.
  - FDCs shall be plumbed on the system side of the check valve when sprinklers are served by underground lines also serving private fire hydrants.

## BUILDING ACCESS AND FIRE SERVICE FEATURES

37. **EMERGENCY RESPONDER RADIO COVERAGE:** In new buildings where the design reduces the level of radio coverage for public safety communications systems below minimum performance levels, a distributed antenna system, signal booster, or other method approved by TVF&R and Washington County Consolidated Communications Agency shall be provided. (OFC 510.1)

5

38. **KNOX BOX:** A Knox Box for building access may be required for structures and gates. See Appendix C for further information and detail on required installations. Order via [www.tvfr.com](http://www.tvfr.com) or contact TVF&R for assistance and instructions regarding installation and placement. (OFC 506.1)
39. **UTILITY IDENTIFICATION:** Rooms containing controls to fire suppression and detection equipment shall be identified as "Fire Control Room." Signage shall have letters with a minimum of 4 inches high with a minimum stroke width of 1/2 inch, and be plainly legible, and contrast with its background. (OFC 509.1)

If you have questions or need further clarification, please feel free to contact me at (503) 649-8577.

Sincerely,



Ty Darby  
Deputy Fire Marshal II

Cc: file



West Linn Planning Commission  
West Linn City Hall  
22500 Salamo Road  
West Linn, OR 97068

Feb. 27, 2016



Re: Sunset Elementary School Plans

Dear Commissioners,

I am writing to you regarding the plans for building a new school building for the students at Sunset Elementary School. While I, like my neighbors, want a new school building for the students who live in Sunset neighborhood, it is important that it fit well into the community as the current one has. Sunset Park has been a place where people of all ages gather daily in a beautiful natural environment, participate in outdoor activities or social events, and children build physical skills and friendships among the play structures. It is a significant part of the ambiance and cohesiveness of our neighborhood. I believe we all want to maintain that sense of cohesive community and it would be helpful and relevant for the school to continue to be a part of it.

Certain factors in the current plan, as I understand it, threaten the safety of residents and continuity of cooperation between school and neighborhood. Originally we were told that the portion of Sunset Park adjacent to the school would become part of its playground. Now, the plans show that that area will become a parking lot and bio-swell, and will require the destruction of a large number of trees while being an ongoing threat to others. To me, the bio-swell seems a dangerous replacement for a children's play structure and a beautiful natural environment. It will undermine the integrity of the area and put other trees and private property at risk, an encroachment beyond the confines of the school. Since this school includes many children who walk to school, often through the park, these features seem an impediment to their safe arrival and departure from their learning environment. I feel (1) the bio-swell should be removed from the plan, while keeping more of the trees, and (2) re-evaluate the needed number of parking spaces for the school based on the number of children who walk instead of ride buses to school.

Despite meetings with neighbors and the school, I feel that for the most part the suggestions and concerns of the neighborhood have not been considered with a spirit of heart-felt cooperation. I have not seen that the ideas and requests from my neighbors have influenced the school plans in any notable, constructive way. I don't know how the decisions are being made for the new school, but I am sorry to say that there is a lack of evidence of working jointly with the citizens and voters in the neighborhood. Thus, the process for planning for Sunset School's new building has brought divisiveness rather than cohesiveness. This pattern is great loss for our neighborhood. I am hoping that this review by the West Linn Planning Commission will show a commitment to protect the safety and ambience of our neighborhood and provide leadership for rebuilding cohesiveness within our community, school and neighborhood. Thank you.

Sincerely,

  
Nancy Lamb, 4666 Bittner St., West Linn, OR 97068

**Wyss, Darren**

---

**From:** [REDACTED]  
**Sent:** Thursday, March 03, 2016 1:29 PM  
**To:** Wyss, Darren  
**Subject:** Sunset Park/School

Darren,

I saw your email on a Sunset Community thread and wanted to express my approval for the new school and plans for the park. As someone who walks through the park every day, and who's son attends the school, I believe that the plans prepared are well thought out and make the best compromises for our entire community. My only hope is that a few loud people cannot disrupt the new school construction because that school needs desperate repair.

Thank you for taking the time to read my email. I look forward to the new school and positive impact on my community.

Kindest Regards,

Elise Rogers  
Neighboring resident  
Oregon City Blvd

**Wyss, Darren**

---

**From:** [REDACTED]  
**Sent:** Thursday, March 03, 2016 2:34 PM  
**To:** Wyss, Darren  
**Subject:** Sunset Park/School Build

My family and I have been a member of the Sunset community for over 3 years. Our 8 year old son attends Sunset Primary. My wife and I have attended several of the meetings regarding the new school proposals. I know that people have an emotional attachment to Sunset Park as it currently exists and this is what comes out the loudest at these meetings. I have taken careful note of how the new property will affect not only my own property but the surrounding area. The school will now be in the sight line from my kitchen window. However, having a top-notch primary school for my son to attend, takes precedent. Also, the renderings that I see of the school and the property are much nicer than the current state of the property as it stands now. I am in full support of the plans to move forward with the building of the school per the proposed plans.

**Justin Rogers**

[REDACTED]  
[REDACTED]  
[REDACTED]  
[REDACTED]  
[REDACTED]

**PC-5 APPLICANT MEMORANDUM ADDRESSING CDC 46.120**

March 2, 2016

Darren Wyss, Associate Planner  
West Linn Planning Department  
22500 Salamo Road  
West Linn, OR 97068

RE: Sunset Primary School (CUP-15-03/DR-15-17/VAR-15-01/VAR-15-02/VAR-15-03)  
Site Plan Clarification RE: CDC 46.120 Driveway Required On Site

Dear Mr. Wyss,

During the staff review of the above application, the question was raised about how the proposed site plan complies with Community Development Code Section 46.120, which applies to schools and other facilities intended to accommodate more than 25 people at one time to "provide a 15-foot-wide driveway designed for continuous forward flow of passenger vehicles for the purpose of loading and unloading passengers."

This driveway for loading and unloading is provided, but the plan sheets do not specifically identify it as such. In order to clarify the district's intent regarding on-site loading and unloading, a site plan detail, which corresponds with Sheet LU1.02 of the application, is provided with supplemental notes to indicate how this function would be accommodated. The provisions of CDC 46.120 will be satisfied by:

- Vehicle entry via the driveway across from Exeter Street,
- Continuous forward flow on a 24-foot wide driveway for passenger vehicles to load/unload passengers, and
- Vehicle exiting via the western driveway across from Sussex Street.

Sincerely,



Keith S. Liden, AICP  
Consulting Planner for the District

cc: Remo Douglas, WLWV School District  
Tim Woodley, WLWV School District  
Mark Wharry, KPFF

46.120 CLARIFICATION

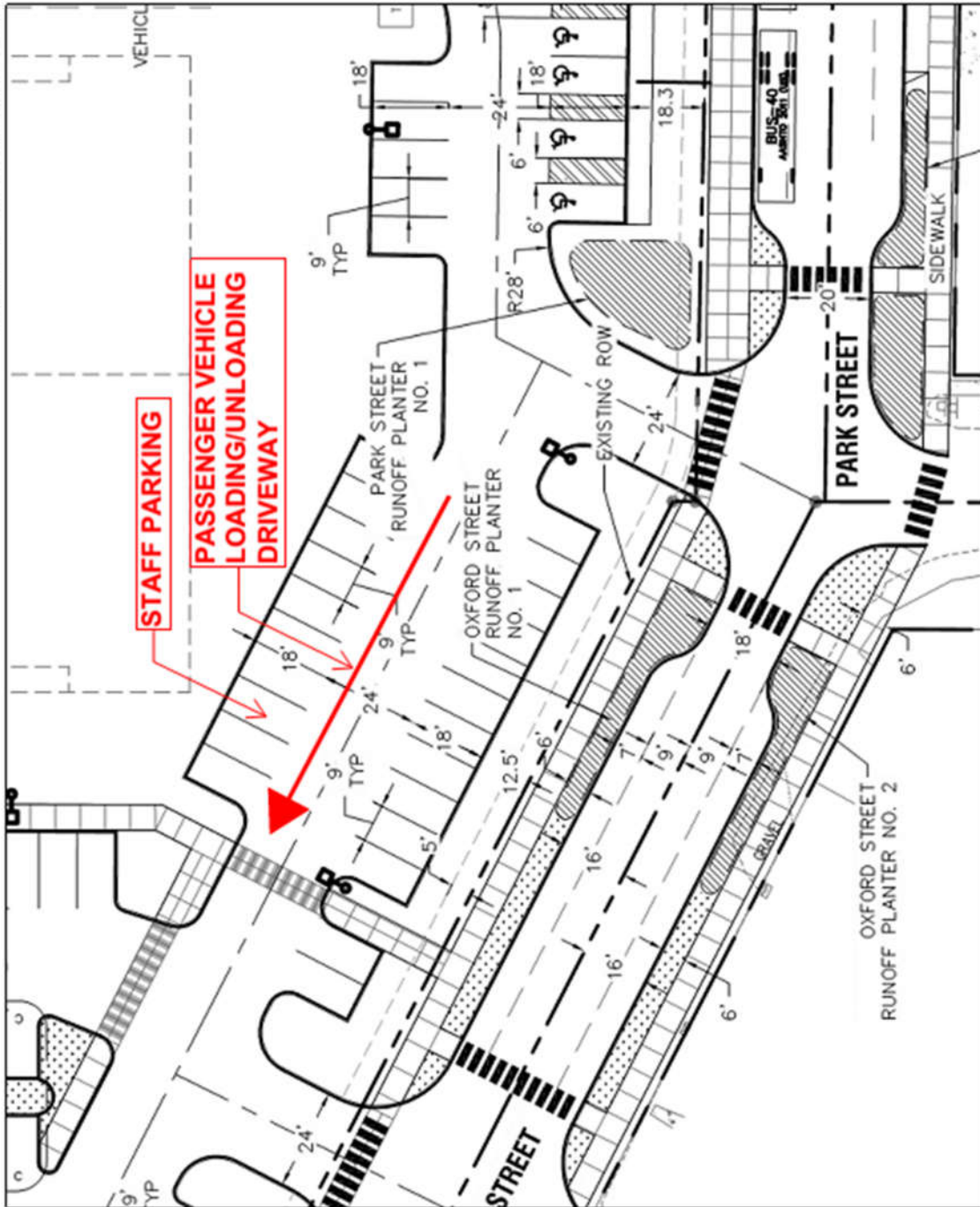

SUNSET REVISIONING - PASSENGER LOADING/UNLOADING EXHIBIT

MARCH 1, 2016

# PC-6 BITTNER STREET SANITARY SEWER PROPORTIONAL SHARE

- --- CITY RESPONSIBILITY
- --- SCHOOL DISTRICT RESPONSIBILITY

BITTNER STREET ROW PLAN

